

	Page
1. INTRODUCTION	1
2. SAFETY	1
2.1 GENERAL SAFETY	2
2.2 SAFETY TRAINING	3
2.3 SAFETY SIGNS	3
2.4 PREPARATION	4
2.5 MAINTENANCE SAFETY	4
2.6 OPERATING SAFETY	5
2.7 HYDRAULIC SAFETY	6
2.8 STORAGE SAFETY	6
2.9 TRANSPORT SAFETY	6
3. SAFETY SIGN LOCATIONS	7
4. OPERATION	8
4.1 TO THE NEW OPERATOR OR OWNER	8
4.2 MACHINE BREAK-IN	8
4.3 PRE-OPERATION CHECK LIST	8
4.4 DRIVELINE DIMENSION	9
4.5 MOUNTING AND UNHOOKING TRACTOR	10
4.6 CONTROLS	13
4.7 FIELD OPERATION	15
4.8 TRANSPORTING	21
5. SERVICE AND MAINTENANCE	22
5.1 FLUIDS AND LUBRICANTS	22
5.2 GREASING	22
5.3 SERVICING INTERVALS	22
5.4 DRIVELINE MAINTENANCE	23
6. SPECIFICATIONS	24
7. Exploded drawings and Part list for Brawn100S/Brawn160S/Brawn160R	24

1. INTRODUCTION

Congratulations on your choice of a Mateng 3 Point Hitch Wood Chipper to compliment your operation. This equipment has been designed and manufactured to meet the needs of a discerning timber or landscaping industry.

Safe, efficient and trouble free operation of your Mateng Wood Chipper requires that you and anyone else who will be using or maintaining the chipper, read and understand the Safety, Operation, Maintenance and Trouble Shooting information contained within the Operator's Manual.

This manual covers the Mateng 3 Point Hitch Wood Chipper BX42S, BX62S and BX62R Use the Table of Contents or Index as a guide to locate required information.

Keep this manual handy for frequent reference and to pass on to new operators or owners. Call your dealer or the Distributor if you need assistance, information or additional copies of the manuals.

OPERATOR ORIENTATION -The directions left, right, front and rear, as mentioned throughout this manual, are determined when sitting in the tractor driver's seat and facing in the direction of travel.

2. SAFETY

SAFETY ALERT SYMBOL

This Safety Alert symbol means
ATTENTION! BECOME ALERT!
YOUR SAFETY IS INVOLVED!



SIGNAL WORDS:

Note the use of the signal words **DANGER, WARNING** and **CAUTION** with the safety messages. The appropriate signal word for each message has been selected using the following guide-lines:

The Safety Alert symbol identifies important safety messages on Mateng 3 Point Hitch Wood Chipper and in the manual. When you see this symbol, be alert to the possibility of personal injury or death. Follow the instructions in the

DANGER- Indicates an imminently hazardous situation that, if not avoided, will result in death or serious injury. This signal word is to be limited to the most extreme situations typically for machine components which, for functional purposes, cannot be guarded.

WARNING- Indicates a potentially hazardous situation that, if not avoided, could result in death or serious injury, and includes hazards that are exposed when guards are removed. It may also be used to alert against unsafe practices.

CAUTION- Indicates a potentially hazardous situation that, if not avoided, may result in minor or moderate injury. It may also be used to alert against unsafe practices.

SAFETY

YOU are responsible for the SAFE operation and maintenance of your Mateng 3 Point Hitch Wood Chipper. **YOU** must ensure that you and anyone else who is going to use, maintain or work around the 3 Point Hitch Wood Chipper be familiar with the using and maintenance procedures and related **SAFETY** information contained in this manual. This manual will take you step-by-step through your working day and alerts you to all good safety practices that should be used while using the 3 Point Hitch Wood Chipper.

Remember, **YOU** are the key to safety. Good safety practices not only protect you but also the people around you. Make these practices a working part of your safety program. Be certain that **EVERYONE** using this equipment is familiar with the recommended using and maintenance procedures and follows all the safety precautions. Most accidents can be prevented. Do not risk injury or death by ignoring good safety practices.

-3 Point Hitch Wood Chipper owners must give operating instructions to operators or employees before allowing them to operate the machine, and at least annually thereafter.

-The most important safety device on this equipment is a SAFE operator. It is the operator's responsibility to read and understand ALL Safety and Operating instructions in the manual and to follow these. Most accidents can be avoided.

-A person who has not read and understood all using and safety instructions is not qualified to use the machine. An untrained operator exposes himself and bystanders to possible serious injury or death.

-Do not modify the equipment in any way. Unauthorized modification may impair the function and/or safety and could affect the life of the equipment.

-Think SAFETY! Work SAFELY!

2.1 GENERAL SAFETY

1. Read and understand the Operator's Manual and all safety signs before using, maintaining, adjusting or cleaning the 3 Point Hitch Wood Chipper.



2. Have a first-aid kit available for use should the need arise and know how to use it.



3. Have a fire extinguisher available for use should the need arise and know how to use it.



4. Do not allow riders.

5. Wear appropriate protective gear.
6. This list includes but is not limited to:

- A hard hat
- Protective shoes with slip resistant soles
- Heavy gloves
- Wet weather gear
- Hearing Protection
- Respirator or filter mask



7. Install and secure all guards before starting.

8. Wear suitable ear protection for prolonged exposure to excessive noise.

9. Turn machine off, stop and disable engine, remove ignition key and place in your pocket, set park brake and wait for all moving parts to stop before servicing, adjusting, repairing or unplugging.

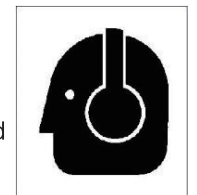

10. Clear the area of people, especially small children, before using the unit.

11. Review safety related items annually with all personnel who will operating or maintaining the 3 Point Hitch Wood Chipper.

2.2 SAFETY TRAINING

1. Safety is a primary concern in the design and manufacture of our products. Unfortunately, our efforts to provide safe equipment can be wiped out by a single careless act of an operator or bystander.

2. In addition to the design and configuration of equipment, hazard control and accident prevention are dependent upon the awareness, concern, prudence and proper training of personnel involved in the operation, transport, maintenance and storage of this equipment.

3. It has been said, "The best safety feature is an informed, careful operator." We ask you to be that kind of an operator. It is the operator's responsibility to read and understand the operator's manual



4. Working with unfamiliar equipment can lead to careless injuries. Read this manual before assembly or using, to acquaint yourself with the machine. If this machine is used by any person other than yourself, or is loaned or rented.

5. Know your controls and how to stop tractor and machine quickly in an emergency. Read this manual and the one provided with tractor.

6. Train all new personnel and review instructions frequently with existing workers. Be certain only a properly trained and physically able person will use the machinery. A person who has not read and understood all using and safety instructions is not qualified to use the machine. An untrained operator exposes himself and bystanders to possible serious injury or death. If the elderly are assisting with the work, their physical limitations need to be recognized and accommodated.

2.3 SAFETY SIGNS

1. Keep safety signs clean and legible at all times.
2. Replace safety signs that are missing or have become illegible.
3. Replaced parts that displayed a safety sign should also display the current sign.
4. Safety signs displayed in Section 3 each have a part number in the lower right hand corner. Use this part number when ordering replacement parts.
5. Safety signs are available from your authorized Distributor or Dealer Parts Department or the factory.

How to Install Safety Signs:

Be sure that the installation area is clean and dry.

Be sure temperature is above 50°F (10°C).

Determine exact position before you remove the backing paper.

Remove the smallest portion of the split backing paper.

Align the sign over the specified area and carefully press the small portion with the exposed sticky backing in place.

Slowly peel back the remaining paper and carefully smooth the remaining portion of the sign in place.

Small air pockets can be pierced with a pin and smoothed out using the piece of sign backing paper.

2.4 PREPARATION

1. Never use the machine until you have read and completely understand this manual, the tractor Operator's Manual and each of the Safety Messages found on the safety signs on the tractor and machine.

2. Personal protection equipment including hard hat, safety glasses, safety shoes, and gloves



are recommended during assembly, installation, operation, adjustment, maintaining, repairing, removal, cleaning, or moving the unit. Do not allow long hair, loose fitting clothing or jewellery to be around equipment.

3. **PROLONGED EXPOSURE TO LOUD NOISE MAY CAUSE PERMANENT HEARING LOSS!**

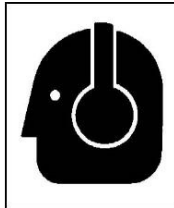

Power equipment with or without equipment attached can often be noisy enough to cause permanent, partial hearing loss. We recommend that you wear hearing protection on a full-time basis if the noise in the Operator's position exceeds 80db. Noise over 85db on a long-term basis can cause severe hearing loss. Noise over 90db adjacent to the Operator over a long-term basis may cause permanent, total hearing loss. **NOTE:** Hearing loss from loud noise (from tractors, chain saws, radios, and other such sources close to the ear) is cumulative over a lifetime without hope of natural recovery.

4. Clear working area of stones, branches or hidden obstacles that might be hooked or snagged, causing injury or damage.
5. Use only in daylight or good artificial light.
6. Be sure machine is properly mounted, adjusted and in good operating condition.
7. Ensure that all safety shielding and safety signs are properly installed and in good condition

2.5 MAINTENANCE SAFETY

1. Good maintenance is your responsibility. Poor maintenance is an invitation to trouble.
2. Follow good shop practices.

- Keep service area clean and dry.
- Be sure electrical outlets and tools are properly grounded.
- Use adequate light for the job at hand.



3. Make sure there is plenty of ventilation. Never operate the engine of the towing vehicle in a closed building. The exhaust fumes may cause asphyxiation.
4. Before working on this machine, shut off the engine, set the brake, and turn fuel valve off.
5. Never work under equipment unless it is blocked securely.
6. Always use personal protection devices such as eye, hand and hearing protectors, when performing any service or maintenance work. Use heavy or leather gloves when handling blades.
- 3 Where replacement parts are necessary for periodic maintenance and servicing, genuine factory replacement parts must be used to restore your equipment to original specifications. The manufacturer will not be responsible for injuries or damages caused by use of unapproved parts and/or accessories.
7. A fire extinguisher and first aid kit should be kept readily accessible while performing maintenance on this equipment.
8. Periodically tighten all bolts, nuts and screws and check that all electrical and fuel connections are properly secured to ensure unit is in a safe condition.
10. When completing a maintenance or service function, make sure all safety shields and devices are installed before placing unit in service.

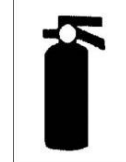

2.6 OPERATING SAFETY

1. Please remember it is important that you read and heed the safety signs on the 3 Point Hitch Wood Chipper. Clean or replace all safety signs if they cannot be clearly read and understood. They are there for your safety, as well as the safety of others. The safe use of this machine is strictly up to you, the operator.
2. All things with moving parts are potentially hazardous. There is no substitute for a cautious, safe-minded operator who recognizes potential hazards and follows reasonable safety practices. The manufacturer has designed this 3 Point Hitch Wood Chipper to be used with all its safety equipment properly attached, to minimize the chance of accidents. Study this manual to make sure you have all safety equipment attached.
3. Close and secure rotor cover before operating.
4. Close and secure all guards, deflectors and shields before starting and operating.
5. Read and understand operator's manual before starting. Review safety instructions annually.
6. Personal protection equipment including hearing protection, hard hat, safety glasses, safety shoes, and gloves are recommended during assembly, installation, operation, adjustment, maintaining, repairing, removal, or moving. Do not allow long hair, loose-fitting clothing, or jewellery to be around moving parts.
7. Keep hydraulic lines and fittings tight, in good condition and free of leaks.
8. Never place any part of your body where it would be in danger if movement should occur during assembly, installation, operation, maintenance, repairing, unplugging or moving.
9. Turn machine off, stop and disable engine, remove ignition key and place in your pocket, set park brake and wait for all moving parts to stop before servicing, adjusting, repairing or unplugging.
10. Do not run machine inside a closed building to prevent asphyxiation from engine exhaust.
11. Use care when feeding material into chipper. Do not send metal, bottles, cans, rocks, glass or other foreign material into wood chipper. If foreign material enters chipper, stop machine, turn engine off and place ignition key in your pocket and wait for all moving parts to stop before removing material and/or unplugging.

Inspect machine for damaged or loose parts before resuming work.

12. Never use alcoholic beverages or drugs which can hinder alertness or coordination while operating this equipment. Consult your doctor about operating this machine while taking prescription medications.
13. Do not allow riders on this machine at any time. There is no safe place for any riders.
14. Never allow children or unauthorized people to operate or be around this machine.
15. Do not reach into rotor or feed hopper openings when the engine is running. Install and secure access covers before starting engine.
16. Keep the working area clean and free of debris to prevent tripping. Operate only on level ground.
17. Do not point discharge at people, animals or buildings. Rotor can expel wood chips fast enough to cause injury.
18. Do not move or transport chipper when the rotor is turning.
19. Do not exceed a safe travel speed when transporting.

2.7 HYDRAULIC SAFETY

1. Make sure that all the components in the hydraulic system are kept in good condition and are clean.
2. Before applying pressure to the system, make sure all components are tight, and that lines, hoses and couplings are not damaged.
3. Do not attempt any makeshift repairs to the hydraulic lines, fittings or hoses by using tapes, clamps or cements. The hydraulic system operates under extremely high pressure. Such repairs will fail suddenly and create a hazardous and unsafe condition.
4. Wear proper hand and eye protection when searching for a high pressure hydraulic leak. Use a piece of wood or cardboard as a backstop instead of hands to isolate and identify a leak.
5. If injured by a concentrated high-pressure stream of hydraulic fluid, seek medical attention immediately. Serious infection or toxic reaction can develop from hydraulic fluid piercing the skin surface.
6. Relieve pressure on hydraulic system before maintaining or working on system.

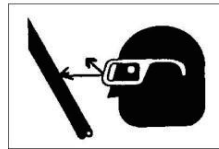

2.8 STORAGE SAFETY

1. Store the unit in an area away from human activity.
2. Do not children to play on or around the stored machine.
3. Store the unit in a dry, level area. Support the frame with planks if required.

2.9 TRANSPORT SAFETY

1. Comply with state and local laws governing safety and transporting of machinery on public roads.
2. Check that all the lights, reflectors and other lighting requirements are installed and in good working condition.
3. Do not exceed a safe travel speed. Slow down for rough terrain and cornering.
4. Fold up and secure feed hopper before moving or transporting.
5. Be sure the machine is hitched positively to the tractor and a retainer is used through the mounting pins.
6. Do not drink and drive.
7. Be a safe and courteous driver. Always yield to oncoming traffic in all situations, including narrow bridges, intersections, etc. Watch for traffic when operating near or crossing roadways.
8. Never allow riders on the machine.

3 SAFETY SIGN :

<div data-bbox="305 268 743 1060"> <p>CAUTION</p> <ul style="list-style-type: none"> • Read and understand operator's manual before starting. Review safety instructions annually. • Turn machine off, stop and disable engine, remove ignition key and place in your pocket, set park brake and wait for all moving parts to stop before adjusting, servicing, maintaining, repairing or unplugging. • Keep the working area clean and free of debris to prevent slipping or tripping. Operate only on level ground. • Close and secure rotor cover before operating. • Close and secure all guards, deflectors and shields before starting and operating. • Keep hydraulic lines and fittings tight, in good condition and free of leaks. • Keep hands, feet, hair and clothing away from moving parts. Never wear loose clothing around machinery. • Keep driveline universal joint angles equal and small as possible. • Do not point discharge at people, animals or buildings. Rotor can expel wood chips fast enough to cause injury. • Do not allow children, animals or unauthorized people into working area. • Do not run machine inside a closed building to prevent asphyxiation from engine exhaust. • Use care when feeding material into chipper. Do not send metal, bottles, cans, rocks, glass or other foreign material into wood chipper. If foreign material enters chipper, stop the machine, turn engine off and place ignition key in your pocket and wait for all moving parts to stop before removing material and/or unplugging. Inspect machine for damaged or loose parts before returning to work. • Always wear P.P.E. (Personal Protective Equipment) such as safety goggles and heavy gloves whenever operating machine. • Do not place hands or any body parts into feed hopper during operation. • Do not move or transport chipper when the rotor is turning. • Do not exceed a safe travel speed when transporting. Z94006 </div>	<div data-bbox="885 262 1218 640"> <p>DANGER</p> <p>THROWN OBJECT HAZARD</p> <p>To prevent serious injury or death from thrown objects:</p> <ul style="list-style-type: none"> • Turn machine off, stop and disable engine, remove ignition key and place in your pocket, set park brake and wait for all moving parts to stop before adjusting, servicing, maintaining, repairing or unplugging. • Do not direct discharge duct towards people, animals or property. Always wear appropriate safety gear. Keep hands and feet out of discharge openings. • Keep others away. <p>Z94008</p> </div>
<div data-bbox="305 1102 743 1438"> <p>DANGER</p> <p>ROTATING CUTTING BLADES</p> <p>Keep hands and feet out of inlet and discharge openings while machine is operating to avoid serious personal injury. Stop engine, remove spark plug wire and allow machine to come to a complete stop before clearing obstructions or making adjustments.</p> <p>Z94007</p> </div>	<div data-bbox="876 1102 1226 1438"> <p>WARNING</p> <p>HIGH PRESSURE FLUID HAZARD</p> <p>To prevent serious injury or death from high-pressure fluid:</p> <ul style="list-style-type: none"> • Relieve pressure on system before repairing or adjusting. • Wear proper hand and eye protection when searching for leaks. Use wood or cardboard instead of hands. • Keep all components in good repair. <p>Z94005</p> </div>
<div data-bbox="324 1480 706 1848"> <p>REVERSE NEUTRAL FEED</p> <p>Z94014</p> </div>	<div data-bbox="868 1480 1250 1848"> <p>FEED NEUTRAL REVERSE</p> <p>Z94015</p> </div>

4. OPERATION

4.1 TO THE NEW OPERATOR OR OWNER

The Mateng 3 Point Hitch Wood Chippers are designed to chip or chop scrap lumber, small trees, brush, limbs and other wood debris. The chipped material is fine enough to be composted or used in a variety of ways.

It is the responsibility of the owner or operator to read this manual and to train all other operators before they start working with the machine. Follow all safety instructions exactly. Safety is everyone's business. By following recommended procedures, a safe working environment is provided for the operator, bystanders and the area around the worksite. Untrained operators are not qualified to use the machine. Follow all safety instructions exactly. Safety is everyone's business. By following recommended procedures, a safe working environment is provided for the operator, bystanders and the area around the worksite. Untrained operators are not qualified to operate the machine.

Many features incorporated into this machine are the result of suggestions made by customers like you. Read this manual carefully to learn how to use the chipper safely and how to set it to provide maximum field efficiency. By following the using instructions in conjunction with a good maintenance program, your 3 Point Hitch Wood Chipper will provide many years of trouble-free service.

4.2 MACHINE BREAK-IN

Although there are no operational restrictions on the Wood Chipper when used for the first time, it is recommended that the following mechanical items be checked:

A. After operating for 1 hour:

1. Torque all fasteners and hardware.
2. Check condition of rotor bearings.
3. Check the condition and clearance of the twig-breaker, rotor and stationary blades. Adjust or replace as required.
4. Check for entangled material. Remove all entangled material before resuming work.
5. Lubricate all grease fittings.

B. After operating for 10 hours:

1. Repeat steps 1 through 5 listed above. (Section A)
2. Go to the normal servicing and maintenance schedule as defined in the Maintenance Section.

4.3 PRE-OPERATION CHECKLIST

Efficient and safe operation of the Wallenstein 3 Point Hitch Wood Chipper requires that each operator reads and understands the using procedures and all related safety precautions outlined in this section. A pre-operation checklist is provided for the operator. It is important for both the personal safety and maintaining good mechanical condition that this checklist is followed.

Before operating the Wood Chipper and each time thereafter, the following areas should be checked off:

1. Lubricate the machine per the schedule outline in the Maintenance Section.
2. Check the rotor, blades and twig-breaker. Remove any twine, wire or other material that has become entangled.
3. Check the condition and clearance of the twig-breaker, rotor and stationary blades. Adjust or replace as required.
4. Check that all bearings turn freely. Replace any that are rough or seized.
5. Make sure that all guards and shields are in place, secured and functioning as designed.
6. Check the condition of the curtain in the feed hopper. It must be in good condition to prevent chips from flying out

4.4 DRIVELINE DIMENSION

A PTO drive line is supplied with the machine. To accompany the variety of 3 point hitch geometry available today, the drive line can be too long for most machines or too short for others. It is very important that the drive line be free to telescope but not to bottom out when going through its working range. If the drive line bottoms out, the bearings on both the machine and tractor PTO shaft will be overloaded and fail in a short time.

1. To determine the proper length of the drive line, follow this procedure:

- Clear the area of bystanders, especially small children.
- Attach the chipper to the tractor but do not attach the drive line.
- Raise the machine until the input shaft is level with the tractor PTO shaft.
- Measure the dimension between the locking grooves on the tractor PTO shaft and the machine input shaft.
- Measure the same dimensions on the compressed drive line.
- If the compressed drive line dimension exceeds the machine dimension, the drive line will have to be cut.

2. When cutting the drive line, follow this procedure:

a. Subtract the machine dimension (A) from the uncut drive line dimension (B) or (B-A). This dimension determines how much too long the drive line is.

b. Add another inch (25 mm) to the dimension to be sure it doesn't bottom out, to determine (C) the cut off dimension.

c. Use a hacksaw to cut dimension (C) from both ends. Cut both the plastic tubes and the metal cores.

d. Use a file to remove the burrs from the edges that were cut.

e. Assemble the 2 ends of the shaft.

f. Make sure the shaft can telescope freely. If it does not, separate the 2 parts and inspect for burrs or cuttings on the shaft ends. Be sure it telescopes freely before installing.

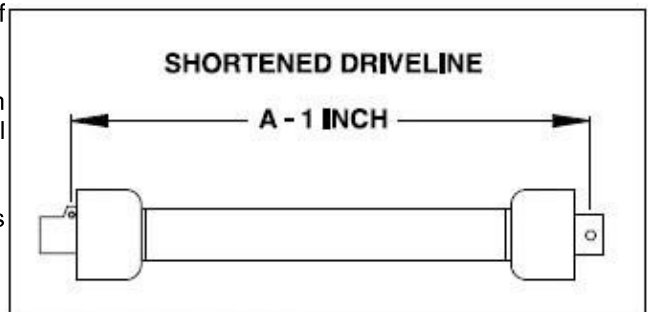
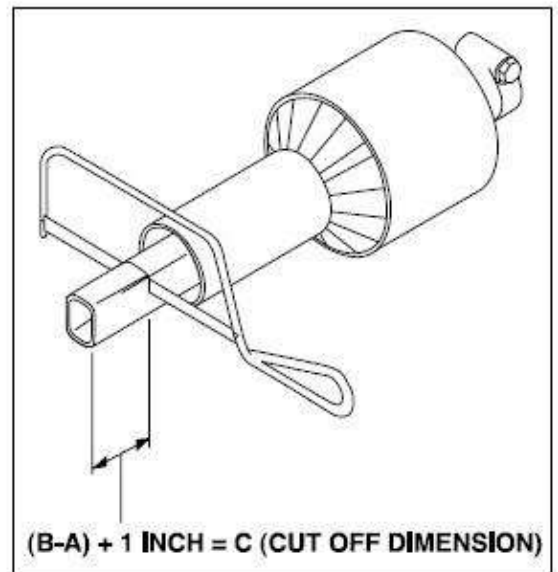
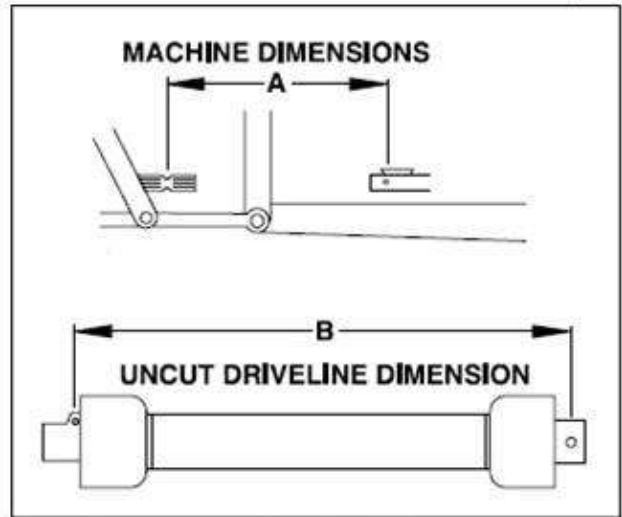

4.5 MOUNTING AND UNHOOKING TRACTOR

When attaching chipper to a tractor, follow this procedure:

1. Clear the area of bystanders, especially small children.
2. Make sure there is enough room and clearance to safely back up to the chipper.
3. Place the tractor arms in their full sway position.
4. Back up slowly and align the lower link arms to the pins on the machine.
5. Mounting without a Quick Hitch

- a. Align the left lower link with the left chipper pin.

IMPORTANT

It may be necessary to add weight to the lower lift arms to bring them to the required height.

- b. Insert the left pin through the ball and install the retainer.
- c. Align the right arm to the pin by turning the jackscrew on the arm.
- d. Insert the right pin through the ball and install the retainer. Return the jackscrew to its starting position.
- e. Remove the top pin and install the top link. Use the turnbuckle to align the top link. Insert the pins and install the retainers. Return the turnbuckle to its original length and lock.



Aligned



Pinned



TOP LINK

6. Mounting with a Quick Hitch.
 - a. Align the claws on the Quick Hitch slightly below the mounting pins on the chipper.

IMPORTANT

It may be necessary to add weight to the lower lift arms to bring them to the required height.

- b. Back up until the pins are above the claws.
 - c. Use the turnbuckle on the top link to adjust the position of the top claw.
 - d. Raise the 3 point hitch until the pins seat in the claws.
 - e. Be sure the retainers are released to hold the pins in the claws.
7. Set the 3 point hitch in the non-sway position (see tractor manual for details).
8. Install the PTO drive line:

NOTE

Be sure the telescoping portion of the shaft is greased and free of dirt.

NOTE

The drive line should already have been cut to the required length.

- a. Slide the collar back on the yoke, align the splines and slide the yoke on the tractor
 - b. Release the collar and make sure the locking pin clicks into position.



PTO SHAFT

9. Connect the hydraulics:

- a. Use a clean rag or paper towel to clean the dirt from couplers on the hose ends and the tractor.
- b. Connect the hoses to the tractor couplers. Be sure the couplers are securely seated.
- c. Route and secure the hoses along the hitch with clips, tape or plastic ties to prevent binding and pinching. Be sure to provide slack for turning.

NOTE

Always connect to the hydraulic circuit with a decent.



HYDRAULICS

10. Slowly raise the machine through its working range to make sure the telescoping portion of the PTO shaft doesn't bottom out.

Level the machine front and rear, and side to side using the jackscrew on the right arm and the turnbuckle on the top link.

11. The chipper should always be level on the ground in its working position.

12. To unhook from the tractor, reverse the above procedure. Always park the machine in a dry, level area. If vandalism is a problem, remove the PTO drive line and store in a secure place.

 WARNING	
	
HIGH PRESSURE FLUID HAZARD To prevent serious injury or death from high-pressure fluid:	
<ul style="list-style-type: none">• Relieve pressure on system before repairing or adjusting.• Wear proper hand and eye protection when searching for leaks. Use wood or cardboard instead of hands.• Keep all components in good repair.	



4.6 CONTROLS

All controls are conveniently positioned next to where the operator would stand when feeding the machine to provide easy operation. Review this section to familiarize yourself with the location and function of each control before starting.

1. Hydraulic Feed Control Lever:

Hydraulic units only: This lever is positioned to extend around the feed hopper and provides access from all sides. The lever is attached to the directional flow valve and controls feeding, neutral and reverse functions. To operate: pull the control all the way out to engage the feeding system. Push in slightly to the first detent to stop the feeding system. Push the control all the way in to reverse the feeding system.

IMPORTANT

Check the function of the control lever when attaching the hydraulic lines to the tractor. The hopper must feed in when the lever is moved out. **If it does not, reverse the hoses.** The control lever must function like the drawing on each side of the hopper or the hoses must be reversed.

NOTE

Use the flow control valve next to the directional control valve to set the feeding speed. (see next page)

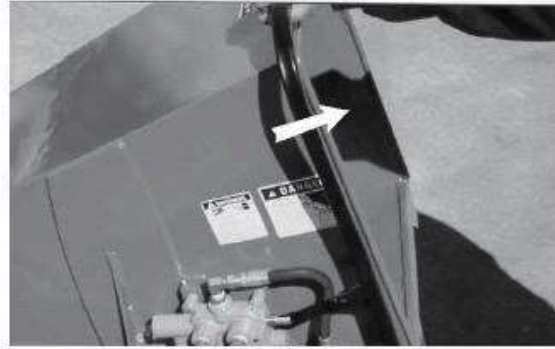

Feeding



Neutral/Stop



Reversing

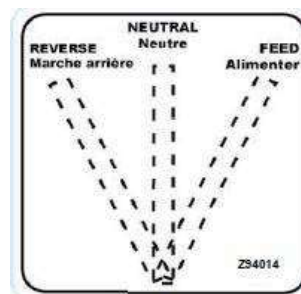

Left Side

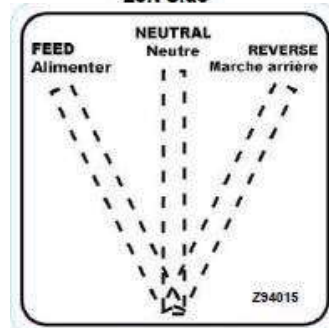

Right Side

2. Flow Control Valve:

Hydraulic units only:

The hydraulic feed circuit is equipped with a manually-set flow control so the operator can adjust the feeding speed appropriate for the operating conditions. A scale on the face of the valve is numbered from 0 to 10 (0 to 100%).

To adjust the feed:

1. Loosen the lock and
2. Move the pointer arm to the desired position.
3. Tighten the lock bolt.

Note: Adjust in small increments as a small change can result in a large change to feeding speed.



3. Deflector Position:

Each discharge hood is equipped with a deflector on the end to place the chips exactly where desired. There are 2 types available, depending on your model:

- a. **Manual Clamp:** The deflector is held in place by clamping bolts on each side. Loosen the clamps, move the deflector and tighten the clamps. Position as desired.
- b. **Spring-Loaded:** The deflector is spring-loaded up and held in place by a chain. Release the chain from its anchor bracket and move the deflector to its desired position. Secure chain in its anchor bracket.



Manual Clamp

4. PTO Control:

If you are not familiar with the location of the PTO control on your tractor, review your tractor's Operator's Manual. Always engage the PTO control slowly when the engine is running at low idle RPM. Disengage the PTO control slowly at low RPM to allow the machine to slow and stop before engaging the PTO brake. Remember the PTO drives the rotor. When the PTO is engaged the rotor will also start to turn.



Spring- Loaded

4.7 FIELD OPERATION



OPERATING SAFETY

- Please remember it is important that you read the operator's manual and heed the safety signs on the 3 Point Hitch Wood Chipper. They are there for your safety, as well as the safety of others. The safe use of this machine is strictly up to you, the operator.
- Personal protection equipment including hearing protection, hard hat, safety glasses, safety shoes, and gloves are recommended during assembly, installation, operation, adjustment, maintaining, repairing, or plugging. Do not allow long hair, loose-fitting clothing, or jewellery to be around moving parts.
- Turn machine off, stop and disable engine, remove ignition key and place in your pocket, set park brake and wait for all moving parts to stop before servicing, adjusting, repairing or unplugging.
- Do not run machine inside a closed building to prevent asphyxiation from engine exhaust.
- Use care when feeding material into chipper. Do not send metal, bottles, cans, rocks, glass or other foreign material into wood chipper. If foreign material enters chipper, stop machine, turn engine off and place ignition key in your pocket and wait for all moving parts to stop before removing material and/or unplugging. Inspect machine for damaged or loose parts before resuming work.
- Never use alcoholic beverages or drugs which can hinder alertness or coordination while operating this equipment. Consult your doctor about operating this machine while taking prescription medications.
- Do not allow riders on this machine at any time. There is no safe place for any riders.
- Never allow children or unauthorized people to operate or be around this machine.
- Do not reach into rotor or feed hopper openings when the engine is running. Install and secure access covers before starting engine.
- Do not move or transport chipper when the rotor is turning.
- Do not exceed a safe travel speed when transporting.
- Keep hydraulic lines and fittings tight, in good condition and free of leaks.
- Keep the working area clean and free of debris to prevent tripping. Operate only on level ground.
- Do not point discharge at people, animals or buildings. Rotor can expel wood chips fast enough to cause injury.

Although the 3 Point Hitch Wood Chipper is easy to use, each operator should review this section to familiarize himself with the detailed safety and operating procedures. When using this machine, follow this procedure:

1. Clear the area of bystanders, especially small children.
2. Review and follow the Pre-Operation Checklist
3. Attach the machine to the tractor
4. Drive to the work area and position at the worksite.
5. Set park brake.
6. Stop engine.
7. Remove ignition key and place in your pocket.
8. Move the feed hopper down into its working configuration and secure with the anchor nuts.
9. Turn discharge hood to its working position.

1. Starting the Machine:

- a. Start the tractor engine.
- b. Move the throttle to its low idle position.
- c. With the engine at low idle, slowly engage the PTO control.
- d. Slowly increase the engine speed until the PTO is at rated speed.
- e. With the manual feeding model, start feeding material into the hopper.
- f. With the hydraulic feeding model:
Place the tractor hydraulic lever into its detent position.
Move the control lever into the feed position.
Start feeding material into the hopper.

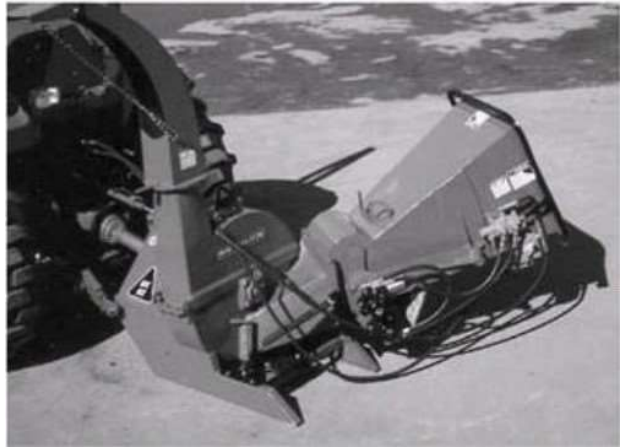

2. Stopping:

- a. Stop feeding material into the hopper.
- b. Place the hydraulic feed control in off/ neutral.
- c. Slow engine RPM.
- d. Place hydraulic lever in its OFF position.
- e. Disengage PTO.
- f. Stop engine, remove ignition key and place in your pocket and wait for all moving parts to stop.

3. Emergency Stopping:

Stop tractor engine if an emergency occurs. Correct emergency situation before starting engine and resuming work.

4. Feeding:

a. Self- Feed Hopper:

- Slowly slide the wooden material into the feed hopper and move it into the rotor.
- Do not push the material with a lot of force into the rotor.
- Do not push the material too fast into the rotor. Stop and slow down if the engine starts to slow down.
- Do not reach into the feed hopper further than the curtain to be sure not to contact the blades on the rotor.
- Use a stick or branch to push any piece of material into the rotor that does not move on its own and stops in the hopper. Do not take a chance with getting your hand caught in the rotor.

b. Hydraulic Feed Hopper:

- Slowly slide the wooden material into the feed hopper until the roller grabs the material and move it into the rotor.
- Use the flow divider on the side of the feed hopper to set the feeding speed.
- Do not reach into the feed hopper further than the curtain to be sure not to contact the feed roller or the blades on the rotor.
- Use a stick or branch to push any piece of material into the feed roller that does not move on its own and stops in the hopper. Do not take a chance with getting your hand caught in the feed roller.

Always wear personal protective equipment (PPE) whenever operating the machine. This includes but is not limited to protective shoes with slip resistant soles, protective goggles or face shield, heavy gloves, hearing protection and protective clothing.

Do not place metal, bottles, cans, rocks, glass or other solid material into the wood chipper. If something like this gets into the machine, stop the machine immediately for a detailed inspection. Stop engine, remove ignition key and place in your pocket and wait for all moving parts to stop before inspecting or unplugging. Inspect machine for damaged or loosened parts before resuming work.

5. Blades:

There are 2 types of blades used on the Wood Chipper. They work together to cut, shear and shred the wood as it moves through the machine.

a. Rotor blades:

The rotor is equipped with 4 blades placed at 90° to each other to keep the rotor in balance. If one needs to be changed, the one opposite should be changed.

b. Stationary blade:

Each machine is equipped with a stationary blade that acts as a stop for the moving rotor blades.

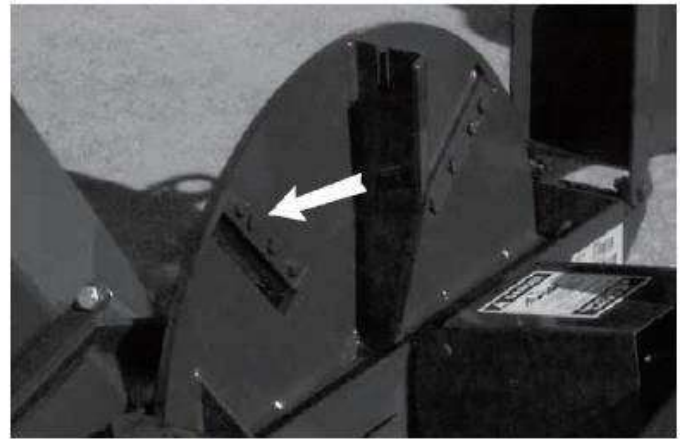

General location of rotor blades on BX model chippers



6. Sharpening Blades:

The rotor and stationary blades need to be sharp for the chipper to perform as expected. It is recommended that the rotor blades be removed from the rotor when sharpening. Always sharpen the blades at a 45° angle to provide the best cutting effect as it meets the stationary blade. Be sure to tighten the blade mounting bolts to their specified torque when re-installing the blades to the rotor. The stationary blade is designed with 4 sharp corners that can be utilized. When the corner facing the rotor blade rounds over, remove the blade and re-install with a different corner facing the rotor blade. Use the stationary blade to set the clearance to the rotor blade when re-installing. Be sure to tighten mounting bolts to their specified torque.

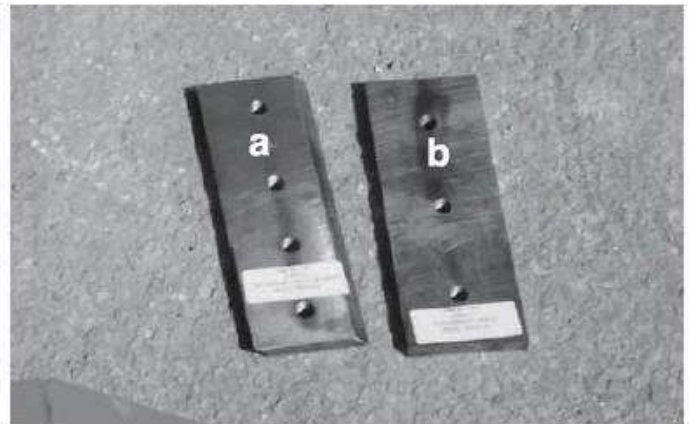

Example of Rotor (a) and Stationary (b) blades

7. Clearance: It is recommended that the clearance between the rotor and stationary blades be set and maintained at 1/32 to 1/16 inch to obtain the best performance. Use the stationary blade mounting bolts to set the clearance as required.

8. Twig Breaker:

Each machine is equipped with a twig breaker to break up twigs or other long material as it moves through the rotor compartment. Open the rotor cover and check the condition of the breaker on a weekly basis. Also check for any entangled material when the rotor cover is opened. Remove this material prior to closing the cover and resuming work.

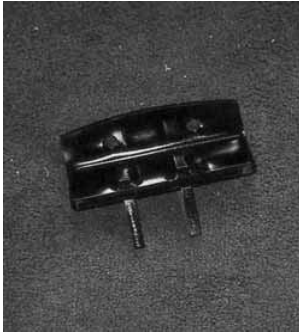

**Twig breaker:
dual prong
shown, some
models will have
single tooth**

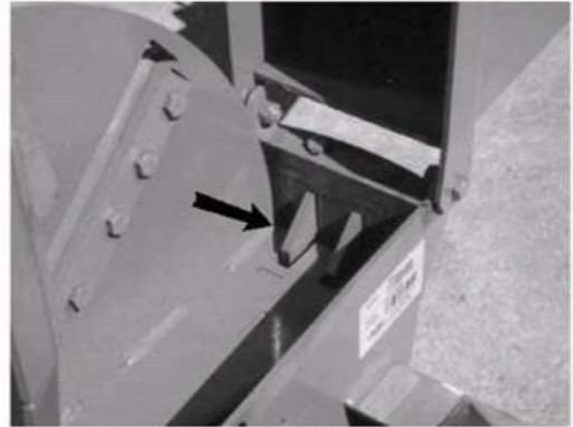

View of twig breaker teeth inside rotor compartment

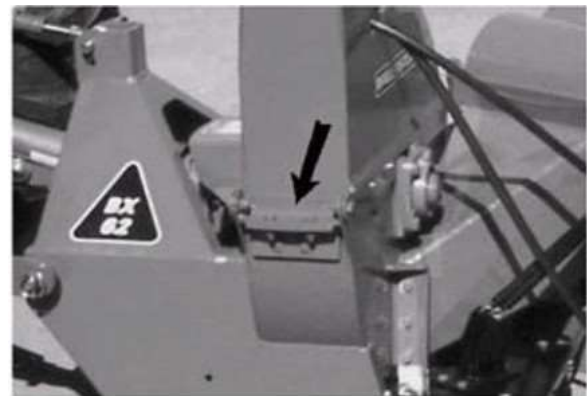

Exterior mounting of twig breaker

9. Unplugging:

Although the machine is designed to handle a wide variety of material without any problem, it may occasionally plug up. When the machine plugs, follow this procedure to unplug:

1. Clear the area of bystanders, especially small children.
2. Reverse the hydraulic feed hopper to work lose any plugged material.
3. Next stop the engine, remove the ignition key and place it in your pocket and wait for all moving parts to stop before unplugging.
4. Pull the material out of the **feed hopper**. Be sure all the material is out and nothing is jammed or wedged between the input opening and the rotor.
5. Pull the material out of the discharge hood. Use a stick to poke loose any material jammed into the **discharge hood**. Do not allow anything to remain in this area.

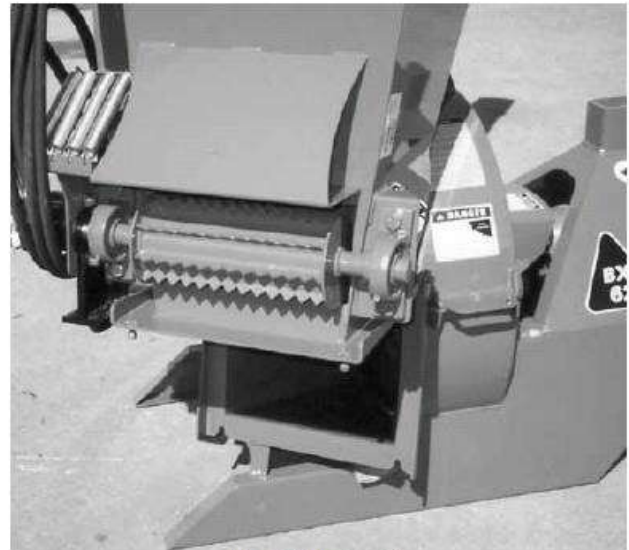

Feed Hopper

10. Severe plug:

1. Ensure the engine is off and you have pocked the key to prevent unintentional startup.
2. Loosen the feed hopper anchor nuts and raise the feed hopper. Remove material from inside the rotor compartment.
3. Clean out the discharge area/rotor.
4. Open the **rotor cover** and clean out the housing. Be sure to turn the rotor by hand to be sure there is nothing jammed between the rotor and stationary blades.
5. Close, install and fold down all components opened to unplug. Tighten fasteners to their specified torque.
6. Check that everyone is clear of machine before restarting engine.
7. Start the engine, engage the PTO and resume working.

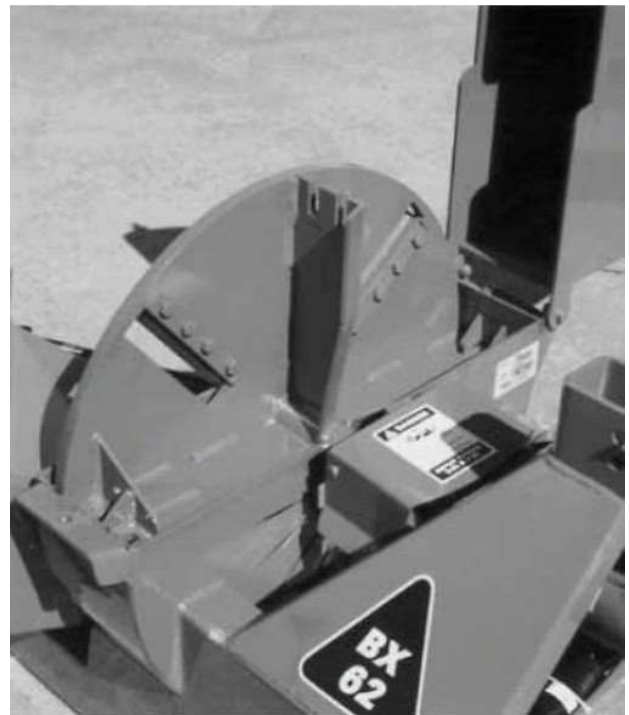

Rotor Cover

11. Cleaning:

Clean the machine frequently to prevent a buildup of dust, chips and trash on the frame. A clean machine reduces the chance of rusting.

12. Curtains:

Each feed hopper is designed with an internal rubber/belting curtain to prevent chips and debris from coming out of the hopper when working. Check the condition of the curtain each day prior to starting. Replace the curtain if torn, damaged or missing to minimize the chance of material coming out of the feed hopper.

13. Personal Protective Equipment (PPE):

Each person must wear appropriate personal protective equipment whenever operating the chipper or working in the vicinity. This equipment is designed to prevent injury to any personnel in the area. This list includes but is not limited to:

1. Safety shoes with slip resistant soles.
2. Safety goggles or face shield.
3. Hearing protection.
4. Heavy or leather gloves.

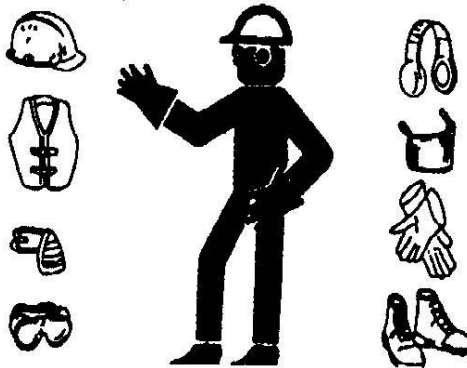

14. Operating Hints:

- A. Keep the working area clean and free of debris to prevent slipping or tripping. Operate only on level ground.
- B. Do not place hands or any body parts into the feed hopper during operation. Use a stick or branch to push material into the rotor when it goes past the curtain in the feed hopper.
- C. Do not point discharge at people, animals or buildings. Rotor can expel wood chips fast enough to cause injury.
- D. Use care when feeding material into the chipper. Do not send metal, bottles, cans, rocks, glass or other foreign material into the wood chipper. If foreign material enters chipper, stop machine, turn engine off and place ignition key in your pocket and wait for all moving parts to stop before removing material and/or unplugging. Inspect machine for damaged or loose parts before resuming work.

4.8 TRANSPORTING

When transporting the machine, review and follow these instructions:

1. Clear the area of bystanders, especially small children.
2. Check that all the lights and reflectors required by the highway authorities are in place, clean and working.
3. Insure that the machine is securely attached to the tractor with a retainer through the mounting pins.
4. Do not allow riders.
5. Never exceed a safe travel speed. Slow down when encountering rough road conditions and cornering.
6. Do not drink and drive.
7. Raise and secure the feed hopper before transporting.
8. Turn the discharge hood and point toward the rotor to reduce the width of the machine.

5 SERVIC AND MAINTENANCE

By following a careful service and maintenance program for your machine, you will enjoy many years or trouble-free operation.

5.1 FLUIDS AND LUBRICANTS

1. **Grease:** Use multipurpose high temperature grease with extreme pressure (EP) performance. Also acceptable is multipurpose lithium base grease.
2. **Storing Lubricants:** Your machine can operate at top efficiency only if clean lubricants are used. Use clean containers to handle all lubricants. Store them in an area protected from dust, moisture and other contaminants.

5.2 GREASING

Use the Maintenance Checklist provided to keep a record of all scheduled maintenance.

1. Use a hand-held grease gun for all greasing.
2. Wipe grease fitting with a clean cloth before greasing, to avoid injecting dirt and grit.
3. Replace and repair broken fittings immediately.
4. If fittings will not take grease, remove and clean thoroughly. Also clean lubricant passageway. Replace fittings if necessary.

5.3 SERVICING INTERVALS

See service record and service illustration for service interval information. The period recommended is based on normal operating conditions. Severe or unusual conditions may require more frequent lubrication or oil changes.

IMPORTANT Do Not over grease.

5.4 DRIVELINE MAINTENANCE

The PTO drive line is designed to telescope to allow for dimensional changes as the machine goes through its operational range. A tubular guard encloses the driving components and is designed to turn relative to the driving components. The drive line should telescope easily and the guard turn freely on the shaft at all times. Annual disassembly, cleaning and lubrication is recommended to insure that all components function as intended. To maintain the drive line, follow this procedure:

1. Remove the drive line from the machine.
2. Pull drive line apart.
3. Use a screwdriver to turn lock studs on each end. There are 2 studs per guard.
4. Pull the shaft out of the plastic tubular guard.
5. Use a solvent to clean the male and female portions of the telescoping ends.
6. Apply a light coat of grease to each end.
7. Use a solvent to wash the grooves on each end where the studs are located. Clean each end also.
8. Apply a light coat of grease to each groove.
9. Insert the shaft into its respective guard and align the studs with the holes.
10. Insert the studs through the holes and seat in the groove.
11. Turn each stud to secure guard to shaft.
12. Check that each guard turns freely on the shaft.
13. Assemble the drive line.
14. Check that the drive line telescopes easily.
15. Replace any components that are damaged or worn.



Guard Removal



Disassembled

Fig. 45 DRIVELINE COMPONENTS



6.SPECIFICATIONS

Drive System:	Direct drive. Pto w/shearbolt	Direct drive. Pto w/shearbolt
Engine	<i>n/a</i>	<i>n/a</i>
Chipper capacity:	4" diameter. (takes up to 10" slab)	6" diameter. (takes up to 12" slab)
Chipper housing opening:	4"x10"	6 1/2" x 10"
Rotor size:	25"	30"
Rotor knives number:	4	4
Knife type:	Hardened tool steel	Hardened tool steel
Rotor weight	110lbs	180lbs
Feeding system	Self	Self (Brawn160S)or hydraulic(Brawn160R)
Dimensions(hopper folded):	40"Lx42"x60" H	50"Lx52"x74" H
Hopper opening:	20"x20"	25"x25"
Discharge chute rotation:	360	360
Discharge chute height:	60"	74"
Rated RPM	540- 1000	540-1000
Weight:	Brawn100S-190KGS	Brawn160S-360KGS/Brawn160R-430KGS

7.Exploded drawings and Part list for Brawn100S/Brawn160S/Brawn160R

Brawn100S-001

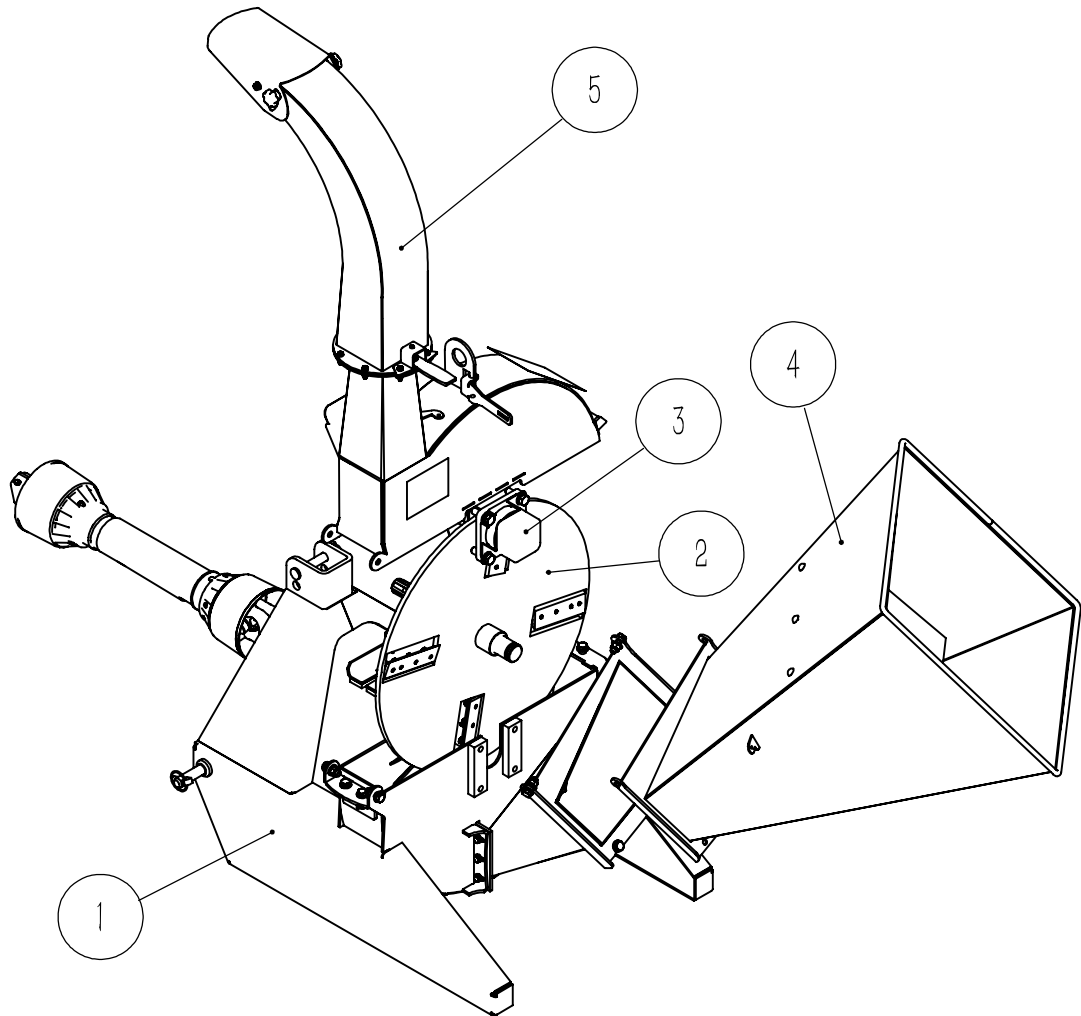

Brawn100S-001

POS.	COD.	Specification	Description	Qty
1	2060105016	W01003A01000-000	Frame Assembly	1
2	2090000286	W01003A02000-000	Assembly,Rotor	1
3	2060105018	W01003A04000-000	Cutter Bearing Assembly	1
4	2060105017	W01003A05000-000	Roller feed parts	1
5	2090000285	W01003A06000-000	Assembly, Discharge Chute	1
6	3160200088	T5S-BS-07-SBT1-800	Drive shaft	1
7	2060105019	W01003A42000-000	Applique Assembly	1

Brawn100S-002

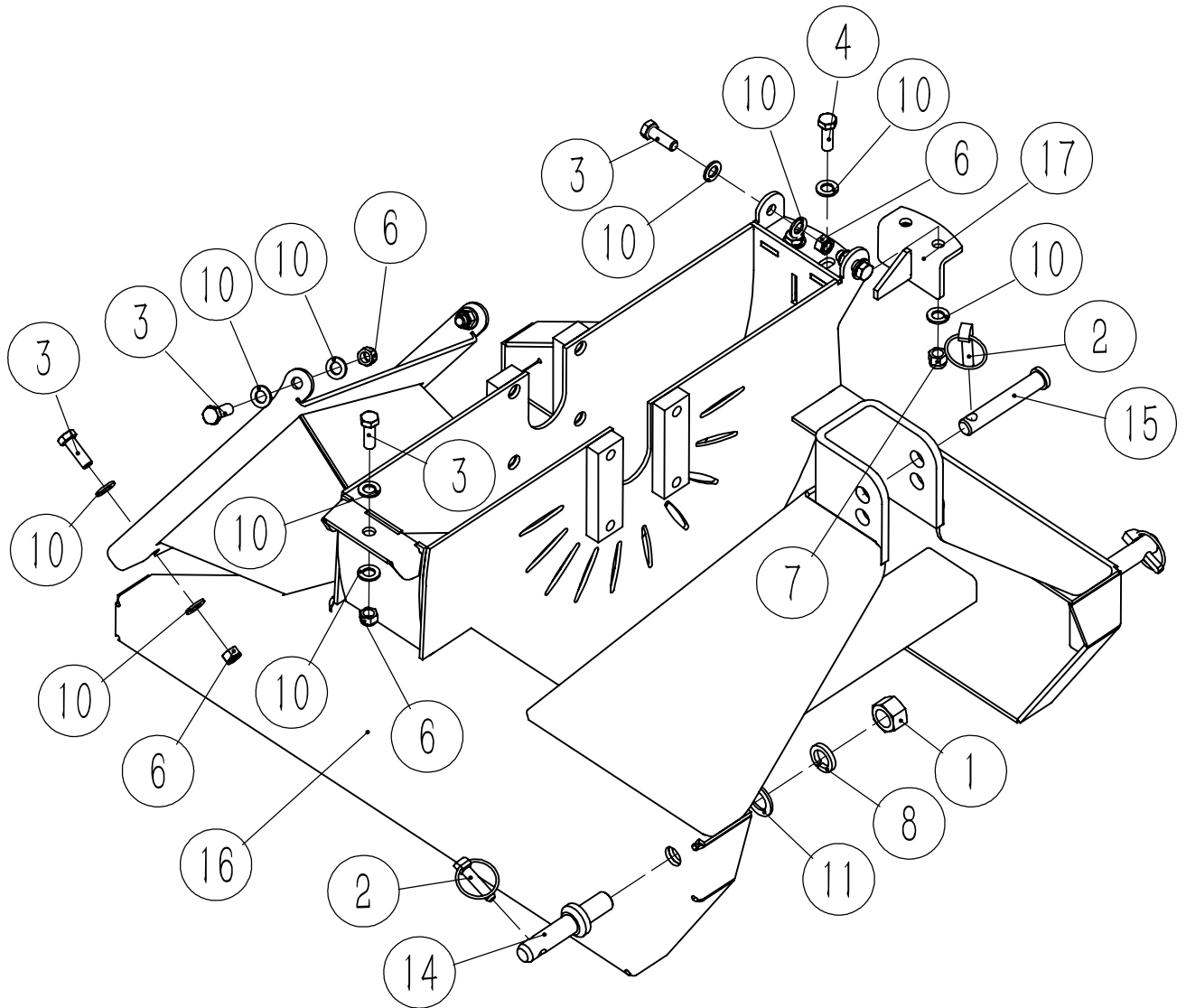

Brawn100S-002

POS.	COD.	Specification	Description	Qty
1	3050100013	GB/T41-M22-5-EP•Zn	Hexagon Nuts	2
2	3120400007	GB/T4329-12-EP•Zn	Pin	3
3	3040100069	GB/T5783-M12×35-8.8-EP•Zn	Full-thread hexagon bolts	7
4	3040200012	GB/T5786-M12×1.25×35-10.9-EP•Zn	Full-thread hexagonal bolts (fine pitch)	2
5	3040200001	GB/T5786-M8×1×20-8.8-EP•Zn	Full-thread hexagonal bolts (fine pitch)	3
6	3050500007	GB/T889.1-M12-8-EP•Zn	Locknut	7
7	3050600004	GB/T889.2-M12×1.25-8-EP•Zn	Locknut (fine pitch)	2
8	3080500014	GB/T93-22-EP•Zn	Spring washer	2
9	3080500007	GB/T93-8-EP•Zn	Spring washer	3
10	3080100007	GB/T95-12-EP•Zn	Plain washer	18
11	3080100012	GB/T95-22-EP•Zn	Plain washer	2
12	3080100004	GB/T95-8-EP•Zn	Plain washer	3
13	3220100018	MT20003	Blade	1
14	3120500011	MT95011	Pin	2
15	3120500007	MT95012	Pin	1
16	2020000561	W01003A01100-000	Housing, Bottom Rotor	1
17	2020000556	W01003A01200-000	Twig Breaker	1

Brawn100S-003

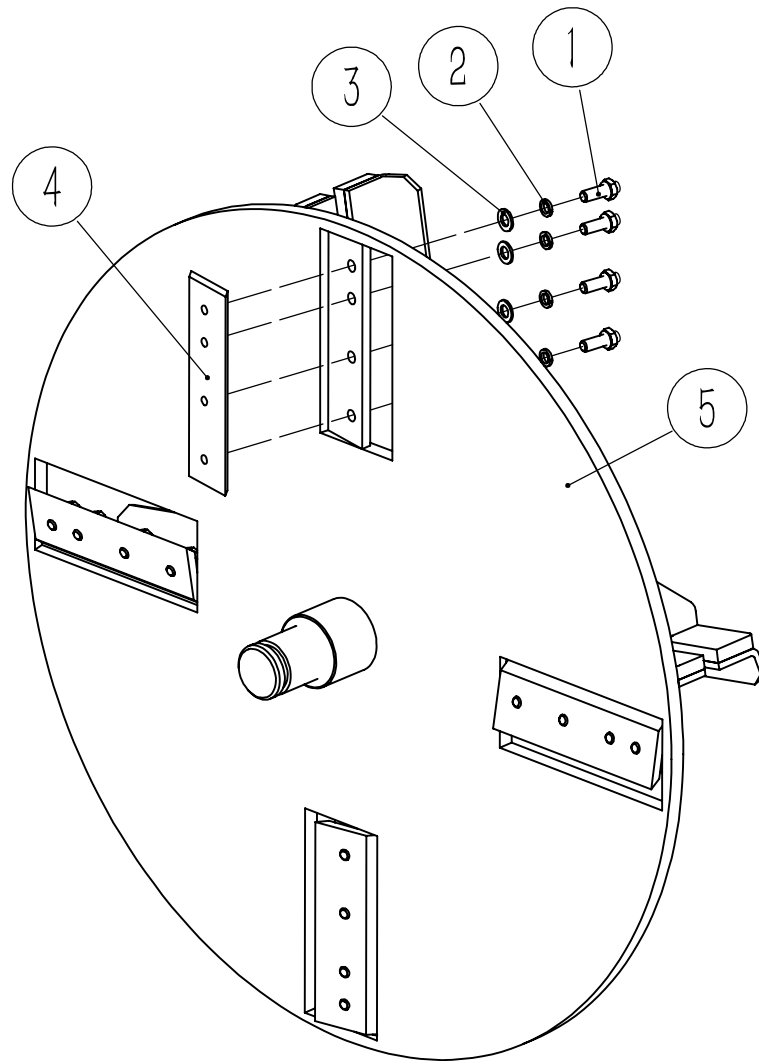

Brawn100S-003

POS.	COD.	Specification	Description	Qty
1	3040200001	GB/T5786-M8×1×20-8.8-EP•Zn	Full-thread hexagonal bolts (fine pitch)	16
2	3080500007	GB/T93-8-EP•Zn	Spring washer	16
3	3080100004	GB/T95-8-EP•Zn	Plain washer	16
4	3220100019	MT21002	Blade	4
5	2020000560	W01003A02100-000	Rotor	1

Brawn100S-004

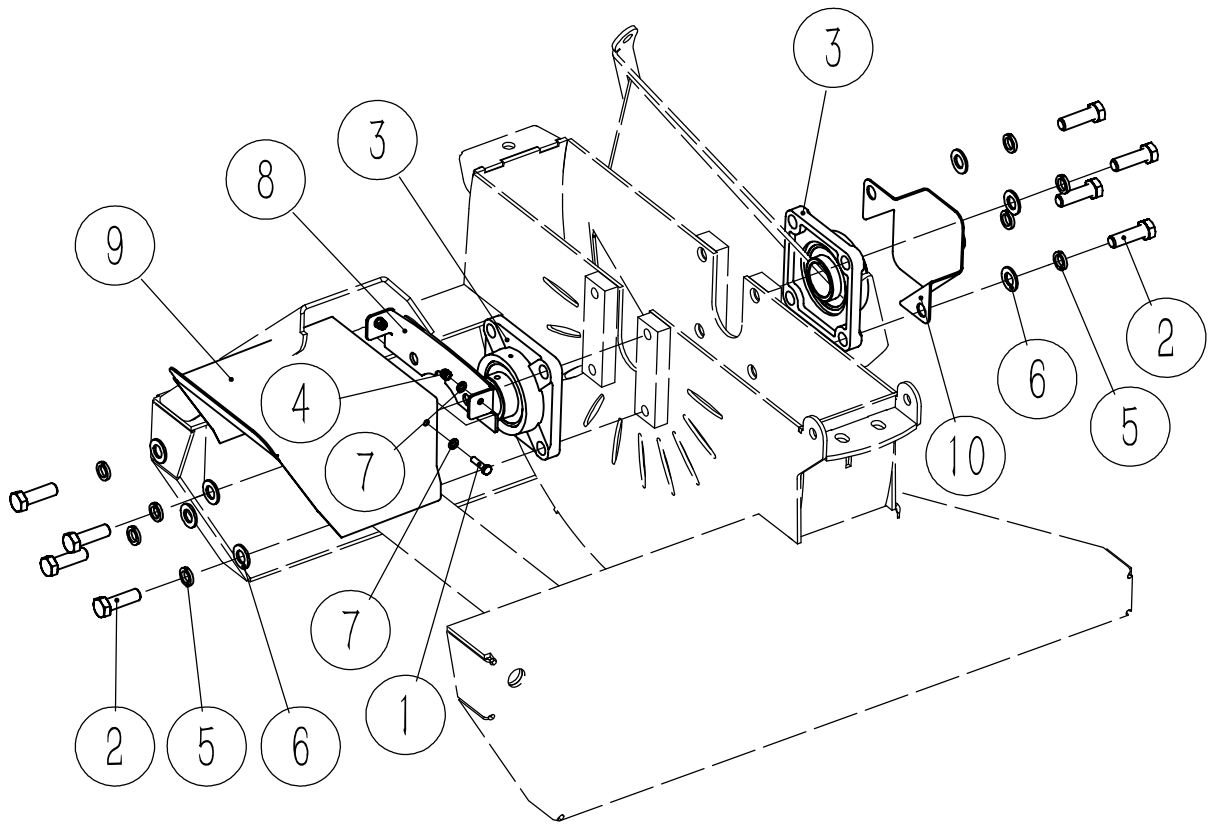

Brawn100S-004

POS.	COD.	Specification	Description	Qty
1	3040100008	GB/T5783-M6×25-8.8-EP•Zn	Full-thread hexagon bolts	2
2	3040200031	GB/T5786-M14×1.5×45-10.9-EP•Zn	Full-thread hexagonal bolts (fine pitch)	8
3	3100700020	GB/T7810-UCF208	Outer Spherical Ball Bearing with Seat	2
4	3050500002	GB/T889.1-M6-8-EP•Zn	Locknut	2
5	3080500010	GB/T93-14-EP•Zn	Spring washer	8
6	3080100008	GB/T95-14-EP•Zn	Plain washer	8
7	3080100003	GB/T95-6-EP•Zn	Plain washer	4
8	2000000304	W01003A04000-001	PTO Cover Mounting Bracket	1
9	2000000303	W01003A04000-002	PTO Cover	1
10	2000001081	W01003A04000-003	Bearing shield	1

Brawn100S-005

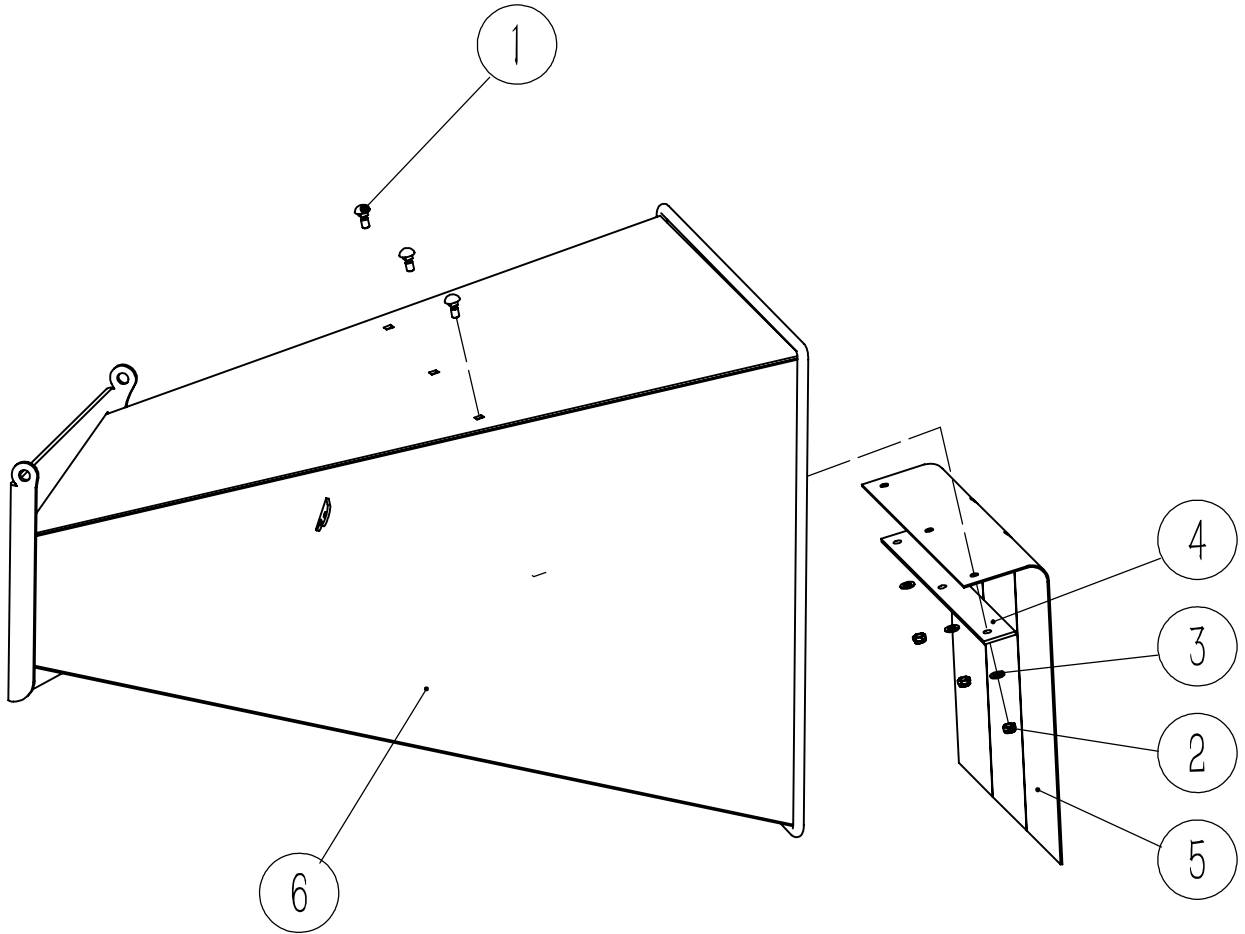

Brawn100S-005

POS.	COD.	Specification	Description	Qty
1	3040800002	GB/T12-M8×20-4.8-EP•Zn	Cup head square neck boltS	3
2	3050500003	GB/T889.1-M8-8-EP•Zn	Locknut	3
3	3080100004	GB/T95-8-EP•Zn	Plain washer	3
4	2000000301	W01003A05000-001	Strap, Hopper Flap	1
5	2000000300	W01003A05000-002	Flap, Hopper	1
6	2020000562	W01003A05100-000	Hopper	1

Brawn100S-006

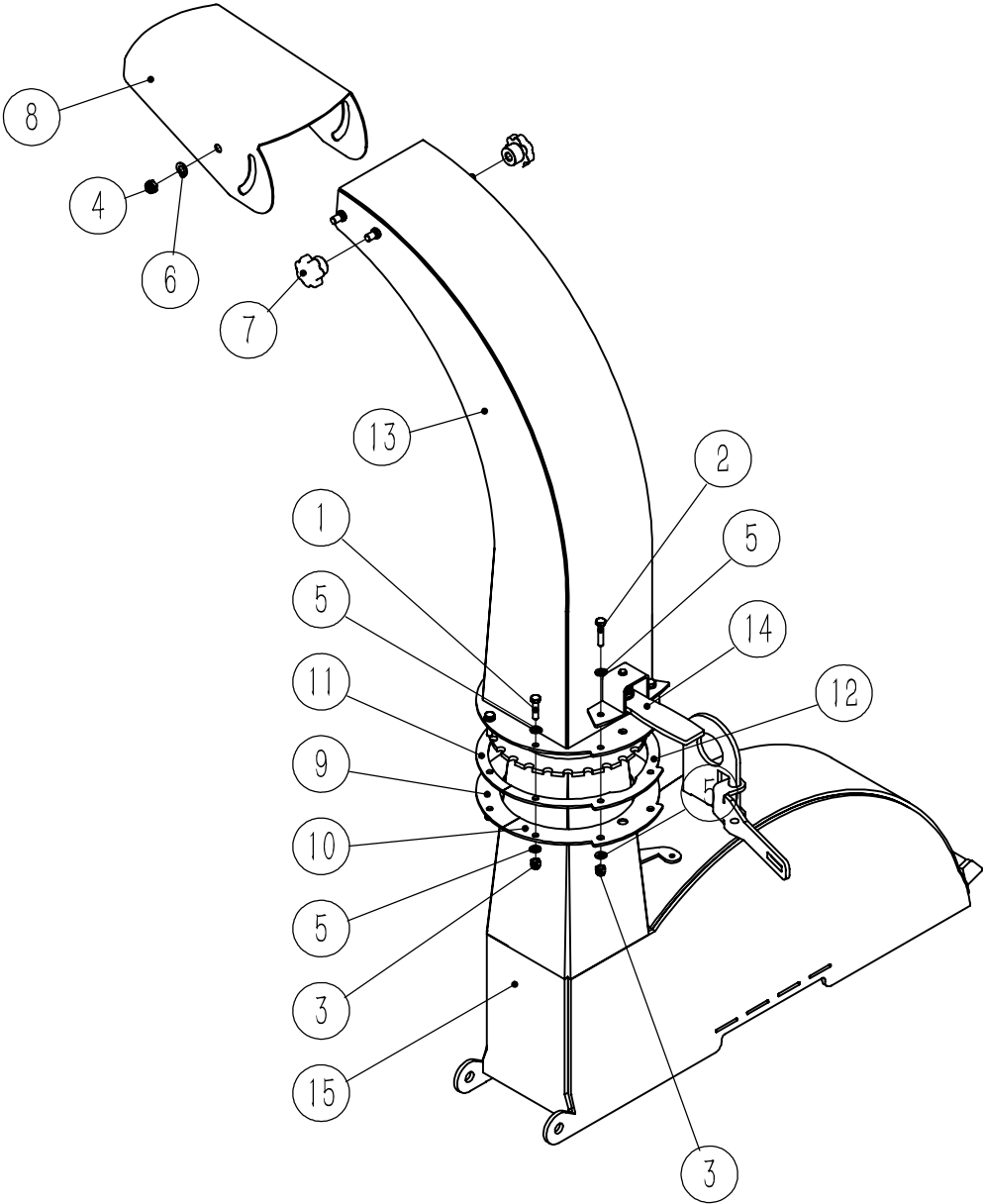

Brawn100S-006

POS.	COD.	Specification	Description	Qty
1	3040100008	GB/T5783-M6×25-8.8-EP•Zn	Full-thread hexagon bolts	6
2	3040100009	GB/T5783-M6×30-8.8-EP•Zn	Full-thread hexagon bolts	2
3	3050500002	GB/T889.1-M6-8-EP•Zn	Locknut	8
4	3050500003	GB/T889.1-M8-8-EP•Zn	Locknut	2
5	3080100003	GB/T95-6-EP•Zn	Plain washer	16
6	3080100004	GB/T95-8-EP•Zn	Plain washer	2
7	3210500016	M8	Seven angle knob nut	2
8	2000000302	W01003A06000-001	Discharge Deflector	1
9	2000000299	W01003A06000-002	Hood Capture Ring (Up)	1
10	2000000298	W01003A06000-003	Hood Capture Ring (Down)	1
11	2000000297	W01003A06000-004	Spacer Ring (Up)	1
12	2000000296	W01003A06000-005	Spacer Ring (down)	1
13	2020000559	W01003A06100-000	Discharge Chute	1
14	2020000558	W01003A06200-000	Assembly, Hood Latch	1
15	2020000557	W01003A06300-000	Housing, Upper Rotor	1

Brawn160S-001

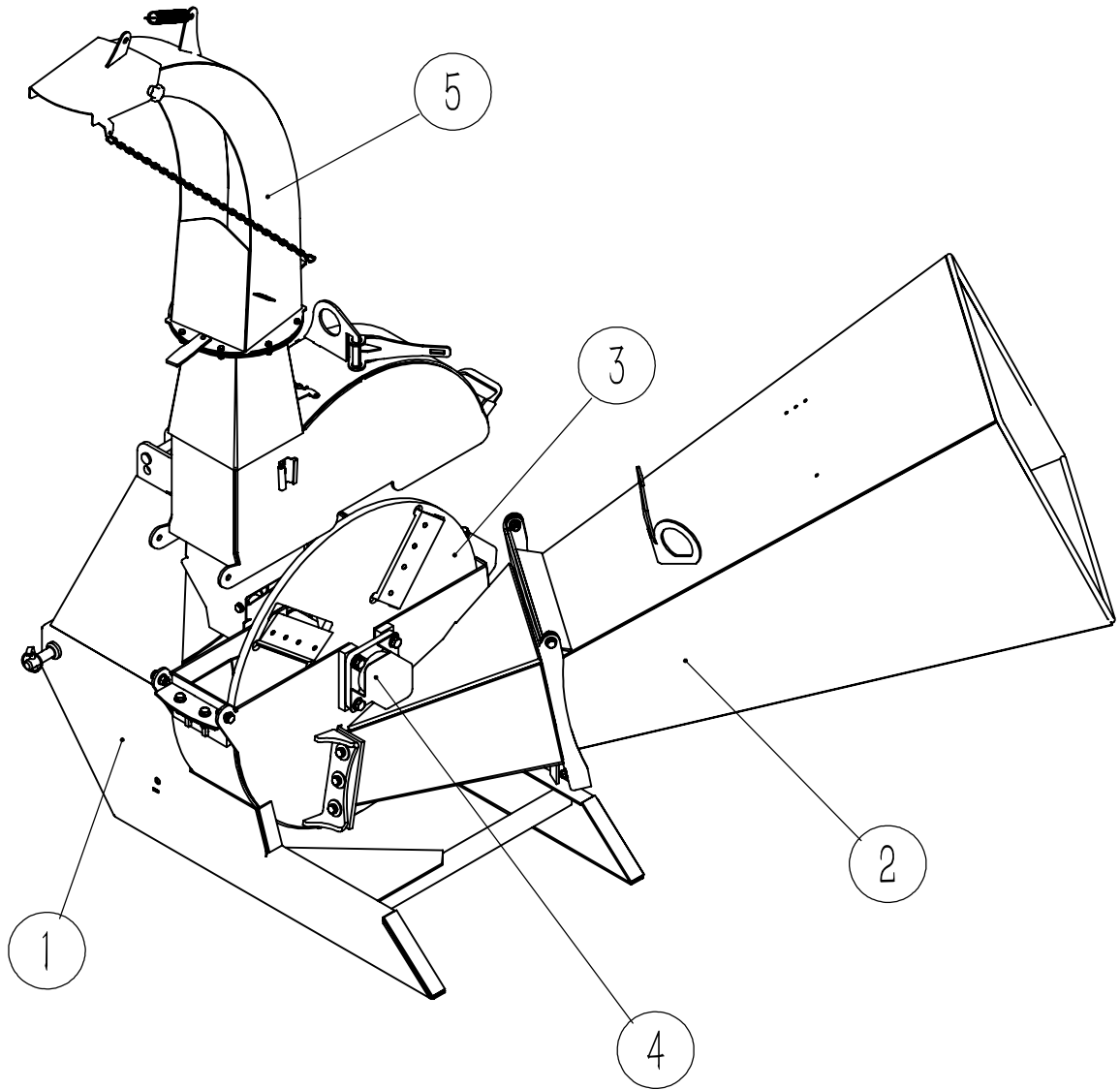

Brawn160S-001

POS.	COD.	Specification	Description	Qty
1	2060105033	W01004A01000-000	Base assembly	1
2	2060105034	W01004A05000-000	Feed assembly	1
3	2090000298	W01005A02000-000	Assembly,Rotor	1
4	2060105031	W01005A04000-000	Bearing block assembly	1
5	2090000299	W01005A06000-000	Assembly, Discharge Chute	1

Brawn160S-002

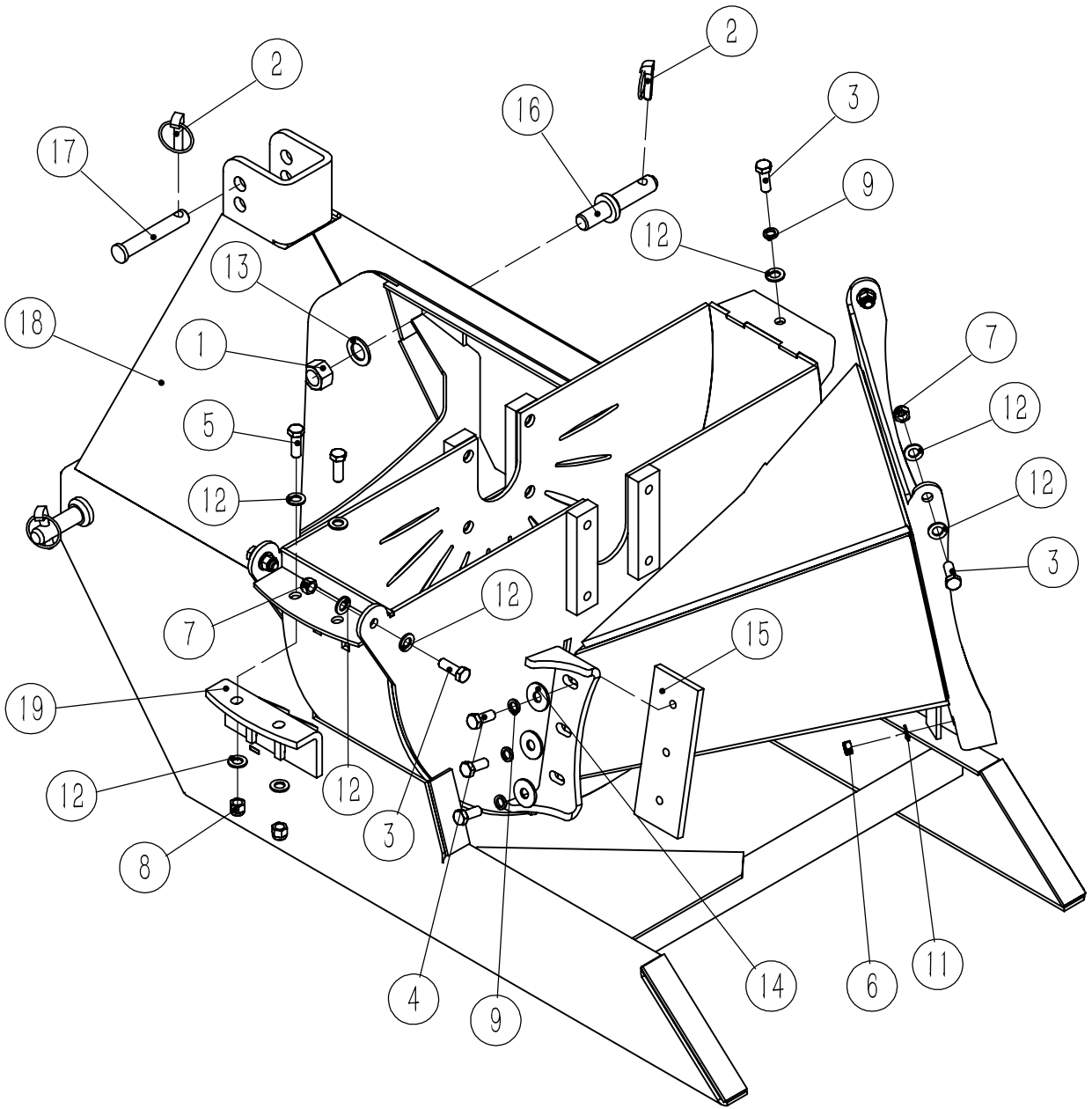

Brawn160S-002

POS.	COD.	Specification	Description	Qty
1	3050100013	GB/T41-M22-5-EP•Zn	Hexagon Nuts	2
2	3120400007	GB/T4329-12-EP•Zn	Pin	3
3	3040100069	GB/T5783-M12×35-8.8-EP•Zn	Full-thread hexagon bolts	5
4	3040200011	GB/T5786-M12×1.25×30-10.9-EP•Zn	Full-thread hexagonal bolts (fine pitch)	3
5	3040200012	GB/T5786-M12×1.25×35-10.9-EP•Zn	Full-thread hexagonal bolts (fine pitch)	2
6	3050500004	GB/T889.1-M10-8-EP•Zn	Locknut	2
7	3050500007	GB/T889.1-M12-8-EP•Zn	Locknut	4
8	3050600004	GB/T889.2-M12×1.25-8-EP•Zn	Locknut (fine pitch)	2
9	3080500009	GB/T93-12-EP•Zn	Spring washer	4
10	3080500014	GB/T93-22-EP•Zn	Spring washer	2
11	3080100006	GB/T95-10-EP•Zn	Plain washer	2
12	3080100007	GB/T95-12-EP•Zn	Plain washer	13
13	3080100012	GB/T95-22-EP•Zn	Plain washer	2
14	3080200010	GB/T96.2-12-EP•Zn	Large plain washer	3
15	3220100021	MT20004	Blade	1
16	3120500011	MT95011	Pin	2
17	3120500007	MT95012	Pin	1
18	2020000695	W01004A01100-000	Housing, Bottom Rotor	1
19	2020000686	W01005A01200-000	Twig Breaker	1

Brawn160S-003

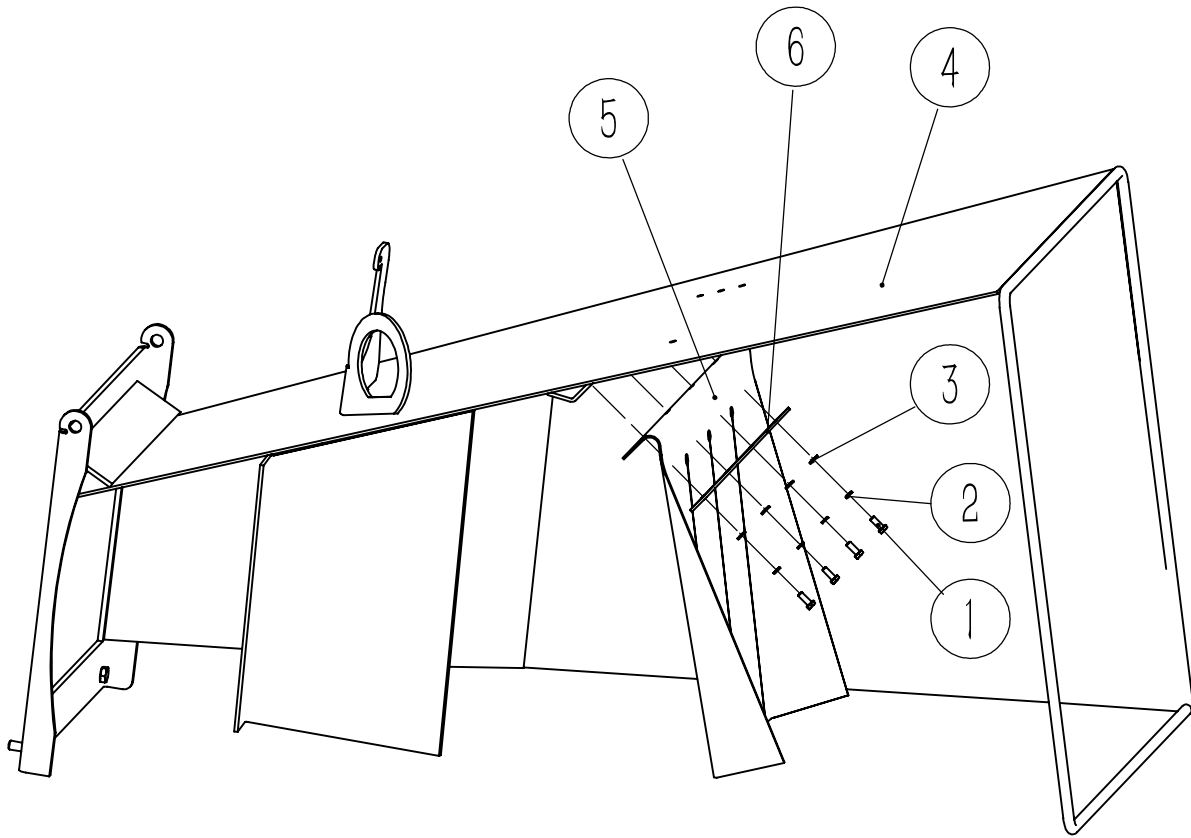

Brawn160S-003

POS.	COD.	Specification	Description	Qty
1	3040100005	GB/T5783-M6×16-8.8-EP•Zn	Full-thread hexagon bolts	4
2	3080500006	GB/T93-6-EP•Zn	Spring washer	4
3	3080100003	GB/T95-6-EP•Zn	Plain washer	4
4	2020000696	W01004A05100-000	Hopper, Self-Feed	1
5	2000000347	W01005A05000-001	Flap, Hopper	1
6	2000000346	W01005A05000-002	Strap, Hopper Flap	1

Brawn160R-001

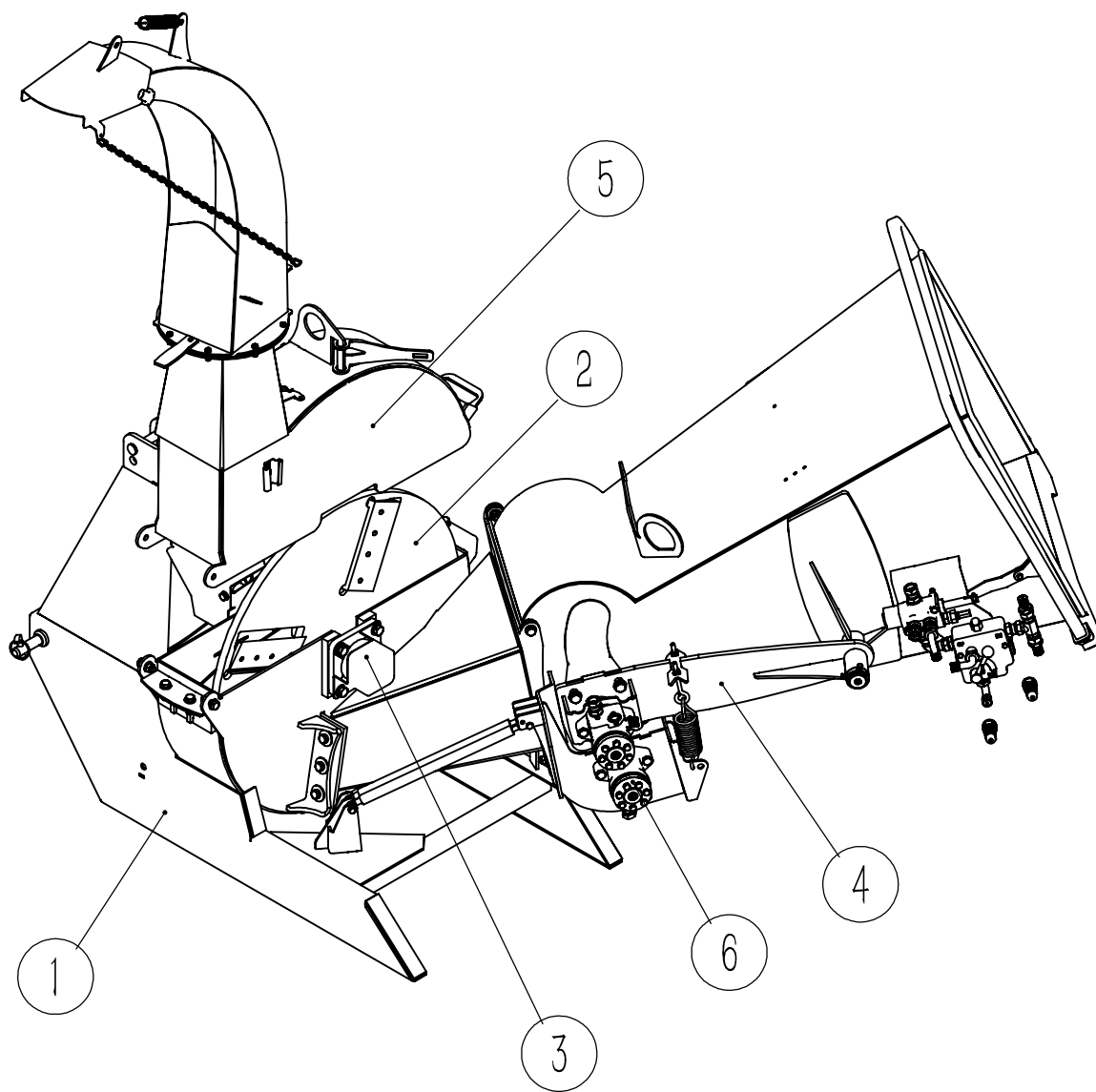

Brawn160R-001

POS.	COD.	Specification	Description	Qty
1	2060105030	W01005A01000-000	Base assembly	1
2	2090000298	W01005A02000-000	Assembly,Rotor	1
3	2060105031	W01005A04000-000	Bearing block assembly	1
4	2090000297	W01005A05000-000	Hydraulic Roller Feed Chute	1
5	2090000299	W01005A06000-000	Assembly, Discharge Chute	1
6	2060105032	W01005A55000-000	Hydraulic System	1

Brawn160R-002

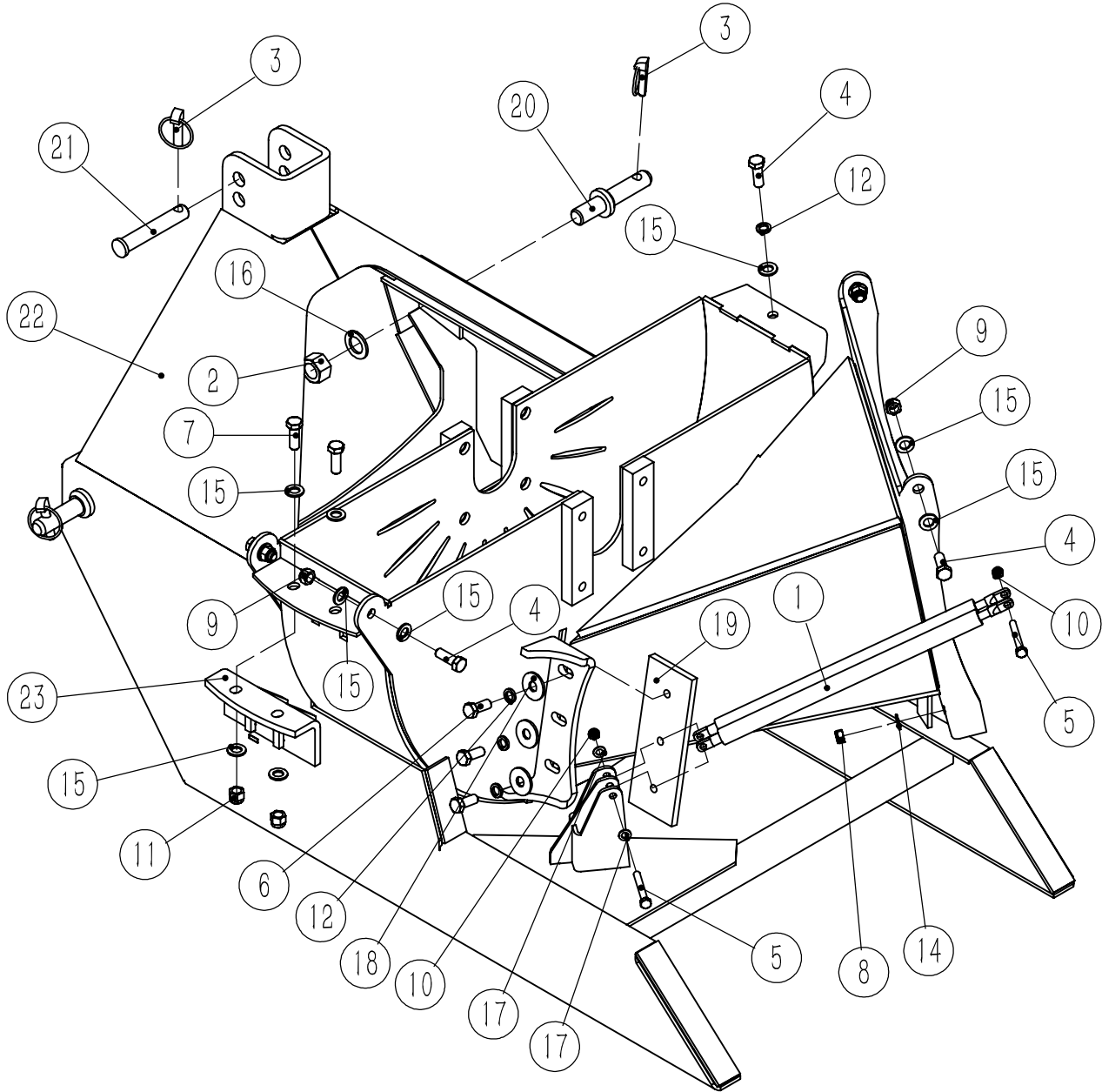

Brawn160R-002

POS.	COD.	Specification	Description	Qty
1	3110400001	1-700×280×1000-1	Gas spring	2
2	3050100013	GB/T41-M22-5-EP•Zn	Hexagon Nuts	2
3	3120400007	GB/T4329-12-EP•Zn	Pin	3
4	3040100069	GB/T5783-M12×35-8.8-EP•Zn	Full-thread hexagon bolts	5
5	3040100031	GB/T5783-M8×65-8.8-EP•Zn	Full-thread hexagon bolts	2
6	3040200011	GB/T5786-M12×1.25×30-10.9-EP•Zn	Full-thread hexagonal bolts (fine pitch)	3
7	3040200012	GB/T5786-M12×1.25×35-10.9-EP•Zn	Full-thread hexagonal bolts (fine pitch)	2
8	3050500004	GB/T889.1-M10-8-EP•Zn	Locknut	2
9	3050500007	GB/T889.1-M12-8-EP•Zn	Locknut	4
10	3050500003	GB/T889.1-M8-8-EP•Zn	Locknut	2
11	3050600004	GB/T889.2-M12×1.25-8-EP•Zn	Locknut (fine pitch)	2
12	3080500009	GB/T93-12-EP•Zn	Spring washer	4
13	3080500014	GB/T93-22-EP•Zn	Spring washer	2
14	3080100006	GB/T95-10-EP•Zn	Plain washer	2
15	3080100007	GB/T95-12-EP•Zn	Plain washer	13
16	3080100012	GB/T95-22-EP•Zn	Plain washer	2
17	3080100004	GB/T95-8-EP•Zn	Plain washer	2
18	3080200010	GB/T96.2-12-EP•Zn	Large plain washer	3
19	3220100021	MT20004	Blade	1
20	3120500011	MT95011	Pin	2
21	3120500007	MT95012	Pin	1
22	2020000683	W01005A01100-000	Housing, Bottom Rotor	1
23	2020000686	W01005A01200-000	Twig Breaker	1

Brawn160R-003

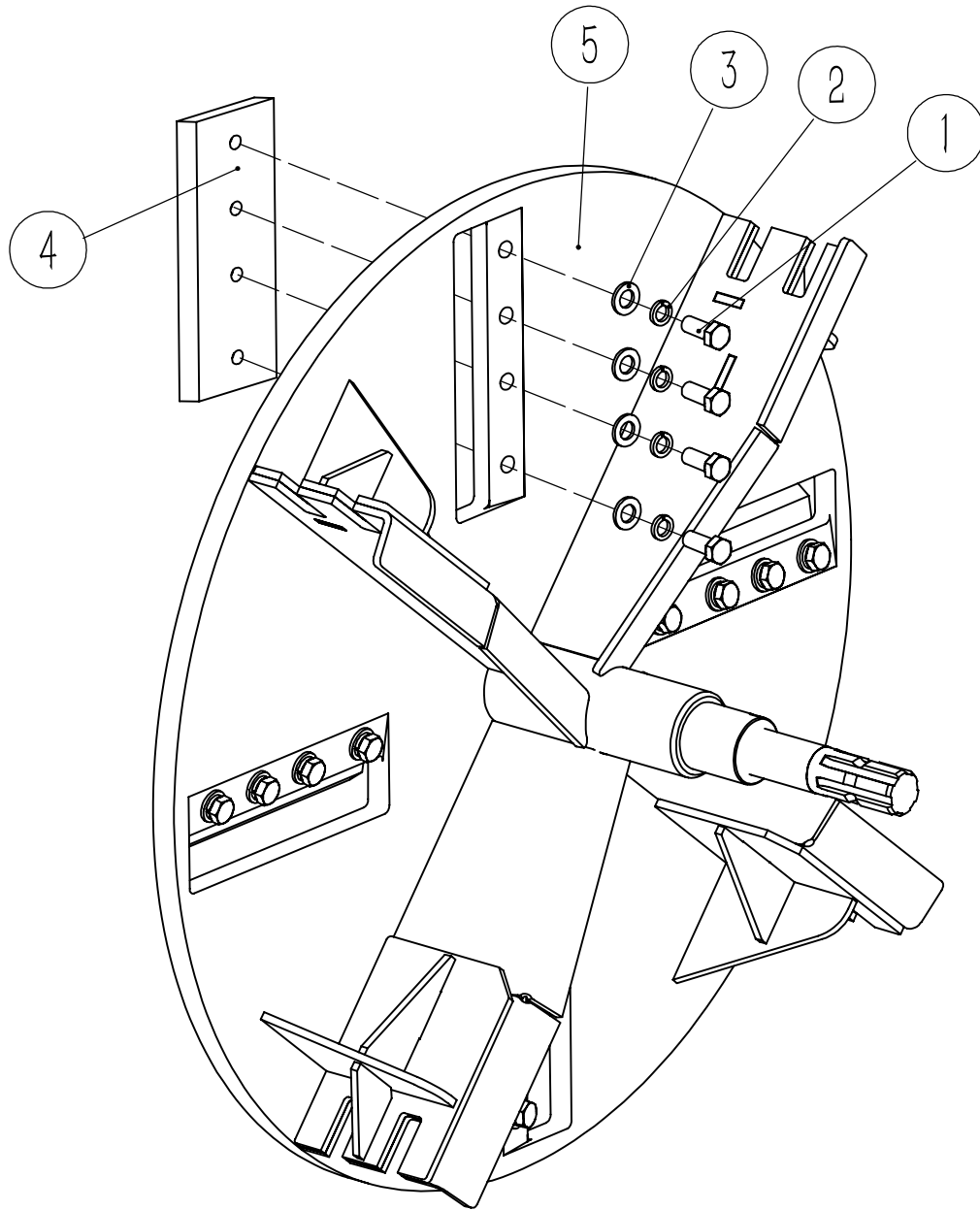

Brawn160R-003

POS.	COD.	Specification	Description	Qty
1	3040200011	GB/T5786- M12×1.25×30-10.9- EP•Zn	Full-thread hexagonal bolts (fine pitch)	16
2	3080500009	GB/T93-12-EP•Zn	Spring washer	16
3	3080100007	GB/T95-12-EP•Zn	Plain washer	16
4	3220100020	MT21003	Blade	4
5	2020000685	W01005A02100-000	Rotor	1

Brawn160R-004

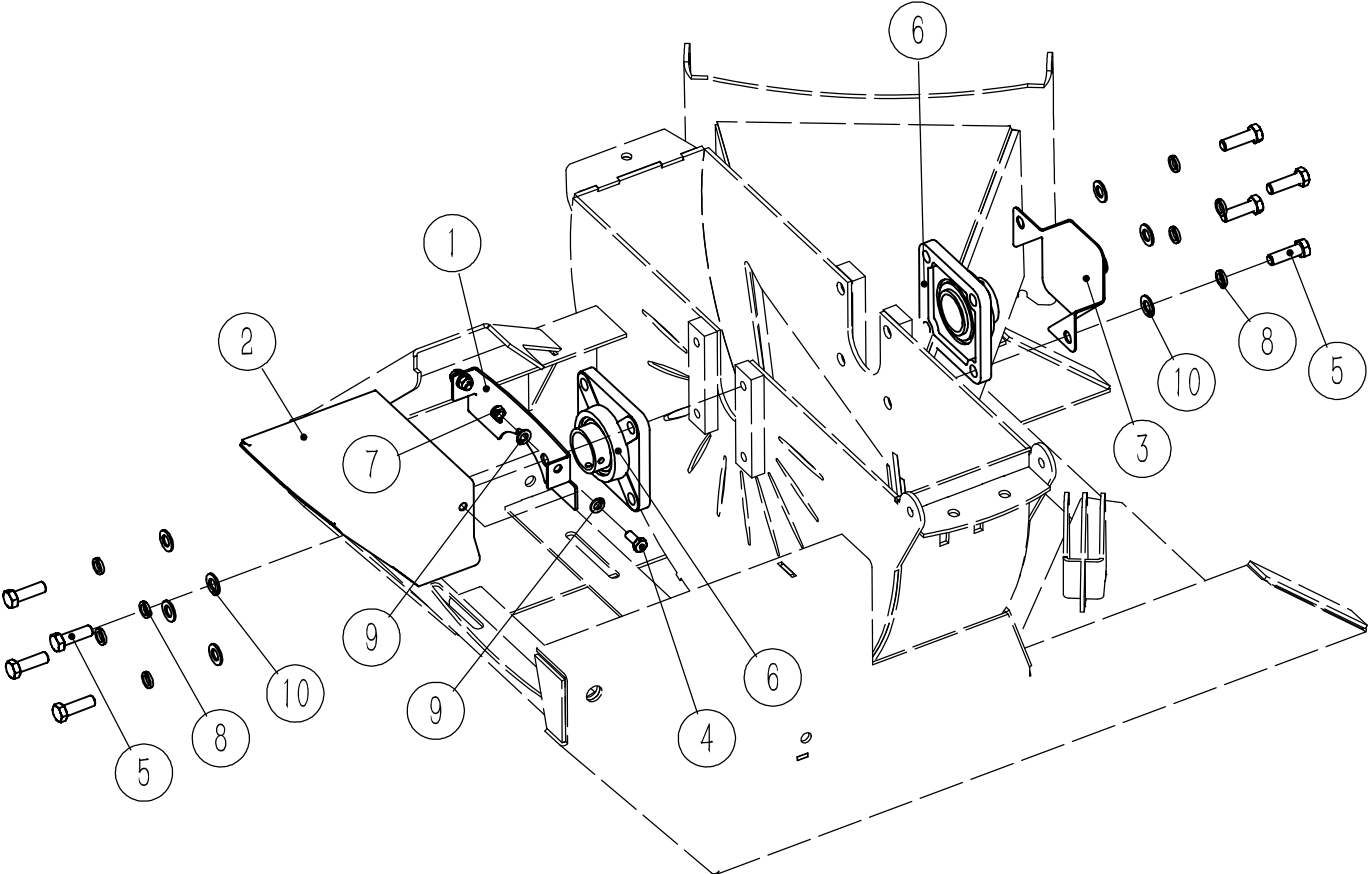

Brawn160R-004

POS.	COD.	Specification	Description	Qty
1	2000000349	W01005A04000-001	PTO Cover Mounting Bracket	1
2	2000000348	W01005A04000-002	PTO Cover	1
3	2000001083	W01005A04000-003	Bearing shield	1
4	3040100043	GB/T5783-M10×25-8.8-EP•Zn	Full-thread hexagon bolts	2
5	3040200031	GB/T5786-M14×1.5×45-10.9-EP•Zn	Full-thread hexagonal bolts (fine pitch)	8
6	3100700021	GB/T7810-UCF210	Outer Spherical Ball Bearing with Seat	2
7	3050500004	GB/T889.1-M10-8-EP•Zn	Locknut	2
8	3080500010	GB/T93-14-EP•Zn	Spring washer	8
9	3080100006	GB/T95-10-EP•Zn	Plain washer	4
10	3080100008	GB/T95-14-EP•Zn	Plain washer	8

Brawn160R-005

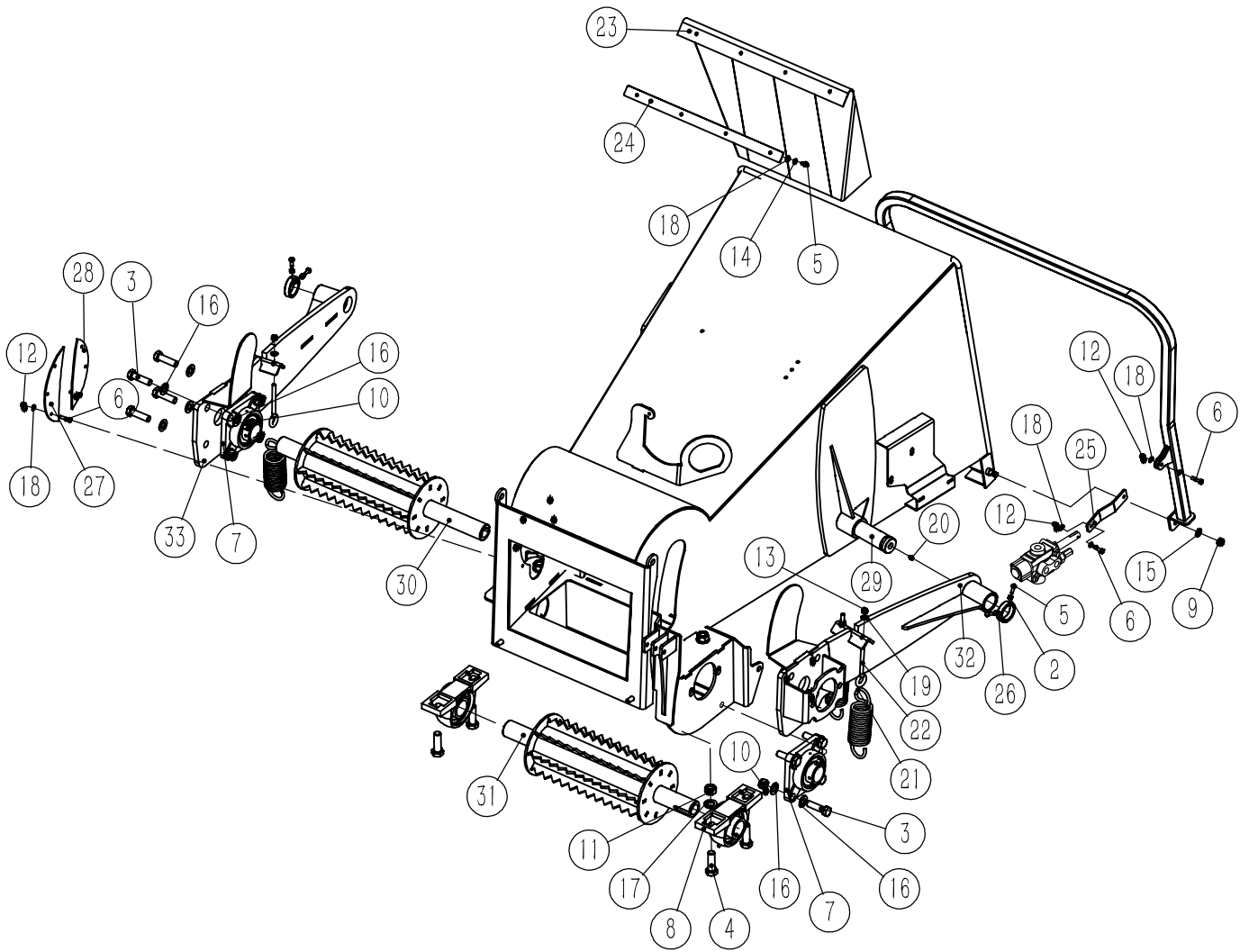

Brawn160R-005

POS.	COD.	Specification	Description	Qty
1	2020000690	W01005A05200-000	Handle, Feed Regulating	1
2	3050100003	GB/T41-M6-5-EP•Zn	Hexagon Nuts	4
3	3040100095	GB/T5783-M14×50- 8.8-EP•Zn	Full-thread hexagon bolts	8
4	3040100108	GB/T5783-M16×50- 8.8-EP•Zn	Full-thread hexagon bolts	4
5	3040100005	GB/T5783-M6×16- 8.8-EP•Zn	Full-thread hexagon bolts	8
6	3040100008	GB/T5783-M6×25- 8.8-EP•Zn	Full-thread hexagon bolts	8
7	3100700020	GB/T7810-UCF208	Outer Spherical Ball Bearing with Seat	2
8	3100700017	GB/T7810-UCP208	Outer Spherical Ball Bearing with Seat	2
9	3050500004	GB/T889.1-M10-8- EP•Zn	Locknut	2
10	3050500008	GB/T889.1-M14-8- EP•Zn	Locknut	8
11	3050500009	GB/T889.1-M16-8- EP•Zn	Locknut	4
12	3050500002	GB/T889.1-M6-8- EP•Zn	Locknut	8
13	3050500003	GB/T889.1-M8-8- EP•Zn	Locknut	4
14	3080500006	GB/T93-6-EP•Zn	Spring washer	4
15	3080100006	GB/T95-10-EP•Zn	Plain washer	2
16	3080100008	GB/T95-14-EP•Zn	Plain washer	16
17	3080100009	GB/T95-16-EP•Zn	Plain washer	4
18	3080100003	GB/T95-6-EP•Zn	Plain washer	14
19	3080100004	GB/T95-8-EP•Zn	Plain washer	4
20	3170400002	JB/T7940.1-M6	Grease nipple	1
21	3110100006	LII-6×45×176×15-R- 65Mn-EP_Zn	Tension spring	4

Brawn160R-005

POS.	COD.	Specification	Description	Qty
22	3041600602	GB/T896- M8×50 (Φ13.5-90) - 4.6-EP•Zn	Eye Bolt	4
23	2000000347	W01005A05000-001	Flap, Hopper	1
24	2000000346	W01005A05000-002	Strap, Hopper Flap	1
25	2000000345	W01005A05000-003	Valve Linkage Bar	1
26	2010000230	W01005A05000-004	Arm Capture Bushing	2
27	2000000342	W01005A05000-005	Up cover plate	1
28	2000000341	W01005A05000-006	Down cover plate	1
29	2020000689	W01005A05100-000	Hopper, Roller Feed	1
30	2020000691	W01005A05300-000	Roller, Upper Feed	1
31	2020000692	W01005A05400-000	Roller, Lower Feed	1
32	2020000693	W01005A05500-000	Arm, Upper Roller	1
33	2020000694	W01005A05600-000	Arm, Upper Roller	1

Brawn160R-006

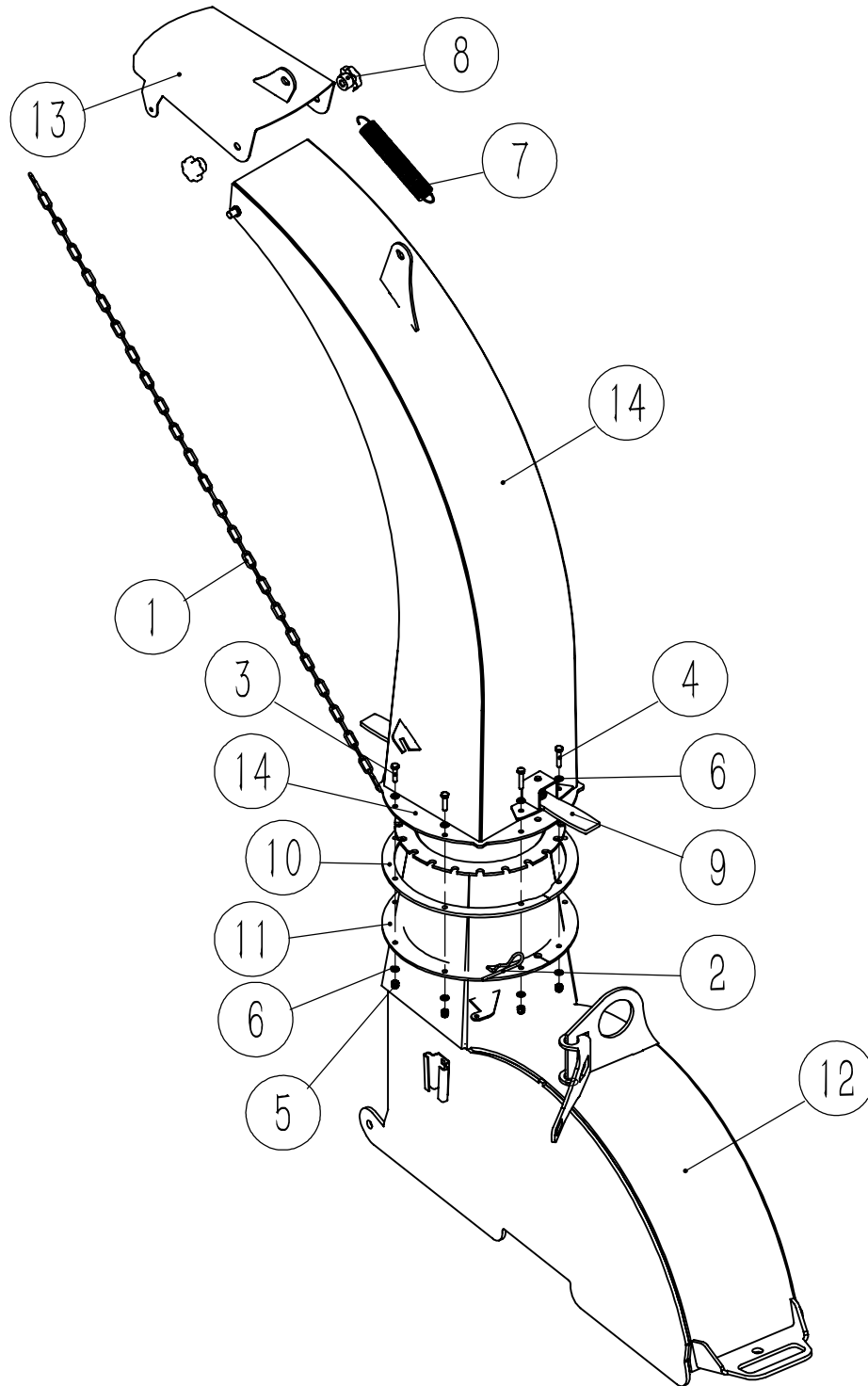

Brawn160R-006

POS.	COD.	Specification	Description	Qty
1	2020000688	W01005A06300-000	Discharge Chute	1
2	2020000687	W01005A06200-000	Discharge Deflector	1
3	2020000558	W01003A06200-000	Assembly, Hood Latch	1
4	3080100003	GB/T95-6-EP•Zn	Plain washer	16
5	3050500002	GB/T889.1-M6-8-EP•Zn	Locknut	8
6	2000000344	W01005A06000-001	Spacer Ring	2
7	2000000343	W01005A06000-002	Hood Capture Ring	2
8	3040100008	GB/T5783-M6×25-8.8-EP•Zn	Full-thread hexagon bolts	6
9	3040100009	GB/T5783-M6×30-8.8-EP•Zn	Full-thread hexagon bolts	2
10	3210500013	M10	Seven angle knob nut	2
11	3130100009	3×22×15-47	Galvanized chain	1
12	3110100007	LI-2.5×25×184.5×55-L-65Mn-EP_Zn	Tension spring	1
13	2020000684	W01005A06100-000	Housing, Upper Rotor	1
14	3120400008	Din11024-4-EP•Zn	R Pin	1

Brawn160R-007

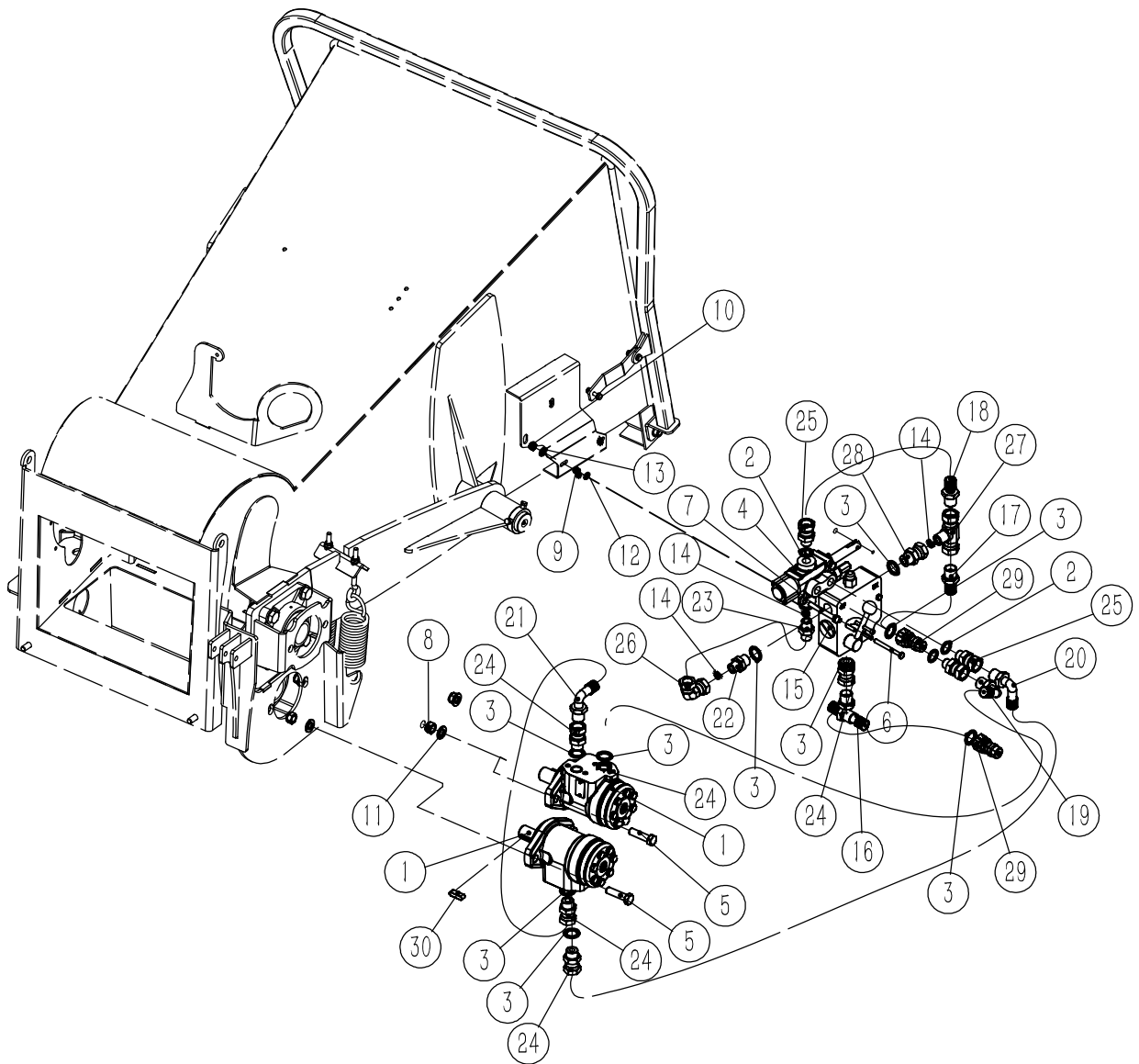

Brawn160R-007

POS.	COD.	Specification	Description	Qty
1	3181000002	155200A6312AAAAA	Hydraulic motor	2
2	3170300013	BS-18.4×25×2.5-Q235	Combined sealing gaskets	4
3	3170300006	BS/A-21.5×28.6×2.5-Q235	Combined sealing gaskets	9
4	3180700020	DBL40-0TW/03	Hydraulic Valve	1
5	3040100072	GB/T5783-M12×45-8.8-EP•Zn	Full-thread hexagon bolts	4
6	3040100017	GB/T5783-M6×65-8.8-EP•Zn	Full-thread hexagon bolts	2
7	3040100031	GB/T5783-M8×65-8.8-EP•Zn	Full-thread hexagon bolts	2
8	3050500007	GB/T889.1-M12-8-EP•Zn	Locknut	4
9	3050500002	GB/T889.1-M6-8-EP•Zn	Locknut	2
10	3050500003	GB/T889.1-M8-8-EP•Zn	Locknut	2
11	3080100007	GB/T95-12-EP•Zn	Plain washer	4
12	3080100003	GB/T95-6-EP•Zn	Plain washer	2
13	3080100004	GB/T95-8-EP•Zn	Plain washer	2
14	3170200002	GB3452.1-10×2-NBR-70	O-Ring	3
15	3180700021	LKF.60 (1 / 2G)	Hydraulic Valve	1
16	3181100620	MT40005	Hydraulic hose	1
17	3181100623	MT40006	Hydraulic hose	1
18	3181100624	MT40007	Hydraulic hose	1
19	3181100625	MT40008	Hydraulic hose	1
20	3181100622	MT40009	Hydraulic hose	1
21	3181100626	MT40010	Hydraulic hose	1
22	3181100619	MT85009	Adapter G1/2 Male-M18x1.5 Male	1