

Operation Manual of Wheeled Tractors

TB Series 40-80hp



WEIFANG SINOVOL MACHINERY CO.,LTD
NO.222,SIPING ROAD,WEIFANG,261000,CHINA

Record Sheet for Product Identification Marks

Product Trademark	
Product Model	
No. for Complete Appliance	
Identification Number	
Engine Model	
Engine No.	
Procurement Time	
Procurement Place and Contact Information	
User name	
Name of Supplier	Weifang Sinovol Machinery Co.Ltd
Address of Manufacturer	No.222,Siping road,Weifang,261000,China
Telephone Number of Manufacturer	0086 -18553692856
Notes: 1. Users shall carefully fill in this sheet when purchasing a tractor; 2. The No. in this sheet shall be completely recorded (including letters).	

User Guide

Dear Customer:

Thank you for your trust in our company and for purchasing the SINOVOL TB series wheeled tractor manufactured by us. To enable you to use this tractor correctly, properly and efficiently, please pay attention to the following important information:

1. Before using this tractor, read this manual carefully whether you have ever driven or not. This will help you operate this tractor more reasonably and efficiently.

2. To bring you more economic benefits and prolong service life of your tractor, please read this manual and the operation manuals of the engine and farm implements matching this machine carefully before you use this product and follow the provisions in these manuals strictly to operate, service and maintain your tractor properly so as to make full use of its performance.

3. Please do not refit your tractor at will so as to avoid affecting its performance and occurrence of accident. Failure to observe this will also cause difficulty in performance of the “Three Guarantees” service.

4. The purposes, parameters, matching farm machines and implements and work efficiency may differ a little because conditions of regional agriculture and soil differ a lot. You can make choices according to your practical situations.

5. Have this tractor operated, serviced and maintained only by the personnel who are familiar with characteristics of this machine and command related safe operation knowledge.

6. The driver must have the driver’s license issued by local traffic department for driving of agricultural vehicles and tractors.

7. You should observe “Law of the People's Republic of China on Road Traffic Safety” “Regulations for the Implementation of the Road Traffic Safety Law” and other safety regulations and road traffic rules at any time to prevent accident.

8. Do not exceed the regulations set forth in this manual during use; otherwise, tractor performance reduction or accident may result.

9. This manual is not a product quality guarantee, so, you shall not lodge any claim on the basis of any data, illustration and instruction in it.

10. All descriptions in this manual are based on the product structure at the time of publication and they are subject to change without prior notice, for which we hereby request your attention.

Overview

This manual describes safety precautions as well as running-in, use, technical maintenance, adjustment, faults and their troubleshooting methods, etc. for various parts of the SINOVOL TB series wheeled tractors in detail for reference of tractor drivers and maintenance personnel.

In this manual, the safety alert symbol  prompts important safety information. When this symbol is seen, you should be alert to possible injuries or affect to service performance of the machine.



Warning: Means that, if not avoided, potential hazards that will cause death or serious injuries may occur.



Notice: Means that, if not avoided, potential hazards that will cause minor or medium injuries may occur.

Important issue: Describes some issues may cause machine or environmental damages.

Note: Describes some additional information.

Please read the messages that follow the symbol carefully and let other operators know them.

This manual will come with the tractor. Please keep it properly.

If you encounter any sections that you could understand during use of this manual, please call the service telephone 0086-18553692856 or Email service@sinovol.com to consult.

Intended Use

The SINOVOL TB series wheeled tractors are a kind of multi-purpose medium-sized farm wheeled tractors. They have such advantages as compact structure, easy control, smart steering, large traction force, extensive purposes, and convenient service and maintenance. If equipped with appropriate farm implements, they can carry out such tasks as plowing, harrowing, sowing, and harvesting; if equipped with trailers, they can carry out carry operations for agricultural purposes, but ensure that the trailer/towing vehicle mass ratio (the ratio between the total mass of the trailer and the complete machine mass of the tractor) should not be greater than 3; if connected with straw returning shredders through PTO shafts, they can carry out straw returning tasks; they can also serve as motive power of water pumps and threshers. Please match the farm machines and implements correctly according to the requirements in this manual (see Appendixes 10 table 10.5) to obtain the maximum economic benefits. The agricultural tractors can not be used in conditions which may cause the risk of contact with hazardous substances, e.g. spraying of pesticides. In addition, the agricultural tractors also can not be used in conditions which may cause risk of falling and penetrating objects.

Users shall observe the working, maintenance and service conditions specified by the maker as well as the essential requirements for the expected purposes strictly. Using this tractor for other operations will breach its expected purposes.

Have this tractor operated, serviced and maintained only by the personnel who are familiar with characteristics of this machine and command related safe operation knowledge.

You must observe the accident prevention rules as well as other safety regulations and road traffic rules at any time.

The manufacturer will never be liable for any reliability reduction or damage of the machine or personal injury resulted from any unauthorized re-manufacturing of this machine or using this tractor for the tasks that breach its expected purposes.

Chinese-English Contrast Table of Common Units

No.	Unit category	International unit
1	Time	s
2		min
3		h
4	Length	mm
5		cm
6		m
7		km
8	Force	N
9		K/N
10	Moment	N·m
11	Mass	kg
12		g
13	Pressure	Pa
14		K/Pa
15		M/Pa
16		Kg.f/cm ²
17	Temperature	°C
18	Velocity	km/h
19	Speed of rotation	r/min
20	Current	A
21	Voltage	V
22	Volume	L
23		ml
24	Flow	L/min
25	Power	kW
26		PS
27	Oil consumption	g/kW·h
28	Battery capacity	A·h

Contents

1. Safety precautions -----	1
1.1 Safety rules and notices of use-----	1
1.2 Safety warning symbols-----	11
2 Products Marking -----	15
3. Operation instructions -----	17
3.1 Product description-----	18
3.2 Operating mechanism and instrument of tractor-----	18
3.3 How to start engine-----	24
3.4 How to start tractor-----	27
3.5 How to steer tractor-----	28
3.6 How to gear shift tractor-----	28
3.7 How to operate differential lock-----	31
3.8 How to user front drive axle-----	32
3.9 How to brake tractor-----	32
3.10 How to stop tractor and how to flameont engine-----	33
3.11 How to use and assemble/disassemble tyre-----	36
3.12 How to use counter weight-----	36
3.13 How to adjust driver’s seat-----	39
3.14 Tractor covers-----	40
3.15 How to use operating device of tractor-----	51
3.16 Tractor running-in-----	63
3.17 Troubleshooting for tractor-----	68
4. Accessories, spare parts and consumables -----	78
4.1 Accessories-----	78
4.2 Documents, spare parts and facilities provided with the machine-----	79
4.3 Wearing part-----	81
5. Maintenance instructions -----	83
5.1 Technical maintenance regulations-----	83
5.2 Operations for Technical Maintenance-----	87
5.3 Tractor chassis adjustment-----	98

6. Storage -----	115
6.1 Causes of the damages occurred during storage of the tractor-----	115
6.2 Tractor’s seal-up-----	115
6.3 Maintenance during the tractor’s storage-----	116
6.4 Tractor break-seal-----	116
7. Delivery, acceptance and transportation -----	117
7.1 Delivery and acceptance-----	117
7.2 Transportation-----	117
8. Main technical specifications of tractors -----	119
8.1 Type of product-----	119
8.2 Product Technical specifications-----	120
8.3 Theory speed of the tractor-----	128
9. Disassembly and disposal -----	130
10. Warranty terms -----	131
10.1 Product warranty basis-----	131
10.2 Cases not covered by the warranty policies-----	131
11. Appendixes -----	132
11.1 Oils and solutions used on the tractor-----	132
11.2 Tightening torque table of major bolts and nuts-----	133
11.3 Reinforced seal and O-ring seal-----	134
11.4 Rolling bearings-----	135
11.5 Supporting farm machines and implements-----	137

Customer Information Feedback Form

1. Safety precautions

1.1 Safety rules and notices of use

Reading prior to use

1. The instructions for use and maintenance and the safety warning identifiers have to be fully read and understood.
2. The correct manipulation and operating method have to be kept in mind.
3. The traffic rules and the safety advices must be observed

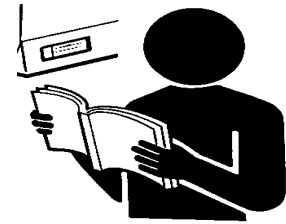

Fig. 1-1 Reading prior to use

An qualified operator

1. When operating the machine, the driver must be able enough for sound judgment.
2. Persons feeling not well, drunk, short of sleeping, pregnant women, color blindness and those under 18 year-old are not allowed to operate the machine.
3. . The driver should have received the special training, acquired the driving license and subject to the proof-test on time.
4. In case of first driving, the operator is required to drive slowly before skilled.
5. When the machine is flameout and parked at the safety position, the driver can get on the tractor through left door or right door by steps.
6. The driver can leave the tractor through left door or right door by steps only when he has driven the tractor to a safety position and flamed out.



Fig.1-2 An qualified operator

Driver's clothes

During the operation, the driver should put on the tight-fitting work clothes. The large coat and the shirt as well as tie are not allowed.



Fig.1-3 Driver's clothes

Use of fuel

1. The fuel is the combustible substance, fire is strictly prohibited when in use.
2. Prior to tank refueling, the engine should shut down.
3. Smoking is strictly prohibited when the fuel system is refueled and overhauled.
4. Use clean rag to wipe out in case of fuel or machine oil overflow.
5. The requirements set out in the "Appendix" must be strictly complied with for the fuel and the lubricating oil quality.



Fig.1-4 Use of fuel

Safe change of working fluid

1. The working liquid is dangerous and will cause serious personal injury, such as high-pressure hydraulic oil, brake fluid and engine oil, etc.
2. Prior to changing working fluid, it's required to switch off engine and prohibit smoking; when any working fluid overflows, please wipe it with clean cloth.
3. Change working liquid based on correct brand.
4. The replaced working liquid is waste oil which cannot be discarded at will.

Precautions for maintenance of tyre

1. Failure to mount and dismount the tyre according to specified procedures may cause explosion and subsequent serious casualties; therefore, don't mount and dismount the tyre when there is no proper equipment and safe working experience.
2. The correct inflation pressure of tyre must be maintained; don't exceed the specified max. inflation pressure of tyre. When the max. pressure is exceeded, it may cause crack at the edge of tyre and even explosion. When the recommended inflation pressure is reached, if the edges on both sides of tyre still haven't been positioned, the tyre shall be deflated and re-positioned and its edge shall be lubricated for reinflation.
3. Inspect and retighten the tightening torque of fixing nuts and bolts of front and rear rims on a regular basis to prevent turnover of vehicle, serious injury of operator and serious damage of machine due to coming off of wheel.

Disposal of waste oils and wastes

1. Improper disposal of waste oils and wastes will threaten the environment and ecological environment.
2. When the waste oil is discharged, the leak proof container shall be used; the waste oil is not allowed to be placed into the container which is used to contain food and drink to prevent drinking accidentally by others and leading to accidental injury.
3. It's prohibited to pour the wastes onto the ground and into sewer and other water sources.



Fig.1-5 Disposal of wastes

4. The wasted engine oil, fuel, refrigerating fluid, braking fluid, filter element or battery with potential hazard shall not be discarded at will; please consult local environmental protection environment or recycling center to recycle or dispose wastes in a correct way.

Passing beneath living and industrial power cables

1. Every part of machine shall be fixed firmly to prevent looseness and resultant electric shock.
2. When passing beneath the hanging living and industrial power cables at a low speed, it's required to ensure that the height of the highest point of machine conforms to the allowable safety height of cable so as to avoid touching the cable and prevent electric shock.

3. The machine is prohibited to collide with high-voltage line when it's in transport, working and shutdown state to prevent electric shock hazard.

Correct support of tractor

1. Parts or implement should fall to ground. If the tractor or its parts must raise, they must be supported safely.
2. Don't use cinder, air brick, tile or other supports which are easily disintegrated under persistent pressure to support the machine.
3. Don't work under the tractor which is supported by only one jack.
4. Before operating the jack, it is necessary to read the operation manual. It is forbidden to overload. The jack should be on the hard ground to prevent personal injury or property loss.
5. The jack should support just below of tractor rear-axle left and right semi-shaft shell and front support. Other parts are not allowed to support.

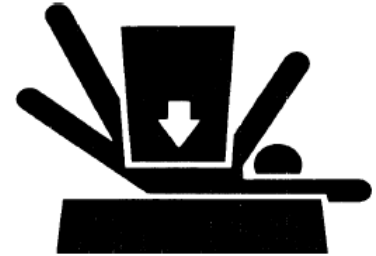

Figure 1-6 support danger

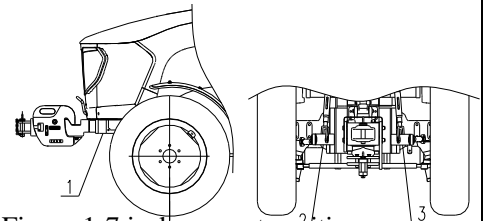

Figure 1-7 jack support position

- 1、 front support
- 2、 left semi-shaft shell
- 3、 right semi-shaft shell

Emergency exit of the cab

The cab has three exits which are left door, right door and rear window. The rear window is the emergency exit. Under the emergency situation, the driver can open the rear window by rotating back window unlocking handle clockwise to leave the cab.

In addition, the driver can use the breaking tool to break the big enough glass to leave the tractor under the emergency situation.

Avoid touching moving part

1. When the machine is operating, please don't lubricate, maintain, repair or adjust it; these operation shall not be executed until all the parts stop moving.
2. Keep the hands, feet and clothes away from moving transmission parts.



Fig. 1-8 Keep away from moving parts

Pay attention to hydraulic pipeline

1. The high-pressure hydraulic oil has enough force to penetrate and damage the hands, eyes and skins, therefore, prior to inspecting and maintaining hydraulic pipeline, it's required to inspect the possible leakage point by paperboard or woodboard after the pressure of hydraulic system is relieved so as to prevent injury of hands and body by high-pressure fluid.

2. If anyone gets hurt by leaked hydraulic oil, he/she shall be sent to the hospital for treatment, and failure to receive necessary treatment may cause serious infection and reaction.

3. Heating near pressurized fluid pipeline will generate flammable spray and cause serious burn to himself/herself or the adjacent persons. Therefore, please don't heat near the pipeline. It's prohibited to heat by electric welding, gas welding or welding torque near pressurized fluid pipeline or other flammable materials, because the thermal radiation other than flame will damage the pipeline accidentally.

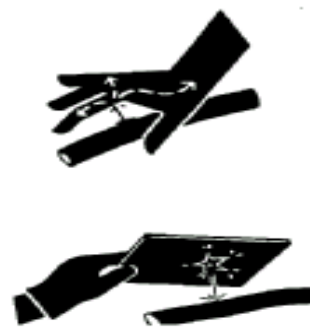

Fig. 1-9 Leakage of hydraulic pipeline

Riding of others

1. Only the driver is allowed to operate the machine; all other persons are not allowed to take the machine without assistant seat, and the machine with assistant seat is allowed to carry one passenger only, but in no case this will interfere, influence and block the operating activity of driver.

2. Under starting and working state of machine, anyone is not allowed to go up and down or climb up the machine, and shall be kept away from the machine to avoid injury.

Disposal of emergency event

1. In case of brake failure, it's required to stabilize the steering wheel, drive the vehicle to a safe place and shut down the engine immediately.

2. In case of faulty steering wheel, please apply the brake immediately and shut down the engine.

3. A first-aid kit shall be kept near you at all times, and the emergency telephone numbers of emergency center, hospital and fire department shall be available at any time. After the accident, you shall call emergency telephone of local emergency center, hospital or fire department as appropriate.

4. In order to ensure personal safety of you and others, please don't risk driving or operating. After the machine is well repaired and when the surrounding environment is safe, the operator shall restart and have it move slowly.

5. In case of fire, you shall shut down the engine immediately. Use fire extinguisher, if any, to spray towards the root of flame; if no any fire extinguisher, the sands can be used for fire fighting.

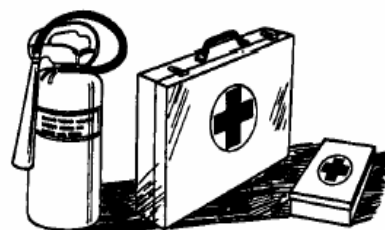

Fig. 1-10 Disposal of emergency event

Upon connecting with other devices or changing of components for tractor

1. Upon changing of components, you must shut down the engine and park the tractor onto a safe place for changing. Prior to changing, please carefully read safety sign and operation instruction, if necessary, the professional personnel shall be invited for change.

2. When the tractor is connected with other devices, the personal injury may be caused if lack of necessary experiences, therefore, the professional personnel shall be invited to execute connection if necessary.

Correct use of battery

1. The gas overflowed from the battery is dangerous, therefore, the battery shall be kept away from open fire (fire from match, lighter or cigarette, etc); the electric line shall not have a short circuit and generate spark.

2. The battery shall be used for other applications other than engine starting.

3. When the battery is charged or changed, please read the notice label on the battery.

4. When the battery is removed, please remove the bond strap that is connected with negative terminal (-) shall be removed. After battery is mounted, the cable that is connected with positive terminal (+) shall be installed firstly.

5. When the battery is charged, it shall be removed.

6. Prior to charging, please inspect whether the vent hole on the battery cover is well ventilated, with ventilated surrounding environment.

7. Properly select charging current according to rated capacity of battery.

After charging, please disconnect charging source firstly and disconnect cable from the terminal of battery to prevent that the battery is detonated by electric firing.

8 Please don't use any other batteries other than the one designated by the machine.

9. It's very dangerous to contact electrolyte (dilute sulphuric acid). If eye, skin or clothes contact with electrolyte, flush it with clean water at once; when it goes into the eye, wash it with plenty of clean water and seek medical attention. The following measures shall be taken in order to avoid damage:

- ① Wear goggles and rubber gloves;
- ② Avoid breathing smoke generated by electrolyte;
- ③ Prevent splashing or leakage of electrolyte;
- ④ Use correct parallel starting procedures.



Fig. 1-11 Use of battery



Fig. 1-12 Danger of electrolyte

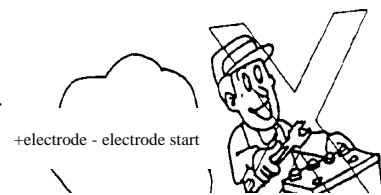

Fig.13 Inspection of battery

Maintain correct mounting of anti-rollover frame

If the anti-rollover frame is disengaged or removed due to any reason, please make sure that all the parts and components can be reinstalled correctly. Tighten the fixed bolt to the correct torque. If the structure of anti-rollover frame is damaged due to overturn accident and bending, its protection function will be influenced, so the damaged anti-rollover frame must be replaced and not be used any more.

Correct use of foldable anti-rollover frame and safety belt

1. If the tractor has a foldable anti-rollover frame, the anti-rollover frame must be kept in the fully extended and locked position. If the anti-rollover frame of tractor works when it is in folded position, carefully drive the tractor. If the anti-rollover frame is in the folded position, it's not allowed to use seat belt.
2. If the normal working conditions of tractor are recovered, the anti-rollover frame must be lifted to the fully extended position and fixed immediately. When the anti-rollover frame is in fully-extended or locked position, the safety belt must be used.
3. If the mounting fasteners, retaining ring or retractor has any damage, the whole safety belt must be replaced.
4. Inspect safety belt and its mounting fasteners frequently. Check whether the fasteners are loose or safety belt is damaged, such as incision, scratch, abnormal damage and abrasion.
5. If no anti-rollover frame or driving cab is provided, it's prohibited to use safety belt.

Cautions when installing the implement or dragging the trailer

1. When installing the dragging implement or trailer, the engine should stop and the tractor should park at the safety position. Please read implement's or trailer's installing instructions, signs and operating manuals carefully before changing.
2. The operation should be carried out according to the operating manual. Before finishing installing the dragging implement or trailer, it is forbidden to operate the tractor which is installed implement or connected trailer.
3. When connecting the dragging implement or trailer to tractor, it maybe cause personal injury if the person is lack of necessary experience. So the professional should be invited when necessary.
4. The implement should has fallen to ground before people leaving the tractor.
5. People should keep away from the areas between tractor and trailer when tractor is working with trailer.

Warning:

1. Please hold your safe operation for sake of your life, property security and family happiness.

2. When the tractor starts up, the attention should be paid to whether there is the obstacle on path, anyone present between tractor and farm tool or trailer, to prevent from the sudden start of tractor, action out of control, which will cause the accident risk;

3. Do not leave the pilot seat to start and operate the tractor. Be sure that various shift levers stay in the neutral gear position prior to the startup and the PTO control handle and drive handle on the disconnecting position, the lift operating handle put in the neutral position, to prevent from the sudden start, action out of control, which will cause the accident risk.

4. Do not start up the engine by the way of bridge-over short circuit stubs, otherwise, the tractor will automatically loose control on driving and cause the accidental danger when the gearbox is engaged.

5. The pedal action should not have any hindrance, all of pedals must be free from obstacles and able to back on home position. On the floor and under the pedal, there must not be any things hindering the treadle travel. No rolling or slip objects may lay aside when steps on the pedals. The extra foot blanket or other mats are not allowed to lay around the pedals, in order to avoid the influence on the pedal movement and cause the accidental risk

6. While the tractor is moving, persons are not allowed to get on and off. During the engine run, no check and repair operations by crawling under the bottom of the tractor are permitted for prevention from the accidental risk.

7. After parking and before getting down from the tractor, the driver must take out the key, set all shift levers on the neutral position, and lock up the auxiliary brake handle to prevent the tractor from the sudden startup, action out of control and accidental risk.

8. During the operation, the L/R brake pedals must chain-linked and the speed reasonably under control. When crossing the tunnels and the bridges, full attention must be paid to whether the load is over the limited height. The sufficient deceleration must be made in advance while turning to avoid the accident, overturn and collision.

9. On and down slop, the lowest gear must be used and the use accelerograph reasonably controlled. It is strictly prohibited for the tractor to shift on neutral gear or to glide downhill by stepping on the clutch pedal. It is strictly prohibited for the gear shift on and down slop so as to avoid the danger of overturn.

10. The sudden turn is not allowed while the tractor drives on high speed. Do not make the sudden turn by the unilateral braking, to avoid the danger of overturn.

11. By driving the tractor, the attention should be paid to the traffic indication and the traffic law and rules strictly observed, in order to avoid the accidental safety hazard.

12. In case of tractor displacement, the traffic rules should be strictly observed with at least 60mts of distance maintained between vehicles, to avoid the collision by accident.

13. The roadbeds near ditches, caves are more fragile, the tractor's weight possibly causes their crushes, please make a detour, otherwise the accidental danger may arise.

14. The tractor is not allowed to the overload and the excess use of load. It is prohibited to run over limit duty, which may cause the machine damage, even the casualty of present persons.

15. When tractor works at night, the good lighting attachment must be provided in order to avoid the influence on the tractor work efficiency and dangerous accidents.

16. When the tractor carries on the harvest or backyard work, The spark extinguish device must be fixed

on the exhaust pipe , in order to avoid the accidental fire.

17. When working on rain day, The operation rate must be reduced to prevent the path and ground from creating slippery and the danger of overturns.

18. When the operation of dynamic output is carried out, the reliable connection and protection must be guaranteed to avoid the moving parts for shaking off and injuring persons.

19. When hitching and towing the attached tools, the reliable and fast connection of pin rolls must be guaranteed to prevent them from shaking off and causing the danger of collision. When disconnecting the hitch and towing tools, be sure that all pin rolls apart and avoid the damage on the machine and human safety danger by the misconnection.

20. When lifting, be careful of the control on the engine throttle to avoid over-speed of winding, which may damage the machine or endanger the personal safety.

21. During the battery charge, Make sure that the air vent of fluid injection fills is unimpeded and far away from the open fire. After charge, the power should be first cut off to prevent from explosion.

22. The installation height allowed by the High voltage transmission line must be strictly observed, in order to avoid the dangerous accident!

23. Don't use the tractor when it has the danger to turn over in dangerous area.

24. Just when the tractor finishes working, it is necessary to prevent oil heat surface to splash when people add oil or coolant to engine or transmission.

25. When operate three-point hitch, people should keep away from the hitch working area.

26. The implement should have already fallen to the ground before disconnecting it from tractor.

27. According to the function of implement and trailer, the user can adjust PTO speed through PTO shift.

PTO speed is 540/760 or 540/1000.

28. When using PTO drive shaft, it is necessary to remove PTO shaft-end cover and make sure that protecting cover installs correctly in the working area.

Caution:

1. Bolts, nuts and easy loose components on each joint, e.g. the nuts on the front/rear drive wheels and those attaching the steering draw rod should be frequently checked. If loose, screws it tightly to avoid the dangerous accident.

2. When the tractor runs by dynamic output, the safety shield of power take-off shaft has to be installed. Persons are strictly prohibited to approach the Power take-off shaft. When the power take-off shaft is on load, the tractor is not allowed to make the sudden turn in order to avoid the damage on the universal joint or the power take-off shaft; When the Power take-off shaft is not in use, the handle should be made on separate position, to avoid the dangerous accident..

3. After parking and before shut down from the tractor, the driver must take out the key, set all gearshift levers on the neutral position, and lock up the brake handle, to prevent the tractor from the sudden startup, action out of control and accidental danger.

4. When , the hand braking handle should be in active state, let the engine shut down, put on gear (Uphill position on front gear, downhill on reverse gear position), The auxiliary brake must be used with three pieces

of triangle chocks blocking the rear wheels, to prevent from the action out of control and the accidental risk.

5.The installation and adjustment of tires can be carried out by the trained persons with special-purpose tool. The wrong installation of tires may cause the serious accident.

6.When the water tank is to be cleaned up, the engine should be first shut down and lets the water tank cool for cleaning , in order to avoid the scald accident and the damage on the water tank.

7.Before the selection for installing and replacing the parts, or for safe use by towing the machine and tool, please pay attention to the safety and carefully read the safety identifiers and the instruction for use.

Important:

1.For the tractor from the new production or after the overhaul, the running-in has to be made according to the requirements of tractor's running-in, in order to avoid the affects on the normal service life of tractor.

2.The tractor should use various kinds of solution strictly according to the request. The fuel must be subject to at least 48h(hours) sediment and purification process. Only having passed through the filtration by filter at the same precision as that of oil absorption filter of lifter, that the lubricating oil in the transmission system can be added.

3.Prior to the startup of tractor, the oil system, electric circuit and the cooling water have to be examined; After the startup, the attention has to be paid anytime to the readout of various instruments.

4.Before the power take-off shaft actuates the farm tool, the matching rationality between the tractor and driven farm should be inspected. When tillage is performed, the included angle between the power take-off shaft and the universal joint drive shaft should not be bigger than 15° (grad); When the hydraulic operating control is normal, and after the farm tool has been lifted at the curve of field edge, the included angle between the power take-off shaft and the universal joint drive shaft should not be bigger than 20° (grad); It is prohibited to dig the Rototiller into field prior to the power take-off connection, for this will cause the damage on the Rototiller and severe damage on the tractor clutch [To increase the work efficiency, the power supply can not be shut off at the time of curve, however, the lifting height of tools must maintain ca. 200mm above the ground (millimeter)].

5.The tractor is hanging the farm tool shifts when should farm tool position locking; The farm tools must be lower on the ground when the driver leaves the tractor.

6.When the temperature in winter is lower than 0°C (degree Celsius), the anti-freezing fluid must be used;

7.The front driving axle of tractor can be used only at the time of farmland work, on muddy road and skidded tires; the use on other cases is not allowed , otherwise it is easy to create the premature wear of tire and the power transmission.

8.For the tractor maintenance, the qualified spare-parts must be used;

9.During the running process of tractor, driver's foot are not allowed to place on the brake pedal or the clutch pedal, in order to avoid the premature wear of the brake or the clutch;

10. When the tractor displaces with attached farm tools, the upper lever of the suspension unit should be adjusted to the shortest condition, and the limit lever Adjusted to prevent the farm tools from swinging. At the meantime, the locking nuts of upper and limit levers must be tightly screwed in order to guarantee the travel security and avoid the damage risk on the machine and farm tools.

Twists off the radiator cap

When the Engine remains on warm state, care should be fully taken when twisting off the radiator cap. After several minutes of idle regime rotation and engine shutdown and cooling, twists the radiator cap to the first gear position, then takes it out after the pressure has been reduced .

Note: It is forbidden to put flammable and explosive objects near the oil tank orifice.

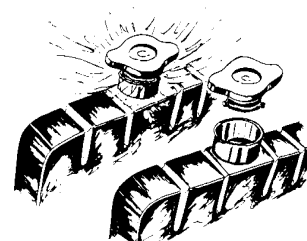

Fig. 1-14 Twists off the radiator cap

Maintenance of electric parts

1. Takes out the electrical locking switch key.
2. Only the electric appliance service can be carried out after the earth wire has been separated from the battery.
3. It is dangerous to touch electrolyte (dilute sulfuric acid).

If eyes, skin and clothes touch the electrolyte, please wash with water immediately. If the electrolyte enters into eyes, please parts

wash with a lot of water immediately and go to see a doctor.

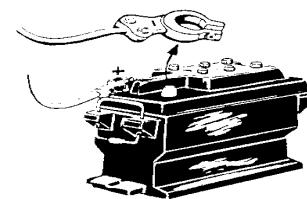

Fig. 1-15 Maintenance of electric parts

In case of abnormal phenomenon occurred on the tractor

1. The tractor is not allowed to work "in spite of defects". In particular, on lack of oil pressure, excessively low oil pressure, over-high water temperature or unusual sound and smell, stops the work in time for check-up and troubleshooting.
2. During the lubrication maintenance and adjustment on field, the engine should be shut down.



Fig. 1-16 In case of abnormal phenomenon occurred on the tractor

Upon lifting of tractor

On the lifting position on the front end.

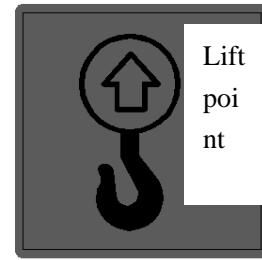

Fig.1-17 Lifting signs of whole machine

Safety rules for unattended tractor

1. Engage neutral gear and place the hydraulic operating handle to the middle position.
2. Place the lifting device or towing device onto the lowest position.
3. Apply parking brake.
4. Remove engine switch key.
5. If the vehicle is parked on a slope, its rear wheel must be blocked with triangle block.

1.2 Safety warning symbols



Caution:

1. The safety identifiers should remain clear and easy to read. When dirty, washes with soapy water and cleans them with soft rag;
2. When the safety identifiers lose or are unclear, it is necessary to contact the sales department or the manufacturer in time for replacement.
3. In case of replacing the parts with attached Safety warning symbols, the replacement of safety identifiers should be made at the meantime.
4. The safety warning identifiers, where the prompts involve to the personal safety, must be strictly complied.



Meaning: During the machine operation, please keep the distance with the thermal surface of machine, otherwise it may cause the scald accident!
Post position: outer side of damper, water tank flank.

Fig. 1-18 Safety warning identifier IX

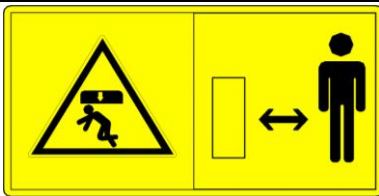

Meaning: Please keep the safe distance with the tractor, to avoid the personal injuries!
 Post position: left from the rear side of mudguard

Fig. 1-19 Safety warning identifier IX



Meaning: it is prohibited to sit on the non-crew member position in the tractor, otherwise it may cause the accident of falling from vehicle!
 Post position: front side of the mudguard .

Fig. 1-20 Safety warning identifier VI



Meaning: When the lifting lever control system works, stays far away from the effective space of lifting lever, otherwise it may cause the personal injuries!
 Post position: right from the rear side of mudguard

Fig.1-21 Safety warning identifier III



Meaning: prior to the service, maintenance and adjustment, the engine should be shut down, the key taken out, then perform according to the requirements set out in the instruction for use.

Post position: in front of the instrument panel.

Fig. 1-22 Safety warning identifier IX



Meaning: When the engine works, do not hand into the working area, and do not open or dismantle the safety hood.
 Post position: on the engine hood.

Fig. 1-23 Safety warning identifier IX



Meaning: The driver must start up the engine on the pilot seat.
 Post position: in front of the instrument panel.

Fig. 1-24 Safety startup symbol



Meaning: Please read the instruction for use, understand the meaning of the non-lettered safety symbol.
 Post position: in front of the instrument panel.

Fig. 1-25 Reads the instruction identifiers



Meaning: only fully stopped that all parts of machine can be contacted.
 Post position: on the PTO shield.

Fig. 1-26 PTO safety identifiers

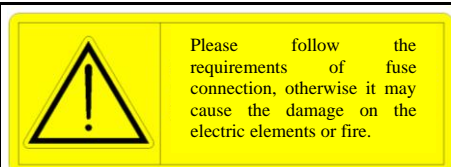

Post position: near the electric appliance box.

Fig. 1-27 Fuse safety warning symbol



Meaning: the battery is held on service, please read the instruction for use to understand the correct maintenance process.
 Post position: on the surface of the battery.

Fig. 1-28 Battery symbol

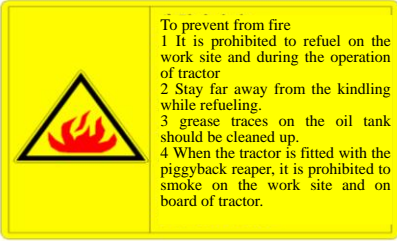

Post position: near the refueling of fuel tank

Fig. 1-29 Refueling fire protection identifiers



Post position: near PTO shaft

Fig. 1-30 PTO safety identifiers

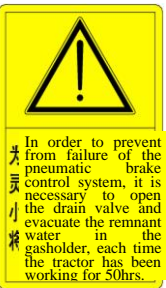

Post position: on the pneumatic brake gasholder

Fig. 1-31 Pneumatic brake warning identifiers

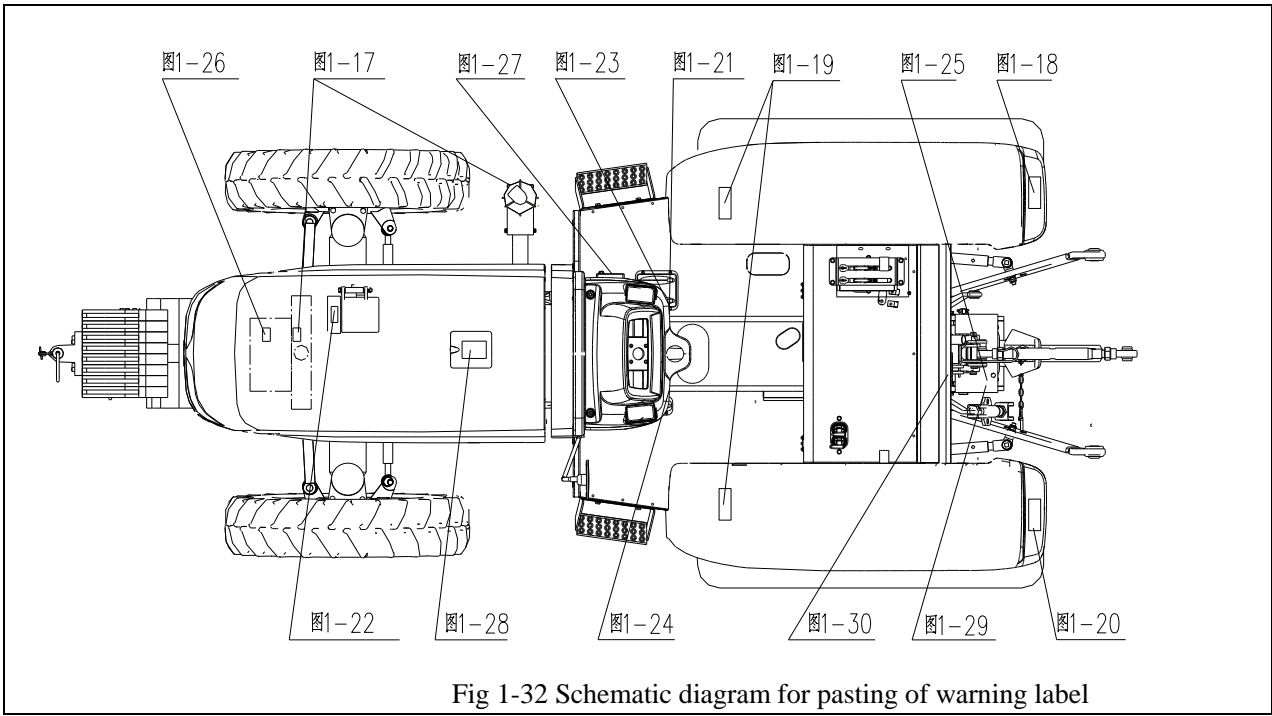

Fig 1-32 Schematic diagram for pasting of warning label

2 Products Marking

Product nameplate

The product nameplate, an important identification for the tractor, is located on the right of instrument panel. When receiving the after-sale service, the service personnel may inquire and check the nameplate, so please don't damage or lose it, and do keep its content clear.



product nameplate

Fig.2-1 product nameplate

Engine information

The nameplate of the engine, an important and valid identification for the tractor's supporting power unit, is located on the top of the engine, as shown in the figure. When receiving after-sale service, the service personnel may check the nameplate, so please don't damage or lose it, and do keep its content clear.

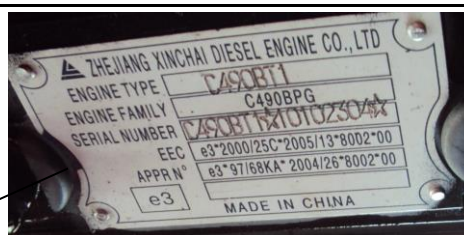

01

Fig.2-2 Engine nameplate

1



Complete type and factory No.

As the tractor leaves the factory, complete type and factory No., should be engraved or print on the three engraved and printed position



1

Fig.2-3 factory NO.

3 Operation Instructions



Note: operating the tractor properly can bring efficiency of the tractor into full play to reduce tractor wear and prevent an accident and ensure operator to complete farm and road operations fast, efficiently, in low consumption and safety mode

Table 3-1 Common symbols

Symbols	Definition	Symbols	Definition	Symbols	Definition
	Safety warning identifier		Four-wheel drive		Horn
	High beam		Dipped headlight		Quick
	Engine oil pressure		Charging and discharging indication		Slowly
	Steering light indicator		Syringe		Position lamp
	Engine preheated		Rear windscreen wiper		wiper
	Air filter blockage warning		Hydraulic oil air separator		Pneumatic braking invalid/failure
	Engine coolant temperature		Quantity of fuel oil		Parking brake
	Differential lock		Warning for danger		Warning lamp

3.1 Product description

This Instruction introduces how to use, maintain, adjust and troubleshoot SINOVOL TB series products, mainly including 40hp-80hp tractors TB404/504/604/704/804.

SINOVOL TB series of wheel tractor is a medium-sized farm wheel tractor used for paddy fields and dry soil. The farm machine tool has compact in structure, easy control, flexible steering, high lifting capacity and maintainability.

3.2 Operating mechanism and instrument of tractor

Operating mechanism diagram(Fig.3-1)

1- Instrument panel;

2- Lockplate of brake panel;

3- Left and right braking pedals;

4- Parking brake handle grip;

5- Throttle foot pedal;

6- Operating handle of hand throttle;

7- Differential lock pedal;

8- Control lever of distributor;

9- Control handle for hydraulic output(2 control handles shall be added for multiway valve type,and 1 for singleway valve type)

10- Control handle for power output

11- Control lever for front wheel drive(four-wheel drive type) ;

12- Main shift lever;

13 Assistant shift lever;

14- Clutch pedal;

15- Shuttle-type gear shift lever or creeper gear shift lever (creeper gear type or shuttle-type gear shift type)

Fig.3-1 Operating mechanism diagram

Operation mechanism for the tractor

Instrument and switch

Meters and switches of tractor (Fig. 3-2)

This model adopts combination meter and control.

The combination meter consists of water temperature gauge, fuel meter, engine speed recorder, hourmeter and fault code display screen, and the indicator light comprises turning indicator, high beam indicator, position indicator, charging indicator, oil pressure warning light and air pressure warning light.

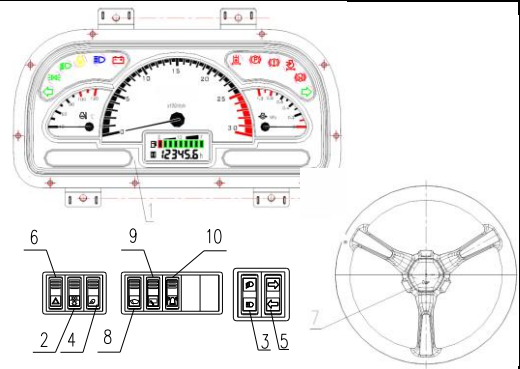

Fig. 3-2 Meters and switches of tractor

1. Combination meter assembly
2. Light switch
3. Dimmer switch
4. Working light switch
5. Reversing switch
6. Hazard warning switch
7. Horn switch
8. Front window wiper switch
9. Rear window wiper switch
10. Warning light switch

Important notes: when the tractor is operating, the driver shall always observe various instruments and indicator lights. If any abnormality occurs, it is necessary to stop and overhaul .

Engine tachometer

After the engine is started, indicated value is the operating rotary speed of the engine.

The value in the box is operating hours of the engine.

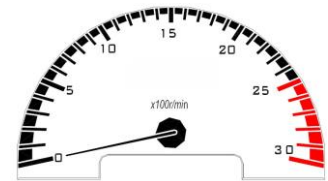

Figure 3-3 engine tachometer

Water temperature gauge

to mark the engine cooling liquid temperature, with the finger moving from left to right, and the red area is high temperature area.

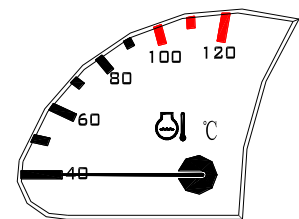

Figure 3-4 water temperature gauge

Oil gauge

Oil gauge uses the graduation to indicate the oil mount in the tank. When the finger index the most right position, it means the oil tank is full of fuel oil; when the finger index the left red area, it means the oil tank is in lack of oil, it should be fill oil immediately.

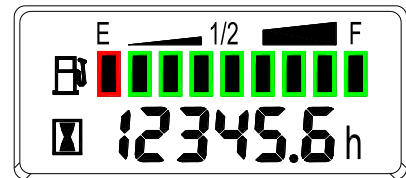
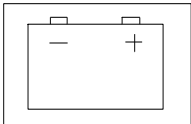

Figure 3-5 oil gauge



Charging indicator is red

Power on but unstart the engine, the lamp is illuminating; if the lamp is not illuminating, it is required to overhaul the bulb or the line is faulty. If the lamp extinguishes after the engine is started, it means that the generator generates normally. If indicator lamp is not extinguished, to check and repair the generator or voltage regulator and circuit.

Figure 3-6 charging indicator lamp

Engine oil pressure warning lamp is red.

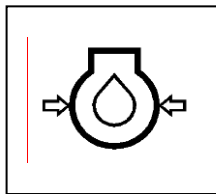

When the key is turned to the ignition position, the lamp is lit. After the engine starting, the lamp will be extinguished. It means the oil lube system pressure is normal. When the engine is idling, the light may be illuminating because it is normal that pressure in the lubrication system is low during the idling period. If the lamp is light when the engine working in normal rpm, it should be checked immediately after stop.

Figure 3-7 warning lamp for engine oil pressure

Air pressure alarm lamp (red)

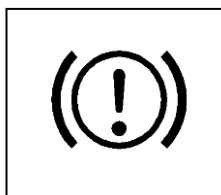

For a tractor with air brake, when the pressure of air brake system is lower than 0.45Mpa, the light is illuminating. Indicate brake pneumatic line is faulty or pressure warning device is broken. Switch on the key but unstart the engine under inflation, it is normal that the lamp is illuminating.

Figure3-8 warning lamp for air pressure

Important notes: before the engine runs, the key switches on the ignition position. Check if the above three lights are illuminating. If they are not illuminating, it is possible that bulbs are damaged or circuit faulty. Overhaul immediately.

Position indicator (green)

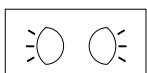

When the running tractor running on the road at night wants to park, in order to ensure the safety, and remind drivers in the front and rear running vehicle, the lamps should be turned on, to make the switch on 1 position, at this position, the lamp will be lit. At this moment, the position lights around the tractor is illuminated

Figure 3-9 position indicator

Front light high beam indicator (blue)

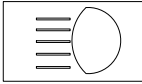

When the light switch is “2” position and the dip switch is “2” position, the light is illuminating

Indicate head light is high beam

Figure 3-10 head lamp, high beam indicator lamp

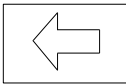

Right steering indicator (green)

When the tractor turning left, the turning left switch will be turned on and the lamp will be lit.

Figure 3-11 left-turn indicator lamp

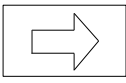

Right steering indicator (green)

When the tractor turning right, the turning right switch will be turned on and the lamp will be lit.

Figure 3-12 right-turn indicator lamp

Preheating indicator (yellow)



When the tractor is preheating, the lamp will be lit.

Figure 3-13 preheating indicator lamp

Rock switch: every operation function is as follows:

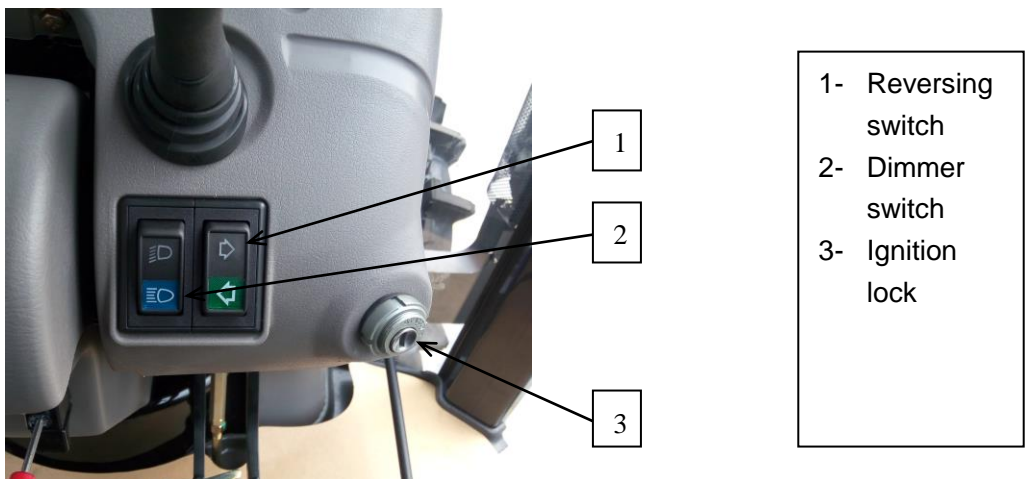

Fig. 3-14 Rocker switch (I)



Fig. 3-15 Rocker switch(II)

- 1.Rear working light switch 2 Light switch 3 Hazard warning light switch 4 Front window wiper switch 5
Rear window wiper switch



Horn switch

Horn switch is located at the center of steering wheel. To push it to activate it.

Fig. 3-16 Horn switch

Dip switch

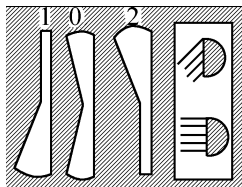

dipped headlight lit 1: spare Conversion between the high beam and dipped
headlight is controlled by light switch,
High beam lit

Figure 3-17 dimmed switch

Light switch:

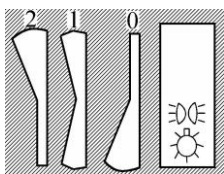

0: Cut off power 1: Outline marker lamp lights up. 2: Turn on power of headlight, and
control the conversion between high beam and low beam by the available dimmer switch.

Fig. 3-18 Light switch

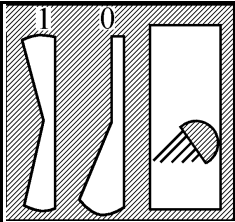

Rear working light switch

0: Cut off power 1: Rear lamp lights up.

Fig. 3-19 Rear working light switch

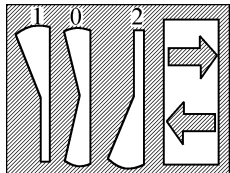

Steering switch

shut off power supply Turn on left steering lamp

Power on right steering light

Figure 3-20 steering switch

Warning switch for danger

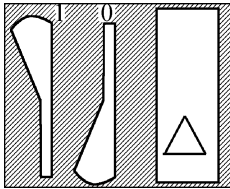

shut off power supply Front/rear and left/right steering lamps, left/right steering lamps on instrument and indicator on danger alarming switch are lit. When the tractor stops on the road because of fault or other reasons, it is required to warn other vehicles and passengers about it to avoid any incident. Now this function is used.

Figure 3-21 safety warning switch

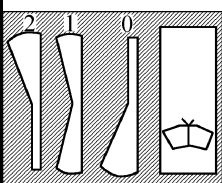

Front window wiper switch

“2”: the wiper works at rapid gear; “1”: the wiper works at slow gear; “0”: the wiper is reset and out of service.

Fig.3-22 Front window wiper switch

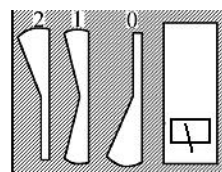

Rear window wiper switch

“2”: the wiper works at rapid gear; “1”: the wiper works at slow gear; “0”: the wiper is reset and out of service.

Fig.3-23 Rear window wiper switch

Ignition lock

Put the key into the ignition lock and turn it clockwise to the following positions:

- Turn it to OFF gear (turn-off gear), and switch off the power of the vehicle circuitry, then the key can be inserted or removed;
- Turn it to ACC gear (auxiliary gear) to switch on the power of auxiliary electrical components (such as heater, wiper, fan and horn switch, etc), then the line of auxiliary electrical components is powered.
- Turn it to ON gear (ignition gear) to switch on the power of the vehicle circuitry, then the vehicle circuitry and ECU are powered;
- Turn it to ST gear (starting gear) to start engine; after the engine is started, release the hand immediately, then the key will return to ON gear automatically, at this time, ON gear and ACC gear are engaged simultaneously and the power of the vehicle circuitry is switched on.

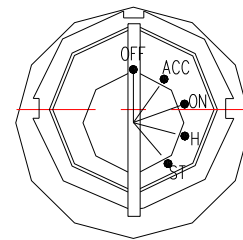

Figure 3-24 Ignition lock

3.3 How to start engine

Important notes

1. Before using, carefully and completely check the tractor will eliminate potential accident and efficiently avoid faults.
2. Not allowable for other substitute as will. Clean contaminant in water tank screen regularly to avoid engine accident by improper heat radiation.
3. When the tractor is mounted with the knapsack type harvester, the heat emission condition for working in field is worse. In order to make the engine to continuous work for a long time, it is suggested to mount a auxiliary heat emission device on suitable position of the tractor.

Preparations before the engine is started

1. Before starting, it should be carefully checked, to ensure that each part is fixed tightly and stable, each operation mechanism function is normal, each pipe joint is fastened, and there is no oil/water/air leakage.
2. Check oil pan of the engine, tractor gearbox, rear axle and lube oil level of hydraulic system. Radiator shall be filled with cooling water. Fuel tank shall be filled with fuel.
3. Check control lever of gearbox and power output shaft control handle. Main shift lever, power output control handle and front drive axle control handle are set in neutral position. Distributor control lever is set in the lowering position.
4. For the tractor which is new, overhauled or not in use for a long time, before starting, first discharge the air in oil line to ensure that diesel engine can start smoothly. The procedure as follows: first release the exhaust screw of diesel filter, then discharge the air in the oil line from oil tank to diesel filter by hand pump until there is no bubble in the discharged oil. Then, unfasten the exhaust screw of the fuel pump to exhaust air in the same method until no air bubble not included in the flow oil.
5. Handle oil throttle is in semi-on status

Start the electromotor



Warning: before the engine is started, main and auxiliary gear shift levers, and front drive control lever are in the neutral position and distributor control lever is in the lowering position to prevent the tractor from being started suddenly and getting out of control to cause an accident)

Important notes

1. After the engine is started, release it immediately. The key returns to “ON” gear automatically. Otherwise, started engine will make actuating motor run reversely so as to damage the actuating motor.
2. Continuous starting time cannot exceed 5s each time. The starting interval shall not be less than 15s, in order to maintain charging performance of the accumulator, continuous times cannot exceed three times. If the starting fails for continuous three times, it should be stopped to troubleshoot.
3. It is prohibited to start the engine when the water tank is in lack of water or oil pan is in lack of oil, so that to avoid serious fault.
4. After the engine is started, the throttle is eased up but the engine speed is increasing sharply. In order to prevent the engine from being damaged seriously, emergency actions shall be taken to switch off the engine. The procedure is to release the screwed nut on the high-pressure oil line from the oil pump to the oil nozzle and pull out the oil pipeline and shut off the pipeline or block the air inlet of air filter, shut off air intake of the engine.

When starting at ambient temperature { above -5°C }:

First step main clutch pedal, then turn the key to “ON” position clockwise, and switch on. Release hand immediately after turning the key to ST position to start the starter, the key will automatically return ON position.

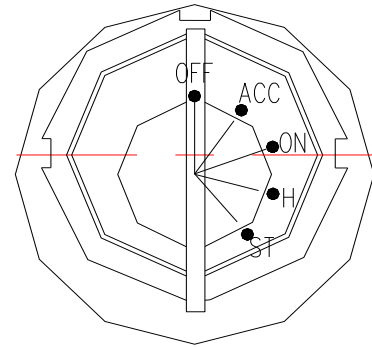

Start at low temperature [below -5°C]

When starting in low temperature (lower than -5°C), it can apply preheating starting. To put handle oil throttle to ACCELERATION position, turn the key clockwise to preheating shift H position and stick for 1.5 ~20 seconds then turn to start shift ST position to start the starter. Release it immediately after starting, the key returns to “ON” automatically.

Starting in winter:

If it can not be started up in above way(s), do as following: discharge machine oil in bottom housing, fill in after being heated to $80\sim 90^{\circ}\text{C}$. When heating, it's necessary to stir evenly at any moment to prevent machine oil from spoiling due to being heated locally. $80\sim 90^{\circ}\text{C}$ hot water is filled into the cooling system until the temperature of discharged water reach 40°C . Then start according to low temperature starting steps.

Engine running

After the engine is started, the throttle shall be eased up immediately. Check the engine oil pressure at this moment to ensure engine oil is not lower than 9kPa. Now the oil pressure indicator extinguishes.

1. After the engine is started, full-load running shall not be made immediately. It is necessary to run the engine idly at medium speed to preheat. When coolant temperature is above 60°C , it is allowed to increase to the highest speed and operate at full load.
2. The engine rotary speed and load should be slowly increased or decreased, especially for a newly starting engine; it is not allowed to run at high speed by sudden turning the handle oil throttle.
3. During the running of the engine, engine oil pressure and coolant temperature shall be checked normally. During the normal operations of the engine, the cooling temperature is $85\sim 90^{\circ}\text{C}$, engine oil pressure is $294\sim 49\text{kPa}$.

Tow starting

When it's started by use of pull tractor, the pulled tractor shall use high 3rd gear or high 4th gear. For sake of safety, the speed of pull tractor shall be not more than 15km/h.

Important notes: engine oil pressure shall not be less than 9kPa under any circumstances In order to avoid engine damage, it should be troubleshoot in time.

Operation of engine

After the engine is started, it's required to decrease throttle immediately to keep the engine at idle speed, and inspect the oil pressure of engine at this time to ensure that it is not less than 98kPa, at this time, the oil pressure warning light of engine goes off.

4. After starting, the engine is not suitable for full load operation and shall be subject to no-load operation and heating at a moderate speed.
5. Increase and decrease the speed and load of engine slowly, especially for the engine which is started initially, it's not allowed to push the accelerator hard for high speed operation.
6. When the engine is working, it's required to inspect the oil pressure of engine and the temperature of cooling liquid frequently. During normal operation of engine, the cooling temperature is generally between 85 and 95°C, and the oil pressure shall be between 294 and 490 k/Pa.

Important notes: in no case the oil pressure of engine shall be less than 98kPa. In order to avoid damage of engine, please execute troubleshooting in time.

3.4 How to start tractor

1. The engine is at the low speed. Step on the clutch pedal to disengage main clutch and then turn the shifting lever of gearbox to the required shift.
2. pull the braking handle downward, release parking brake and test the braking performance of the tractor to ensure the braking is reliable and with no fault. After that, the tractor can run.
3. Press horn and observe around for barrier
4. Gradually increase engine rotary speed step gradually and release clutch pedal to have the tractor started stably. Release clutch pedal immediately after starting to avoid clutch slipping
5. Step on the gas gradually to make the tractor run at required speed.
6. During using, it is not allowed to use clutch semi-engagement to lower the tractor speed. During running, it is not allowed to put food always on the clutch pedal, so that to avoid accelerating the releasing rod and



Figure3-26

friction disc wear.

Important notes

1. To prevent “Tooth Breakage” of drive gear of gearbox or earlier clutch damage, Shift High Start is forbidden.
2. Release the brake before starting to avoid damaging operating parts.
3. When putting into gear or gear shifting, the clutch pedal shall be stepped on to disengage main clutch to prevent drive gear tooth of gearbox from being broken or prevent the clutch from being damaged early.
4. When starting by the traction tractor, once the engine is running, step on main clutch pedal immediately and throttle down to prevent the engine kill.

3.5 How to steer tractor

When tractor steers on road, press the speaker switch on the steering wheel to signal alarm, and finally, make steering. If the speed is too high, it should be firstly lower the speed, slowly steer and early turn, little steer and little return. If steering angle is large, it should be slowly steer and early turn, more steer and more return.

When tractor turns a small angle or turns on a spongy-soft soil, steering is not flexible due to side slip of front wheel, therefore, it's possible to step on brake pedal on corresponding side while steering wheel is rotated to help steering.

Important notes

1. When front wheel turns sharply, if the safety valve sneaks during the course of acting, steering wheel shall retract a little to prevent the machine from being damaged because the hydraulic steering system is overloaded for a long time.
2. Before making turns or backing during working in field, the farm machine part entered into the soil should be lifted out of the ground, so that to avoid farm machine damage.

3.6 How to gear shift tractor

Schematic diagram for combination of various gears of TB-1 series tractor (Fig. 3-28)

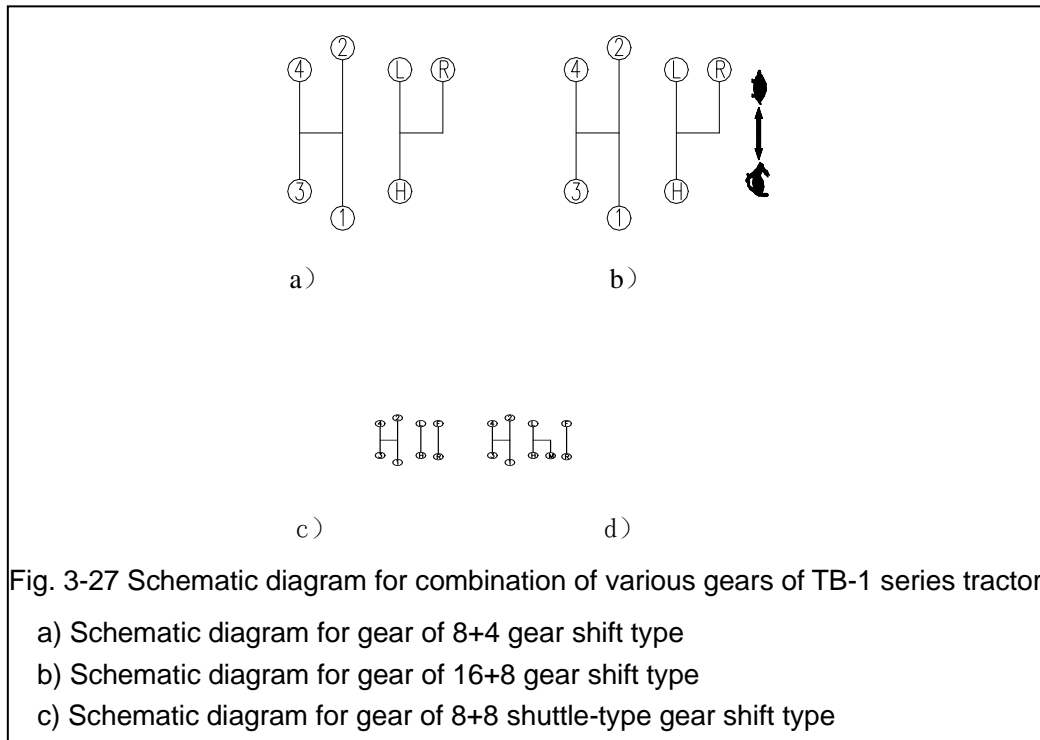

- 8+4 gears (namely a) shown in Fig.3-27)

8+4 gears are controlled by 2 control levers. 4 gears (1,2,3,4) can be available through main gear shift lever, and 2 forward speed zones (L indicates low speed zone, H indicates high speed zone) and 1 reversing zone R can be available through auxiliary gear shift lever B.

Depress main clutch pedal, and move the main gear shift lever A to the right from neutral position and then push it backwards to engage 1st gear, and if you push it forwards, the 2nd gear will be engaged; move it to the left from the neutral position and push it backwards to engage 3rd gear, and if you push it forwards, the 4th gear will be engaged.

Depress main clutch pedal, and push the auxiliary gear shift lever B to the left from neutral position and then push it forwards to engage the low gear L, and if you push it backwards, the high gear H will be engaged; push it to the left from neutral position and then push it forwards to engage the reversing gear R.

- 16+8 creeper gears (namely b) shown in Fig.3-27)

16+8 gears are controlled by 3 control levers. 4 gears (1,2,3,4) can be available through main gear shift lever, and 2 forward speed zones (L indicates low speed zone, H indicates high speed zone) and 1 reversing zone R can be available through auxiliary gear shift lever B. The creeper gear zone and normal speed zone can be available through creeper gear shift lever.

Depress main clutch pedal, and move the main gear shift lever A to the right from neutral position and then push it backwards to engage 1st gear, and if you push it forwards, the 2nd gear will be engaged; move it to the left from the neutral position and push it backwards to engage 3rd gear, and if you push it forwards, the 4th gear will be engaged.

Depress main clutch pedal, and push the auxiliary gear shift lever B to the left from neutral position and then push it forwards to engage the low gear L, and if you push it backwards, the high gear H will be engaged; push it to the left from neutral position and then push it forwards to engage the reversing gear R.

The creeper gear shift lever is provided on the right side of floor. Push the control lever forwards from neutral position to engage creeper gear zone, push it backwards to engage normal speed zone, if it's grouped with the above-mentioned main gear shift lever, 16 forward gears and 8 reversing gears can be available.

- 8+8 shuttle-type gear shift (namely c) shown in Fig.3-27)

8+8 gears are controlled by 3 control levers. 4 gears (1,2,3,4) can be available through main gear shift lever, and 2 forward speed zones (L indicates low speed zone, H indicates high speed zone) and 1 reversing zone R can be available through auxiliary gear shift lever B. The creeper gear zone and normal speed zone can be available through creeper gear shift lever.

Depress main clutch pedal, and move the main gear shift lever A to the right from neutral position and then push it backwards to engage 1st gear, and if you push it forwards, the 2nd gear will be engaged; move it to the left from the neutral position and push it backwards to engage 3rd gear, and if you push it forwards, the 4th gear will be engaged.

Depress main clutch pedal, and push the auxiliary gear shift lever B to the left from neutral position and then push it forwards to engage the low gear L, and if you push it backwards, the high gear H will be engaged.

The shuttle-type gear shift lever is provided on the right side of floor. Push the shift lever forwards from neutral position to engage forward gear, and push it backwards to engage reversing gear.

- 12+12 shuttle-type gear shift (namely d) shown in Fig.3-27)

12+12 gears are controlled by 3 control levers. 4 gears (1,2,3,4) can be available through main gear shift lever, and 3 speed zones (L indicates low speed zone, M indicates moderate speed zone and H indicates high speed zone) and 1 reversing zone R can be available through auxiliary gear shift lever B. The forward and reversing gears can be available through shuttle-type gear shift lever.

Depress main clutch pedal, and push the main gear shift lever A to the right from neutral position and then push it forwards to engage 1st gear, and if you push it forwards, the 2nd gear will be engaged; move it left from neutral position and push it backwards to engage 3rd gear, if you push it forwards, the 4th gear will be engaged.

Depress main clutch pedal, and push the auxiliary gear shift lever B to the left from neutral position and

then push it forwards to engage the low gear L, and if you push it backwards, the high gear H will be engaged; push it to the right from neutral position and push it backwards to engage middle gear M.

The shuttle-type gear shift lever is provided on the right side of floor. Push the shift lever forwards from neutral position to engage forward gear, and push it backwards to engage reversing gear.

Correct selection of working speed of tractor can not only obtain optimal productivity and economical efficiency, but also increase its service life. When the tractor is working, it shall not bear overload frequently, and the engine shall have a certain power reserve. The selected working speed of tractor in field shall make the engine bear about 80% given load. When the tractor works under light load and at a low speed, the high 1st gear can be selected to save fuel. The selection of theoretical speed of various gears of tractor is shown in Table 8-4 and 8-5.

Important notes

1. During the running of the engine, step on clutch pedal to disengage the main clutch. In several seconds, gear shift to avoid “tooth breaking”
2. Shift Backward can not be engaged until tractor is at rest to avoid gear from being damaged.
3. When tractor is running, never place your hand(s) on gear shift lever, otherwise, the pressure on your hand(s) can be transmitted to gear shift fork in gearbox by which causes the fork to be worn early

3.7 How to operate differential lock

During running or working, if the tractor can not move forward when it falls in pit or single-drive slips, it can turn on the differential lock as following sequences, to rigid connect the left and right drive shaft.

1. Step on main clutch pedal, operate gear shift lever and engage low shift
2. Push the throttle control handle to the maximum supply position
3. Step on differential pedal
4. Release the clutch pedal smoothly to operate the tractor stably
5. After running out of the skidding section, to release the differential pedal, the differential lock will automatically release.



Figure3-28

Important notes: when the tractor drives normally and turns, it is forbidden to use differential lock to avoid damaging components and accelerate tyre wear.

3.8 How to use front drive axle

When working in the field with heavy load or on humid and soft soil, if only driven by rear wheel, the four-wheel drive tractor will in lack of traction ability. If mounted with the front drive axle, it can improve the traction ability and lower the skidding, so that to improve the tractor operation flexibility. In order to engage and release the front axle, the following operation sequence should be followed:



Figure 3-29

1. Step on main clutch pedal and engage the gearbox shift, then release clutch pedal slowly. After the tractor moves a little, pull up front drive axle control handle backward immediately and change two-wheel drive into four-wheel drive.
2. Before parking or shifting, to step e the main clutch pedal, firstly push the front axle handle forward to release the front axle, then take off the shift or put on required shift.

Important notes

1. The tractor will run out of the slip area with th When the tractor transports on the hard road, it is not allowed to connect front drive axle. Otherwise, it will result in early wear for front wheel and oil consumption increase. Only in rainy or snowy days, which road is comparatively slip and it is easy to slip when climbing the large slope, the front axle can be connected. When the tractor gets out of adverse circumstances, front drive axle shall be disengaged.
2. When tractor performs a transportation operation, front wheel tyres wear rapidly and left/right sides of tyre tread patterns are worn unevenly, therefore, it's possible to exchange the left/right tyres.

3.9 How to brake tractor

1. Usually, minish oil throttle, step on clutch pedal, and then gradually step on the brake pedal to park the tractor stably.
2. At emergency, step on the clutch and brake pedal simultaneously. It is forbidden to step on brake pedal separately to prevent the brake friction disk from being worn sharply or avoid the engine kill.
3. When tractor runs on road, lock both left/right brake pedals together with a lock plate.



Fig. 3-30



Warning: when driving on the road, left and right brake pedals shall be interlocked to prevent the tractor from running out of the line or turning over.

3.10 How to stop tractor and how to flameout engine

1. Throttle down to decrease the tractor running speed
2. Step on the clutch pedal as well as brake pedal, lock braking handle. When the tractor stops, shifting lever shall be set at the neutral gear.
3. Release clutch/brake pedal, and reduce the oil throttle to make the engine run idly.
4. Pull backward flameout bar by which oil pump stops supplying oil and engine flame goes out. Afterwards, push it back to its oil supplying position.
5. Turn starting switch key to “OFF” position, shut off all power supply



Note:

1. After parking, the driver can not leave the tractor before engine flame out, in order to avoid sudden starting or loosing controlled action, which will cause accidental danger.
2. If the tractor has to be parked on the slope, the gears shall be engaged (Shift Forward engaged on the uphill and Shift Reverse engaged on the downhill to prevent the tractor from being started suddenly and getting out of control which causes an accident)

Important notes

1. In winter, when the temperature is below 0°C, for the tractor without anti freezing solution, drain valve of water tank shall be opened during the run idle of the engine until the cooling water is discharged completely. Then switch off the motor to avoid damage caused by cooling water frozen.
2. To illuminate all switch during running at night Because water outlet position in water tank is higher than water inlet position of water pump, after water discharge in winter, to prevent water pipe from being frozen by water reserved in outlet pipe of water tank, it's recommended that customer opens water discharge switch after stop, set flameout handle to flameout position, and run engine for 2~3 times dragged by accumulator, 15 seconds for every 2 minutes for the purpose of drain water in water pipe empty

3.11 Adjustment of wheel tread

3.11.1 Adjustment of front wheel tread

- Adjustment of front wheel tread of two wheel drive tractor: lift the front and rear axles of tractor by jack, remove locking bolts 2 and 3 of main and auxiliary casing on the left and right, the remove locking bolt 4 and cylinder retaining bolt 1, adjust the position of auxiliary casing and cylinder and adjust the length of tie rod as appropriate, finally reinstall and tighten the removed bolts. When front wheel tread is adjusted, 4 wheel treads can be available: 1150mm,1250mm,1350mm,1450mm.

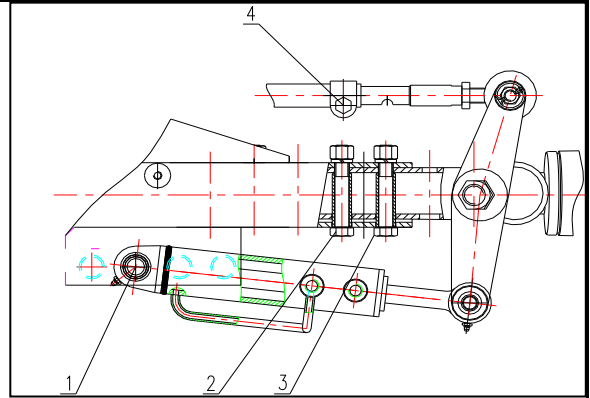

Fig 3-31 Front axle of tractor

- The front tyre rim of four wheel drive tractor is welded together with the center plate, so the wheel tread is not adjustable. The front wheel tread is 1250mm for the machine type with common ground clearance, and 1450mm for the machine type with higher ground clearance by big wheel.

3.11.2 Adjustment of rear wheel tread (for non-stepless adjustable wheel tread type)

- The common wheel tread of the machine type with common ground clearance is 1300mm, and 4 wheel treads can be available through different connecting positions of center plate and tyre rim, as shown in Fig.3-33.
- The common wheel tread of the machine type with higher ground clearance by big wheel is 1408mm, and 4 wheel treads can be available through different connecting positions of center plate and tyre rim : 1312 mm,1376 mm,1408 mm,1496 mm.

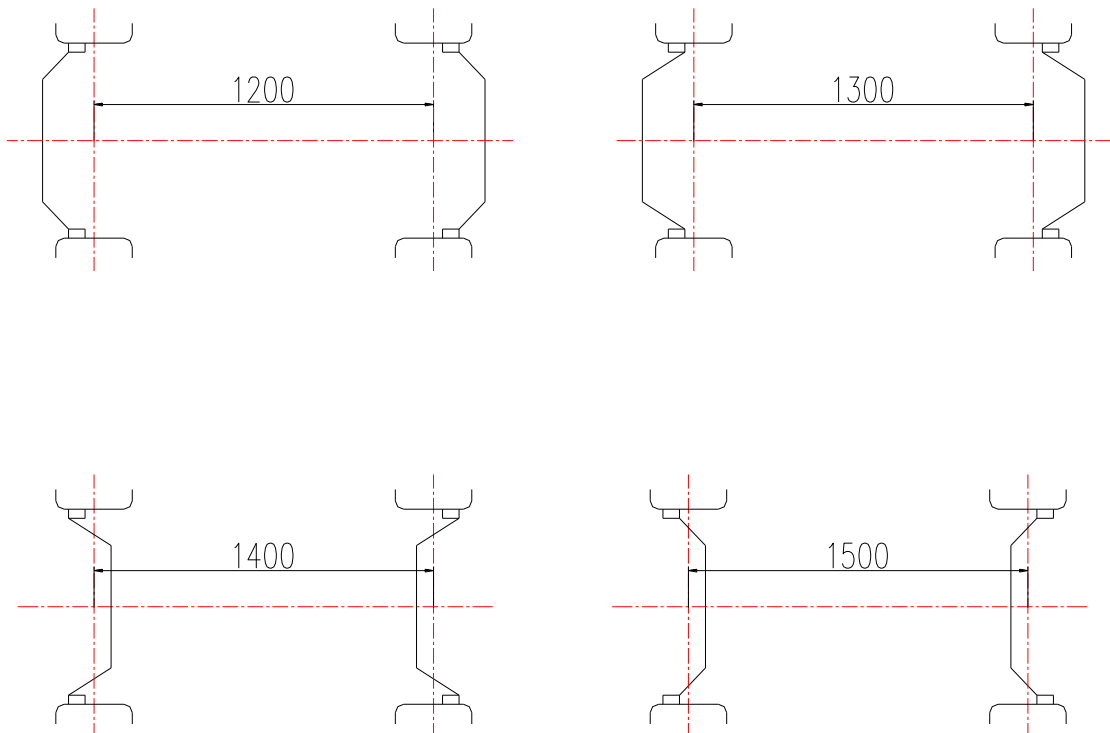

Fig.3-32 Adjustment of rear wheel tread of tractor (unit:mm)

3.11.3 Adjustment of rear wheel tread (for stepless adjustable wheel tread type)

The common ground clearance machine type is stepless adjustable wheel tread machine type, and the common wheel tread is 1300mm. 1200-1500mm stepless adjustment can be realized through different connecting positions of center plate, wheel hub and rim.

The common wheel tread of the machine type with higher ground clearance by big wheel is 1408mm, and 1300-1500mm stepless adjustment can be realized through different connecting positions of center plate, wheel hub and rim.

3.11 How to use and assemble/disassemble tyre

Use of tyre

Tyre is the consumable of tractor. More attention shall be paid to usage and maintenance to prolong its service life.

The tyre has specified loading value. If overloaded, the tyre is deformed excessively; the side is bent excessively, which is easy to break off. Adhesive for the woven fabric in the tyre and buffer layer is easy to come apart. The woven fabric layer is loose until the tyre is broken. Especially on the uneven or affected by the impact of obstructions, it is much easier to break.

Tyre inflation pressure shall conform to the specified value. If it is too high or low, it can affect service life. If the pressure is too low, it can deform the tyre to wear the surface, even damage inner tube and out tyre. Air valve is cut off, which increases driving resistance. If the air pressure of front wheel tyre is too low, the operation will be arduous; if too high, the tyre fabric will be excessively drawn and broken, and the tyre wear will increase and the tractor vibration will increase. The tyre pressure for working in the field should be suitably low, and the tyre pressure for long-term transportation on road should be suitably high. Pressure in the tyre shall be measured by pressure gauge in ambient temperature. The measurement after the operation is not proper because of tyre heating. Improper operation for driving can wear or damage the tyres early. During running, the tractor should avoid going over obstacle at high speed, emergency stop or steering. When running on broken-stone road, the tyre slip should be avoided as little as possible. During using, the tyres should be prevented from adhering any oil, acid or alkaline chemical corrosive, or explosion under burning sun as little as possible, in order to avoid rubber aging and degraded. Front wheel alignment and toe-in should be regularly checked for correctness, in order to avoid tyre partial worn. When the patterns on the tyre are worn nonuniformly, left and right tyres can be exchanged.

Important notes: inflation pressure for front and rear tyres of 4-wheel drive tractor shall be the same to prevent the tyres from being worn.

Disassembly and assembly for tyre

How to dismantle tyre

When assembling and disassembling, special tools shall be used. Sharp tools are forbidden. For example, sledge hammer cannot be used to strike at random to avoid the tyre from being pierced or the edge and the rim from being damaged

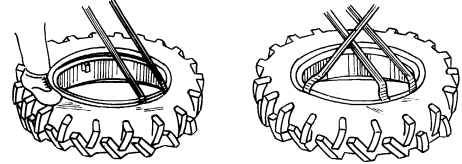

Figure 3-33 Tyre dismantling

When removing the tyres, first discharge and then press the edges on both sides of outer tyre into the groove of the rims. Then a crowbar is used to pry the tyre edge on one side out of the rim near the air valve and two crowbars are used to pry the whole tyre edge out of the rim by turns. After taking off inner tube, prize open the wheel rim on the other side in the same way and take off outer tyre.

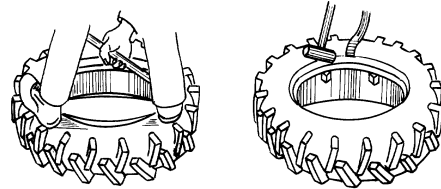

Figure 3-34 tie mounting

How to mount tyre

When mounting tyre, check whether wheel rim and tyre for engagement, the rim is de-burred or no serious deformation, clean iron rust on the rim and check tyre for break or damage. After parts and components have been cleaned when mounting, a thin layer of talcum powder between inner tube and outer tyre Place wheel rim in level, assemble its outer tyre, and prize into wheel rim by foot or stick Put into the tyre tube (outer tyre can be underlaid a little). Air valve is fastened in the hole of the tyre rim by lead wire to prevent it from slipping Pry the other side of outer tyre into the rim by a crowbar. It is the most difficult to pry the last segment. It is possible to use a hand hammer to strike the crowbar lightly. Finally, check air valve position for OK and wheel rim and wheel for tight joint. When inflating, recheck if the tyre tube leaks or not. Inflating as well as striking the outer tyre manually shall be made at the same time. It is better to discharge half of the air after reaching the specified pressure and then refill so that tyre tube can expand normally and crimping can be eliminated. When installing the tyre, the direction of tyre pattern shall be correct. Otherwise, it will affect adhesive performance and wear resistance, and deposit the mud.



Warning: it is forbidden to remove the connection screws of the tyre, drive wheel hub and rim during the inflation. Otherwise, the wheel may fly out to cause personal injury.

3.12 How to use counter weight

3.12.1 Rear counterweight

When the tractor working in the field, in order to improve the tractor work ability, and improve the traction force, cast-iron counterweight usually is mounted on rear wheel discs.

Weight of casting iron counterweight is 30kg, 3, 5 and 6 pieces can be mounted on the single side.



Figure 3-35
counterweight application



Warning: before removing the rear wheel with rear counterweight from the tractor, first remove the counterweight to avoid unstable risk.

3.12.2 Front counterweight

In order to adjust the relation between front and rear weight of the tractor, it is necessary to mount front counterweight in the front of the tractor.

Mass of the front counterweight frame, 45kg

The tractor can select maximum 8 pieces cast-iron front counterweights, each one is of 18kg weight.



Figure 3-36
front counterweight

3.13 How to adjust driver's seat

1. The longitudinal position of the driver seat of the TB Series Tractors can be adjusted. During the adjustment, wrench the adjustment handle at the left bottom of the driver seat outwards (as shown in Figure 3-13). At the same time, move the driver seat forward or backward. When the required position is reached, release the adjustment handle.

2. Adjust rigidity adjusting handle, according to driver's height and weight, to make driver more comfortable.

3. According to the height of driver, adjust height adjusting handle to make driver more comfortable.

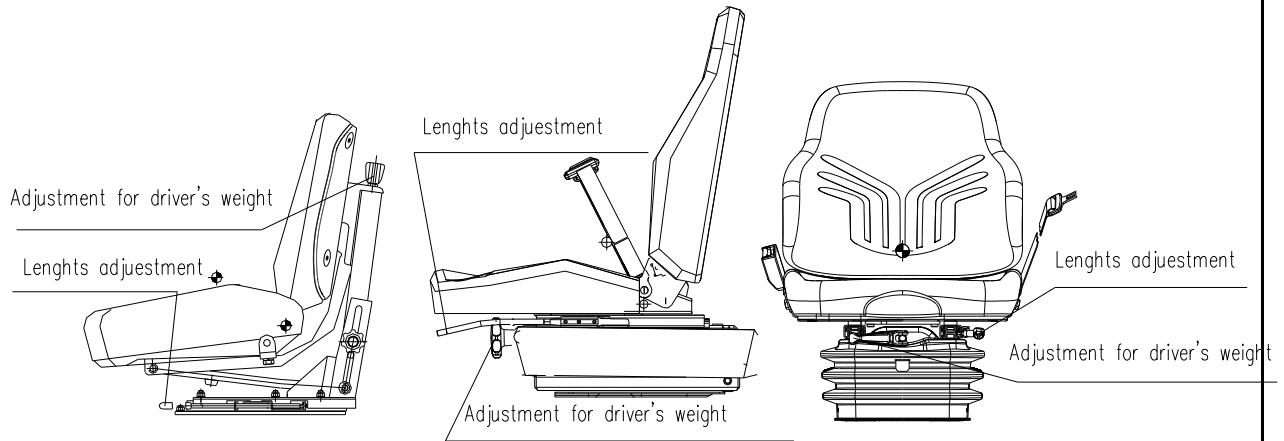

Figure 3-37 Adjustment of Driver Seat



Note:

For safety, seat can not be adjusted until tractor is at rest to avoid accident.

Rigidity of seat is not adjusted too soft, pay special attention to this point when running on an uneven road to avoid accident.

3.14 Tractor covers

Outer parts of tractor main include hood, cab (ROPS), mud guard, instrument panel, floor, accessories and so on.

3.14.1 Hood

The engine hood of the tractor adopts beautiful streamline metal plate structure. Pull the hood lock opening handle which is on the left of hood lower hoardings to open the hood lock. Then the hood opens automatically driven by the gas spring. Pull the hood downward, the hood lock will lock automatically when the hood falls to a certain level.



Figure 3-38 1
1、 cover open handle

3.14.2 Instrument panel

The electric control switch and combined instrument of the tractor are installed on the instrument panel. The instrument panel plays the role of control switch support, decoration and sealing.

3.14.3 Cab (optional)

The tractor cab is composed of frame and glass. The frame is welded by tubules profiled bar, and then inlayed space curved glass.

3.14.4 Doors

The doors is constructed by profiles of frame and is installed with a full bent glass, so it's integrated into the entire stream-line driving cab perfectly. It not only shows the spacious and comfortable driving space, but also improves the aesthetic property of the entire vehicle greatly. If you want to open the door, just turn the key of door clockwise for 90° and remove the key, hold the door handle with hand and use thumb to push the compression member 2 inwards to open the door lock, meanwhile pull the handle outwards to open door. If you want to close the door, just carry out reverse operation.

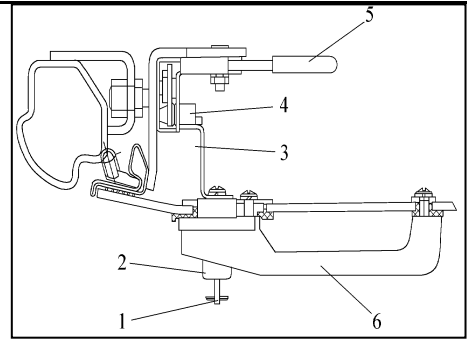

Fig. 3-39 Door lock of driving cab

1. Door key 2 Door lock 3. Push rod
4. Locking plate 5 Unlocking handle
6 Door handle

3.14.5 Rear window

The rear window of tractor is of semi-automatic bottom-hinged type, and the opening state is classified as usual state and max. state.

1. Usual state: rotate the handle, and push it outwards after the raised part on the front of the handle slides out of the slot, and after the raised part on the rear of the handle reaches the slot position, rotate the handle again to make the raised part on the rear of the handle slide into the slot to open the rear window and keep a certain angle. To close it, just execute reverse operation.

2. Max. state: place the handle, and push it outwards after the raised part on the front of the handle slides out of the slot, after the pulling force of gas spring is overcome, the gas spring will be converted into "push" state from "pull" state, then the rear window will be opened automatically. To close it, just pull the handle inwards, and after the pulling force of gas spring is overcome, the gas spring will be converted into "pull" state from "push" state, then the rear window will be closed automatically, and then rotate the handle again and make the raised part on the front of handle slide into the slot and go into locking state.

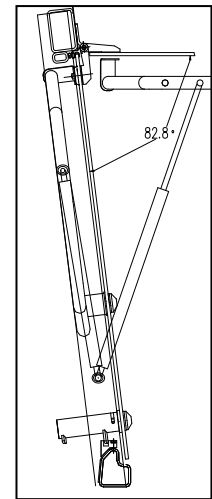

Fig.3-41 Rear window

3.14.6 Heating and cooling air conditioning in the cab (optional)

The air conditioning has heating and cooling functions. There are two air conditioning vents in the cab interior. You can switch vent cover to adjust air flow and its direction. The air conditioning left is the control panel. It has the following control methods:



Picture 3-42 air conditioning

3.14.6.1 Separate ventilation control

- Turn off the water inlet and outlet of heaters on the engine.
- Turn the wind speed switch which is in the middle of the control panel to adjust wind speed ,and then to get natural wind.

3.14.6.2 Air conditioning Control

- Turn off the water inlet and outlet of the heaters on the engine.
- Open the compressor switch which is on the left side of control panel to
- make the refrigerant compressor work. You can use cold wind of the air conditioning to reduce temperature of the cab.



Turn air conditioning temperature control switch which is on the right of the control panel to adjust temperature.

Picture 3-43Air conditioning control panel

- Turn the wind switch which is in the middle of the control panel to adjust wind speed.

3.14.6.3 Heat wind control

- Control compressor switch which is on the left side of the control panel.
- Open the water inlet and outlet switch of the heaters on the engine. Heat water begin to cycle to the heater. You can use heat wind of the air conditioning to increase temperature of the cab.
- Turn the wind switch which is in the middle of the control panel to adjust wind speed.

3.14.7 Roll bar

- Tractor roll bar is the frame which is welded by rectangular tubular material. The roll bar can turn backwards and then fold.
- It can match mid-mounted roll bar. The roll bar can turn forward and then fold.

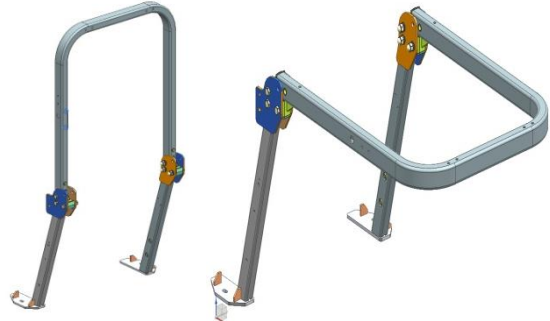

Picture 3-44 Roll bar

A- Normal use condition B- foldable condition

3.15 Use of working device of tractor

This tractor series is mainly composed of the following working devices:(optional for some devices)

- Hydraulic lifter: the force-position combined adjustment shall be preferred when plowing operation is added so as to ensure operation effect;
- Simple hydraulic output: mainly applies to hydraulic lorry.etc.
- Hydraulic output device: mainly applies to hydraulic reversing plough and hydraulic rake, etc.
- Suspension mechanism: is mainly used to connect with the attached farm implement;
- Power take-off: mainly applies to agricultural implements which need power output;
- Pendulum type traction device: mainly applies to the machine which needs harrowing, the hay mower and trail-behind planter, etc;
- Traction frame: mainly applies to two axle trailer and single axle trailer, etc.

Choose agricultural implements which are matched with tractor

Important notes: choose agricultural implements whose power is matched with the tractor. If the power of the tractor is too big, the agricultural implements may be damaged, and if the power of agricultural implements is too big, the tractor may be damaged.(Prior to connecting with agricultural implements, please refer to the manuals of agricultural implements and find the max. and min. power of agricultural implements to make their power is matched with the tractor.)

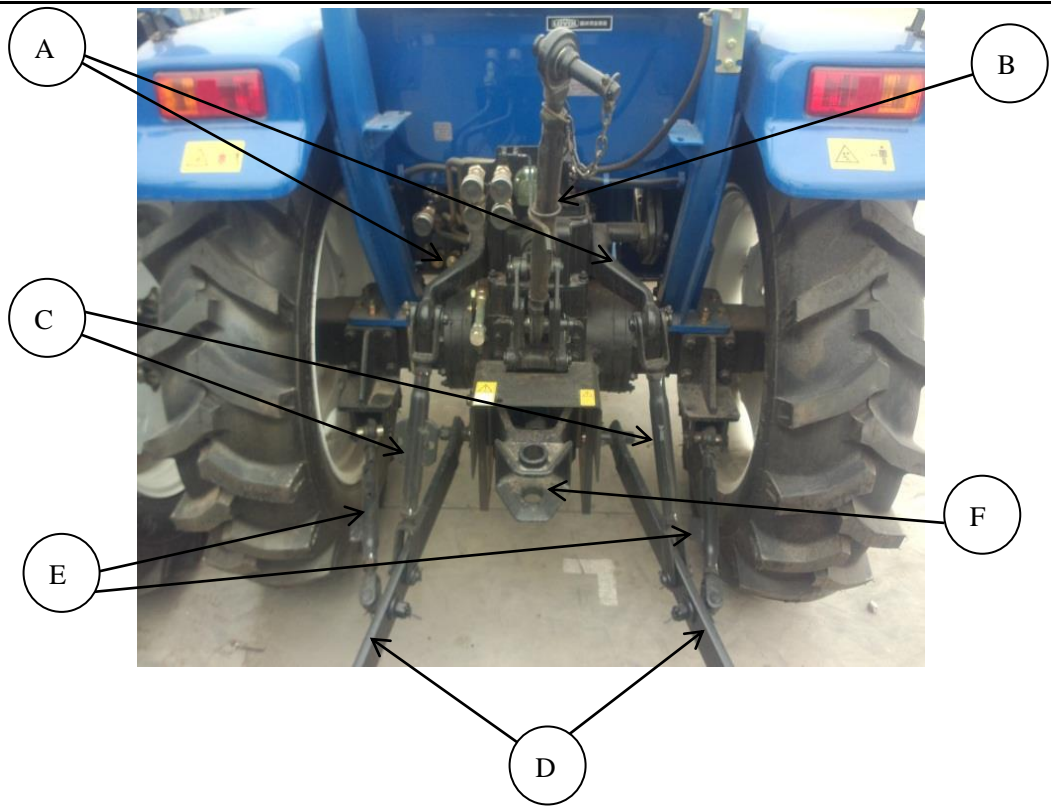

Fig. 3-45 Working device on the rear of tractor (I)

A Lift arm B Upper pull rod C Lifting rod D Lower pull rod E Limit lever F Towing point

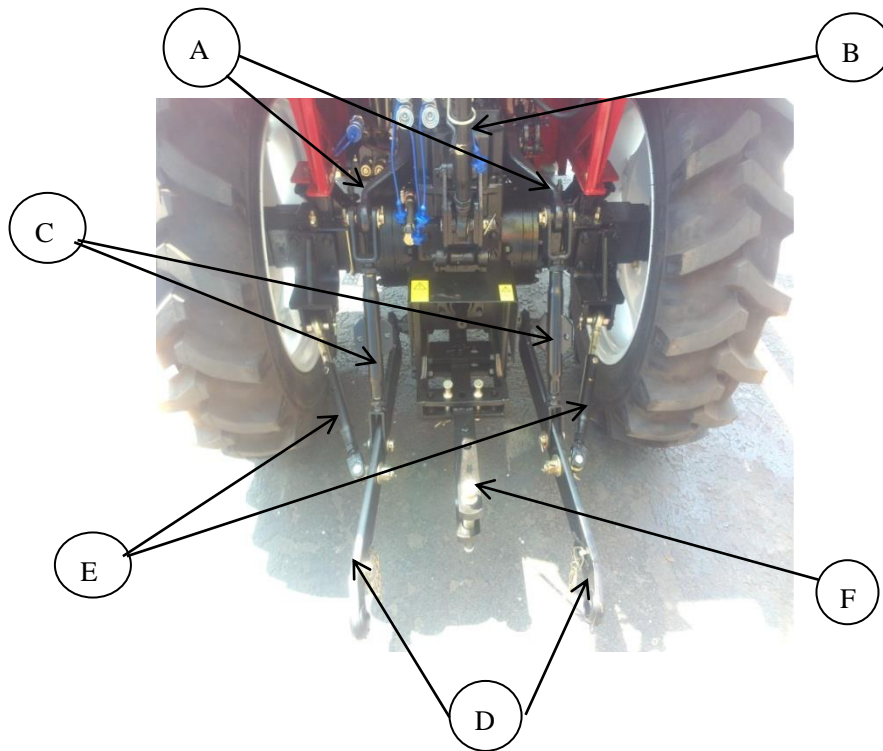
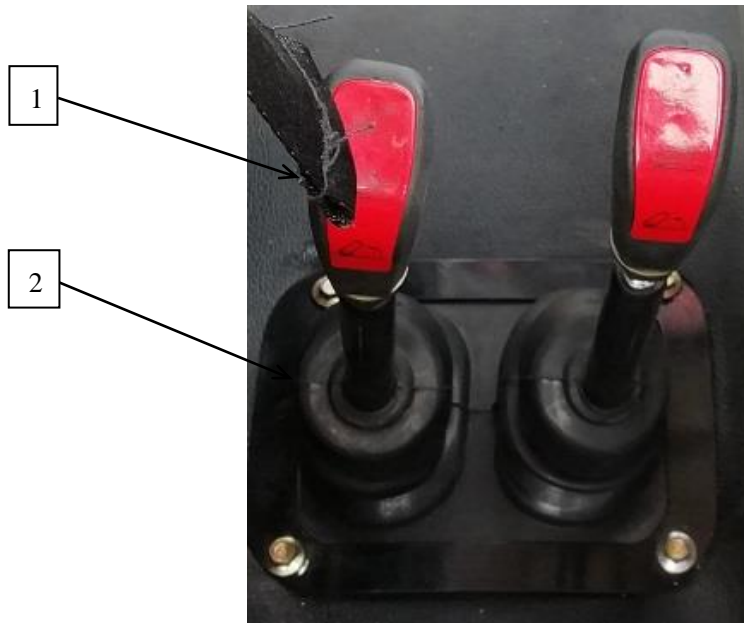

Fig. 3-46 Working device on the rear of tractor (II)

A Lift arm B Upper pull rod C Lifting rod D Lower pull rod E Limit lever F Towing point

3.15.1 Control of hydraulic lifting and suspension systems

The lifting of hydraulic suspension system is controlled by the force and position adjustment levers.



Fig,3-47 Lifting of hydraulic suspension system

1. Force adjustment lever 2. Position adjustment lever

3.15.1.1 Connecting, lifting and transfer of agricultural implements

- Prior to connecting with any agricultural implement, it's required to ensure that the pendulum type traction rod is interference-free (this traction rod can be moved forwards or removed as required) and inspect whether there is any other interference.
- Turn back the tractor towards the agricultural implement to make the towing points aligned. Then place the main shift lever onto the neutral position, depress the brake pedal, and pull up the hand brake.
- Place the hand throttle onto the lowest position, make the engine operate at idle speed for 1~2min, and shut down the engine, then connect the agricultural implement.
- Install the hinged joints(B) of lower pull rods that are hung on two sides onto the suspension pin(A) of agricultural implement, and install lock pin on two sides.
- The upper pull rod can be taken out from the fixing clip(F) of upper pull rod. The upper pull rod is connected to the column(C) of upper pull rod. Install pin and lock pin.
- Control the force and position adjustment levers respectively to realize lifting or lowering of agricultural implement.
- When the tractor with agricultural implement is subject to long-distance transfer in the transport position, the force and position adjustment levers shall be placed onto lifting position, namely the upper limit position.

- A—Suspension pin of agricultural implement
- B—Lower pull rod
- C—Column of agricultural implement
- D—Upper pull rod
- E—Lift rod
- F—Fixing clip of upper pull rod

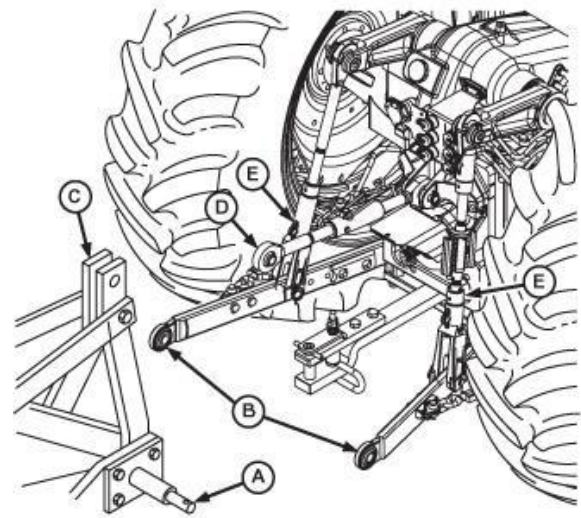
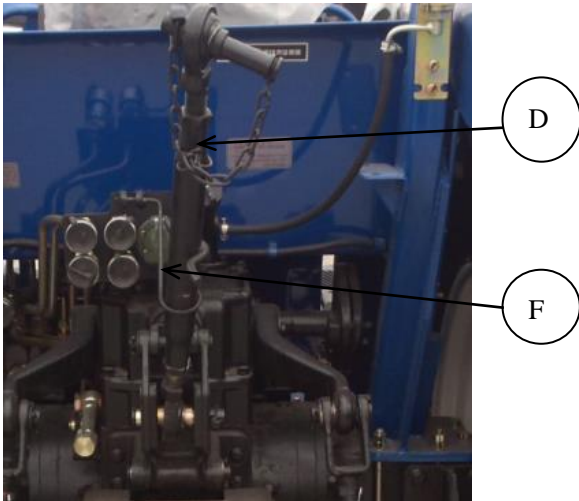

Fig. 3-48 Connecting and lifting device of agricultural implement

3.15.1.2 Adjustment of tilling depth of farm implements

Adjustment of tilling depth of farm implements includes force adjustment and position adjustment:

- Force adjustment

I.e. resistance adjustment. It automatically controls the tilling depth by using the change in the resistance of farm implements. In the ploughing work, the force adjustment is usually used. When using the force adjustment to work, first place the position control lever at the highest lifting position, move the force adjustment handle forward, and after the farm implement lowers to a certain tilling depth, it stops to lower due to the action of adjusting mechanism. The required tilling depth can be selected in the marching process of tractor, the more the forward handle movement, the more the lowering of farm implement, and the deeper the tilling depth; otherwise, the shallower the tilling depth. After selecting the required tilling depth, position the force control lever by using the force adjustment positioning device, so that it can be pushed to the same position to make the whole farming process keep the same depth. In case of undulant ground or larger change in soil resistance, the tilling depth of farm implement can be adjusted automatically.

When the arable soil resistance is increased, slightly lift the farm implement to reduce the tilling depth; when the arable soil resistance is reduced, the tilling depth will be increased automatically.

- Position adjustment

Position adjustment means the adjustment of farm implement relative to the tractor position. It is usually used for rotary tillage, harvesting, sowing, bulldozing and other operations. The position adjustment can also be

used when the farm implement is ploughing in the field with flat ground.

When using the position adjustment to work, first place the force adjustment handle at the lifting position of the highest end, move the position control lever forward, and lower the farm implement. For every position of the position adjustment handle, there is a corresponding position on the farm implement relative to the tractor, and the more the forward movement of position adjustment handle, the more the lowering of farm implement. The operating depth can be selected in the marching process of tractor, and after the farm implement reaches the required operating depth, position the position control lever by using the position adjustment positioning device, so that the position control lever can be pushed to the same position every time to ensure the farm implement is lowered to the same position.

3.15.1.3 Selection of front hinged point of upper pull rod

There are three hinged points on the front end of upper pull rod and rear end of lifter, namely upper, middle and lower hinged points.

When using the position adjustment to control the tilling depth, the front end of upper pull rod shall be connected to the lower hinged point; when using the force adjustment to control the tilling depth, use the upper hinged point in case of small soil resistance or shallow ploughing; use the middle hinged point in case of large soil resistance or deep ploughing.

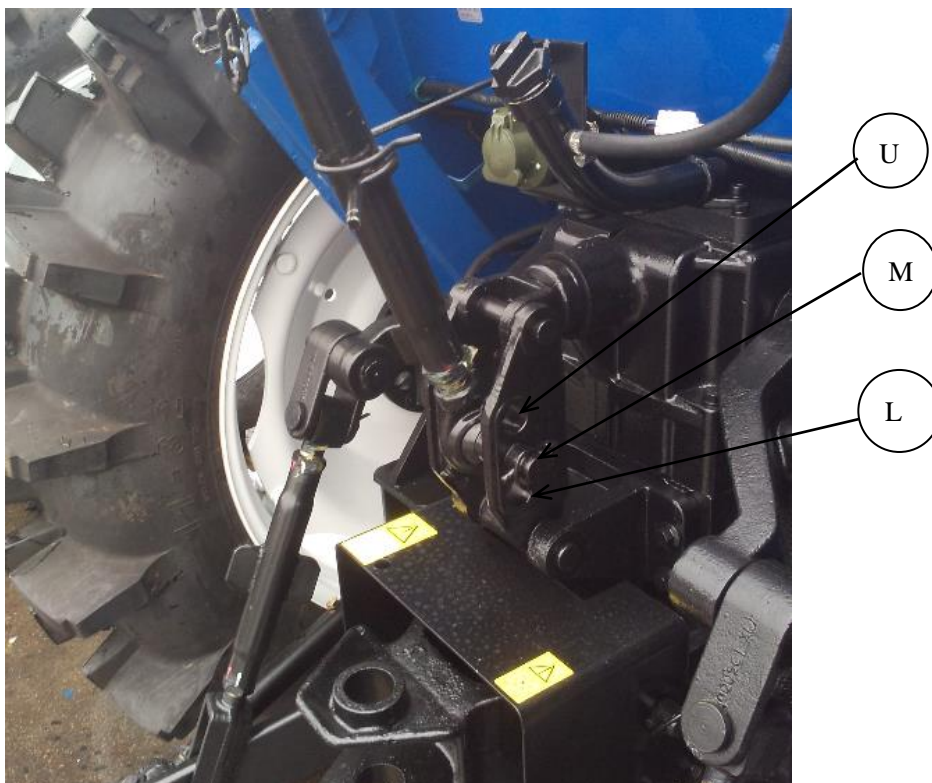

Fig. 3-49 Front hinged joint of upper pull rod

3.15.1.4 Adjustment of farm implement

The upper pull rod can be extended or shortened by adjustment to adjust front and rear horizontal positions of farm implement. The lifting rod can be extended or shortened by adjustment to adjust left and right horizontal positions of farm implement. The following instructions are given by taking the plough adjustment as an example:

- Adjustment of left and right level of plough frame: generally, adjust the length of right lifting rod to keep the plough frame level and guarantee consistent tilling depth. Loosen the nuts on both ends of spiral tube of lifting rod, clockwise rotate the adjusting plate of right lifting rod to extend right lifting rod and deepen the tilling depth of furrow plough of plough, and counterclockwise rotate the adjusting plate to shorten the lifting rod. Left lifting rod is usually not adjusted, and only when the adjustment quantity of right lifting rod is not enough, the length of left lifting rod is adjusted to meet the requirements. After adjustment, tighten the nuts on both ends of spiral tube of lifting rod to prevent their positions from being changed in use.
- Adjustment of front and rear level: adjust the upper pull rod of suspension mechanism, and when front furrow depth or rear plough heel leaves the bottom of ditch, extend the upper pull rod, and for rear furrow depth, shorten the upper pull rod to keep the plough frame level.
- Adjustment of tilling width: the adjustment of tilling width is achieved mainly by adjusting the tilling width adjuster of plough. Front and rear relative positions of left and right lower suspension points can be changed by adjusting the tilling width adjuster. If the right lower suspension point is moved forward, the tilling width will be increased; otherwise, the tilling width will be reduced. The normal position of plough frame can be guaranteed by adjusting the tilling width adjuster without backset and balk.

A—Adjusting plate of lifting rod
B—Trapezoid nut
C—Spiral tube of lifting rod



Fig. 3-50 Upper pull rod

3.15.1.5 Adjustment of lowering speed of farm implement and lifter shell of lowering speed governing valve

Properly select the lowering speed of farm implement to prevent producing serious impact when the farm implement contacts the ground that will damage the farm implement. Adjustment of the lowering speed can control the lowering speed of farm implement. When leaving the factory, the lowering speed government valve has been adjusted preliminarily. The driver can readjust the valve according to the weight of used farm implement and hardness and softness degree of ground.

The lowering speed control lever 2 is below the seat and in the floor, and after taking down the floor upper baffle 3, the lowering speed adjusting knob can be seen. After clockwise rotating the lifter lowering speed control lever 2, the lowering speed of farm speed will be reduced; otherwise, the lowering speed of farm implement will be increased.

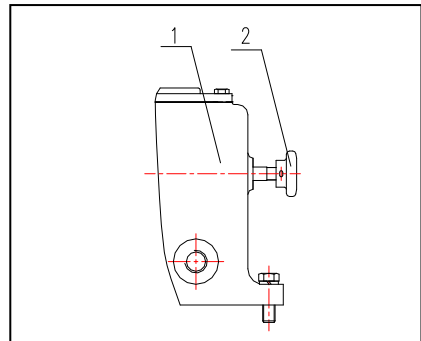
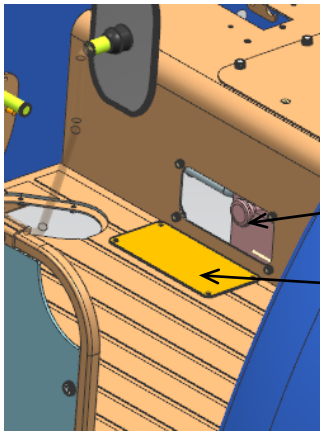

Fig. 3-51 Adjustment of lowering speed of farm implement
1. Lifter shell 2. Lowering speed



Speed control lever

Baffle

3.15.1.6 Adjustment of limit lever

The lower pull rod is allowed to swing horizontally when it is farming. To prevent the lower pull rod from bumping against the tire, limit it by the limit lever. During adjustment, make it have proper length to ensure that not only the aim of preventing the lower pull rod and farming implement from touching the rear wheel but also the lowering limit position of farming implement won't be affected. The limit lever should not be adjusted too tight to avoid damaging the components and parts.

The length of limit lever can be adjusted by

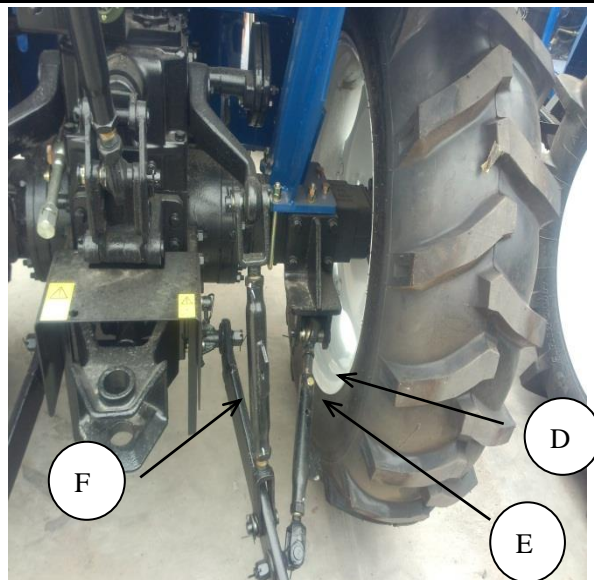

two adjusting holes on the telescopic guide rod of limit lever (D).

When the farming implement is lifted to the transport position, adjust the limit lever to the shortest position to inhibit its horizontal swing.

When swing of lower pull rod is needed, insert the limit lever lock pin (E) into long hole on the limit lever casing (F), and achieve the swing of lower pull rod by the change in the length of limit lever.

When swing of lower pull rod is not needed, insert the limit lever lock pin (E) into round hole on the limit lever casing (F), thus the length of limit lever won't change in use so as to prevent the swing of lower pull rod.

D—Telescopic guide rod of limit lever

E—Limit lever lock pin

F—Limit lever casing

Fig. 3-52 Limit lever

How to use simple hydraulically output (Figure 3-40)

When farm machine or trailer requires pressure output, the sequence shall be followed:

- Firstly make the tractor flame out, that is, to stop supplying oil to the hydraulic system from gear pump

- Push control handle for the position adjustment to the lowering position. Force the outer lifting arm to the lowest position to discharge oil from the oil tank.

- To turn the rotary shutoff valve to the limit in clockwise.

- Hydraulic oil pipe of farm machine or trailer is connected with oil pressure output pipe fitting reliably

- Push control handle for the draft adjustment to the lifting position and lock

- To start the tractor, to make the hydraulic pump normal work recovery, and control the farm machine lift or trailer automatic dumping by operation handle

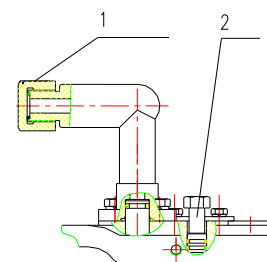

Figure 3-53 application on simple hydraulic output
1 single hydraulic output
2. shut-off value



Note:

1. When the tractor will move together with the suspension farm machine for long distance, the height should be adjusted to the minimum by upper track rod, and the machinery should be fixed by adjusting limit rod to avoid left/right swing, at the same time, the nut for upper track rod and limit rod should also be fastened, so that to prevent the farm machine damaged owing to extra-large swing

- When the tractor is steering in the end of the land, the farm machine must be lifted up before turning, and lowered when running in a straight line, so that to avoid the machine burnt.



Note:

- After adjusting the length of suspension rod piece, timely lock the lock nut to prevent premature failure of rod piece or cause other injuries;

In the driving situation without equipping machine and tool and trailer, reliably lock left and right lower pull rods with the chain ring, and insert the limit lever lock pin into round hole of limit lever to prevent bumping against other parts.

Motion Diagram of Suspension Mechanism (unit: m)

kinds of suspension systems for series TB-1 (Fig. 3-41)

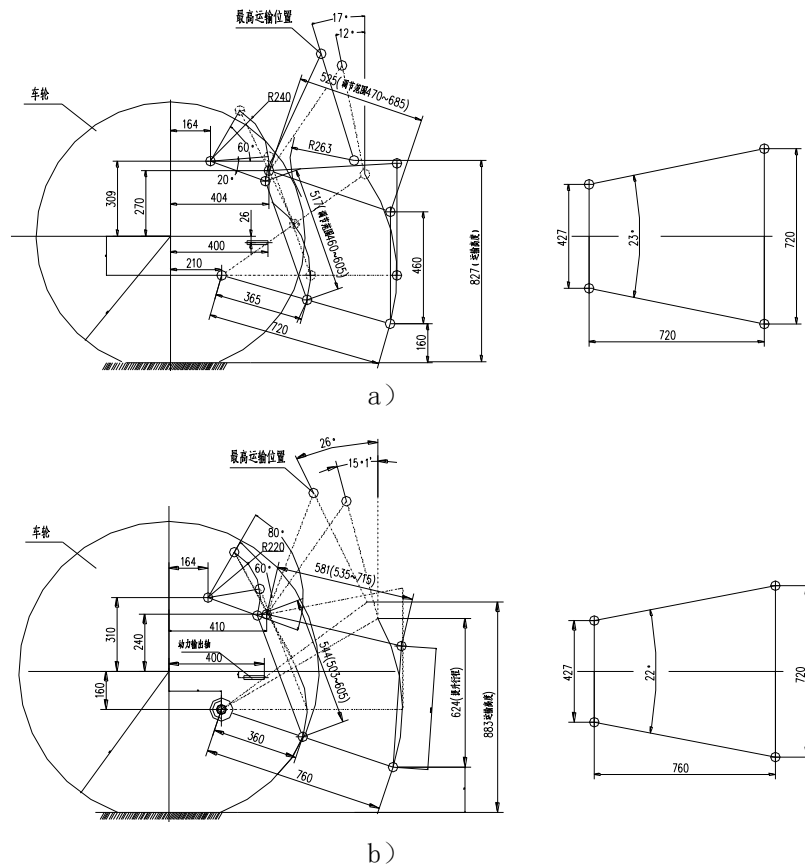

Figure 3-54

Machine below 40 horsepower machine above 45 horsepower

How to use multi-way valve hydraulic output device

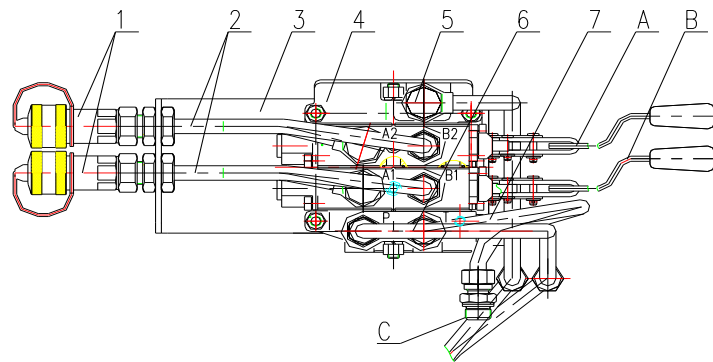

Figure 3-55 hydraulic output device

- | | | |
|------------------------|--|-------------------------------------|
| 1.Quick change coupler | 2 pressure oil pipe | 3 way valve bracket |
| 4 way valve assembly | 5 multi-way valve oil outlet pipe assembly | |
| | 6 way valve oil inlet pipe assembly | 7 way valve oil inlet pipe assembly |

The tractor can be mounted slide valve type multi-way valve as option. (Figure3-42, respectively operated by A and B operation handle to control the hydraulic cylinder attached to the farm machine . Place C: multi-way valve oil return port, the port and that of lifter housing are connected together. Each control valve is connected with 2 female connectors of quick change coupler, which are connected with AB1 and AB2 four hydraulic output oil outlets by hydraulic oil pipe. When rapid change coupler is not in use, oil inlet shall be sealed by seal cover. When using, connect the spare male joint and adapter female joint, and connect with inlet and outlet of farm machine oil cylinder. Control handle “A” controls 1st circuit hydraulic output AB2 while control handle “B” controls 2nd hydraulic output AB1.

Two hydraulic output valves can screw in or screw out single/double–action exchange screw “E” on the multi-way valve to achieve single-action hydraulic output or double-action hydraulic output. See diagram 3-43 Unscrew and exit bolt “E” counter clockwise, perform single-function, pressure output exists in port AA2. On the contrary, the screw “E” is fully screwed in to achieve double actions. Four oil inlets can be used as pressure inlets.

When using the hydraulic adapter, it firstly need to accomplish the lower part, then the male joint of farm machine can be insert to the female joint of the adapter.

- Switch off the engine
- Lower the suspension farm machine
- Move hydraulic output valve operation handle forward and backward, in order to eliminate the pressure in the hydraulic adapter seat.
- Take out sealing cover of adapter to ensure there no visible impurity.
- Connect farm machine

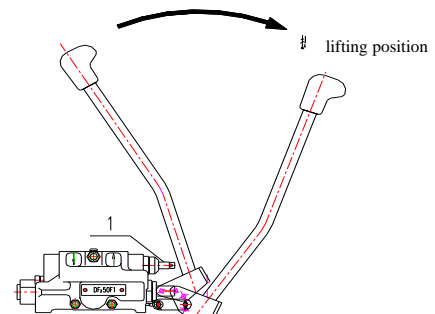

Figure 3-56 Adjustment on single-double action

1 Dual-function switchover bolt

Important notes

1. When fast change coupler is not used, seat hole shall be protected with the spare dust cover.
2. The lifter and hydraulic output valve can not be operated at the same time.
3. After hydraulically output device is operated over, its operating handle should be set to neutral position, otherwise, which may cause hydraulic system overheat
4. Draft and position control lever can control lifting farm machine. During the course of using, only one handle is operated, the other is set in the lifting position and fixed by positioning device.

3.15.2 Operation of draw and clevis coupling device

3.15.2.1 Drawbar

Drawbar can only be used in drawing implement. The back-end of drawbar connects with the implement through drawing pin. Drawbar can sway transverse, so it is easy to hang the implement. Drawbar can sway left and right when the tractor is working. But when the tractor is reversing with drawing implement, two location pins should insert into the holes of drawing plate to make drawbar not sway.

The height of drawbar point can change by turning drawbar to match the implement.

3.15.2.2 Clevis device operation

Adjustable clevis device has upper and lower working positions;

- When only uses clevis device, people can choose upper position or lower position according to the implement.
- When the tractor matches implement which is using power output shaft, it is better to choose lower working position.
- The clevis device should be in upper working position when it leaves the factory (refer to figure 3-19). Drawing pin and support sleeve should assemble together with spring lock pin, and then put in spare parts box.
- Choose suitable connecting position to connect trailer hook and tractor U-shape hook, and then use clevis pin to connect.

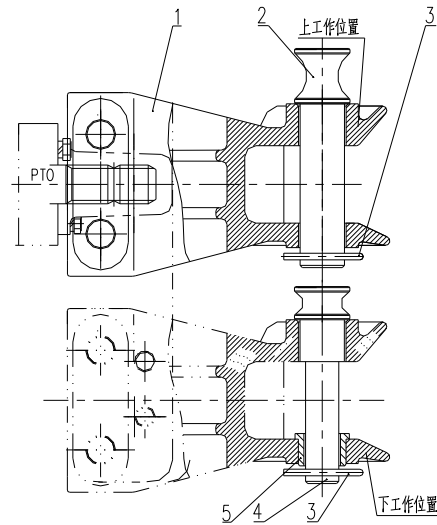

Figure 3-57 Operation of clevis device

- | | |
|--------------------|----------------|
| 1. clevis | 2. clevis pin |
| 3. spring lock pin | 4. drawbar pin |
| 5. support sleeve | |

Clevis is useful of all kinds of trailers. But it can not install with drawbar at the same time.

3.15.2.3 Use of traction device

When using the trailed implement, it is needed to use the tractor traction device. The tractor traction device is swing-rod type traction device. The swing rod has three positions for the user to choose. At each use position, it is needed to fix the swing rod with the locating pin and reliably lock the locating pin with the elastic lock pin. The factory state is shown in the figure, and according to different needs of users, the distance between the centerline of traction rod swing pin and PTO end can be adjusted, and the adjustable range is ± 50 mm (millimeter). The adjustment method is as follows: unplug the connecting pin, push forward or pull backward the swing rod, and lock it with the connecting pin.

Fig. 3-58 Use of traction device

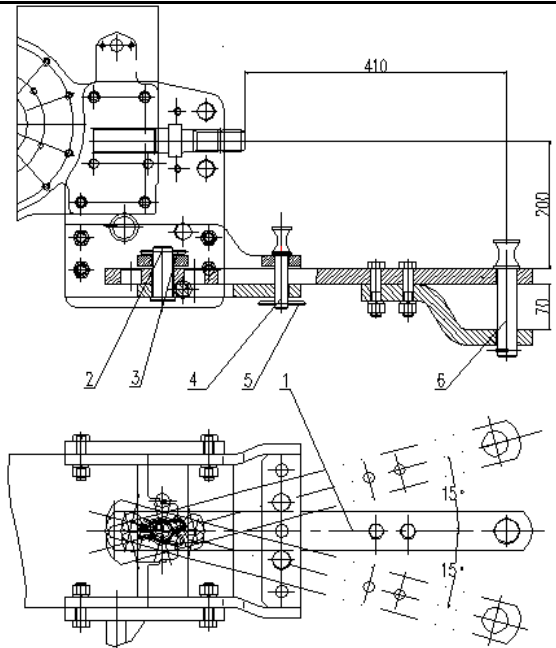

1. Swing rod 2. Connecting pin 3. Elastic lock pin of connecting pin 4. Locating pin;
5. Elastic lock pin of locating pin 6. Traction pin



Fig. 3-59 Factor state of complete vehicle with the traction rod in the middle Fig. 3-60 Rightward swing of traction rod (swinging for 15°)



Fig. 3-61 Leftward swing of traction rod (swinging for 15°)



Warning

1. Never overload while drawing and with trailer. Otherwise, it will reduce the machine lifetime. And it will cause the tractor destroy and the person die when it is seriously.
2. While braking, the braking of the trailer should be a little earlier than that of the tractor to avoid rollover.

3.15.3 Operation of power take-off

SINOVOL TB series tractor is provided with two-speed power take-off shaft, there are three kinds of combinations, the rotational speed is shown in table 3-2 [unit: r/min (revolutions per minute)] , and the operation steps of power take-off shaft are as follows:

1. Turn the control handle of power take-off shaft to the neutral position, remove the safety hood and power take-off shaft cover, and then connect the operation machinery with the power take-off shaft.
2. Depress the clutch pedal to the lowest position to disengage the power take-off clutch, and then turn the control handle to the gear position of required rotational speed. (In case of model with deputy clutch, it is needed to pull up the control handle of deputy clutch, and then turn the control handle to the gear position of required rotational speed.)

Slowly release the clutch pedal or slowly lower the control handle of deputy clutch, make the operation machinery start to run, check the running condition by means of small throttle opening, and then increase the throttle opening to put into normal operation.

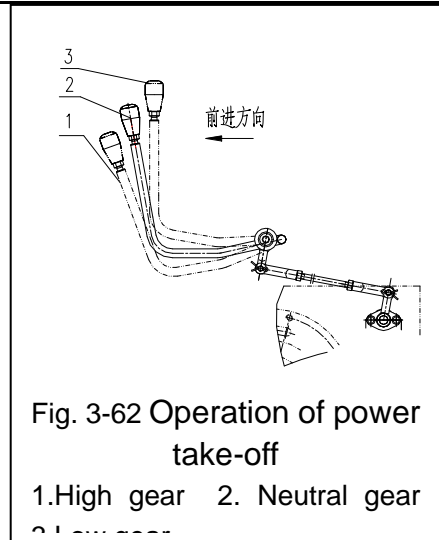

Table 3-2 Tachometer

type Shift	TB404	TB504	TB604	TB704	TB804	TB904
Low shift/high shift	540/760					



Warning: when power output is engaged, it is forbidden that anyone is close to the farm machine tool so as to prevent an accident.

3.15.4 Operation and adjustment of trailer air brake device

3.15.4.1 Composition

It adopts ventilation control system and consists of air compressor, air reservoir, air feed brake valve, safety valve and connecting pipeline.

3.15.4.2 Purpose of trailer air brake device

It is mainly used to brake the tractor trailer unit when the tractor is performing transportation operation with trailer unit to guarantee safe driving of tractor trailer unit.

3.15.4.3 Adjustment and maintenance of air brake device:

- When the tractor is performing transportation operation with trailer equipped, pay attention to observe the air pressure indicator lamp and ensure the air pressure in the air reservoir is not lower than 0.44MPa; otherwise, it is required to increase the air pressure above the specified value before driving.
- At ordinary times, the balance air pressure in the air reservoir shall not be lower than 0.70MPa . When the engine stops to work, if the air pressure in the air reservoir quickly drops, indicating that there is air leakage phenomenon, and it is required to timely check and eliminate it.
- The opening pressure of air reservoir safety valve is (0.75~0.8) MPa, and if the air pressure alarm gives an alarm in use, make adjustment timely.
- During use, if the pressure of tractor air reservoir is normal while the pressure of trailer air reservoir is lower (represented by that effective braking of trailer cannot be guaranteed), only adjust the adjusting screw on the left of brake valve.
- During use, if the air pressure of air reservoir is always in the range of (0.75~0.8)MPa or more, which indicates that the safety valve does not play a role of unloading, timely clean or replace the safety valve.
- Before the tractor performs transportation operation with trailer, it is required to check the working state of braking system of whole unit, and ensure the braking of trailer and tractor are synchronous or the braking of trailer is slightly beforehand without lagging. If necessary, adjust the adjusting screw of brake valve to meet the above requirements.



Warning:

1. If the braking of trailer lags behind the braking of main vehicle, turnover danger may be caused.
2. If two adjusting screws on the brake valve pull rod have been adjusted on special test bench when leaving the factory and coated with red mark, do not turn them randomly to avoid causing braking failure.
3. To ensure the air brake system works normally, open the drain valve to drain off water accumulated in the air reservoir every time after the tractor works for 50h (hours).

Use and adjustment of electrical system

Electrical system of the tractor is of double wire system, with negative earth. The system voltage is 12V. For the line of the whole tractor, see Figure 3-49.

Electrical equipment

The electrical equipment is mainly used to start the tractor, supervise work condition of diesel engine and illuminate and warning for the tractor.

The supervision instrument and operation switch are on the instrument console, which are in front of the driver. And the relative position between each electrical component is as shown in figure 3-2.

Electrical equipment can be divided into the following sections according to their functions:

1. Power supply part: consist of silicon rectifier integral alternator and battery.
2. Starting part: consist of electromotor and preheating plug
3. Instrument: including tachometer , water thermometer, oil gauge, counter and indicator lamp.
4. Illumination and signal device include combined head lamp, rear lamp, front signal lamp and rear combined signal lamp and flash apparatus and speaker , etc.
5. Auxiliary electrical equipment: central electrical box, rear trailer socket, ignition lock and combination switch and brake lamp switch.

How to use and maintain electrical equipment

In order to ensure the electrical system to work normal, it should be properly used and regularly maintained. To regularly check if each electrical part works normal, if the connector is loose, or if the insulation of the wire is damaged. Troubleshoot immediately when fault occurs. During working, the following key parts for the tractor should be regularly maintained:

- Secondary accumulator: the accumulator is a kind of maintenance-free lead acid accumulator, with the capacity of 100A·h .

It should be charged when the following situation occurs:

- The engine is unable to be started or the light is dim.
- Under voltage: measure the end voltage when discharging. 12V accumulator voltage is lower than 10.5V
Adjusting methods: pull out the connecting pin, push forwards or backwards the rocking arm and then lock it by connecting pin.
- It must be charged monthly if the accumulator is stored with electrolyte



Note:

1. During the process of charging, the room shall be ventilated, far away from open flame. Electrolytic solution shall not splash on the human body or clothes to avoid being damaged.
2. During the process of charging, electrolyte temperature is not higher than 45°C. At this temperature, in order to avoid an incident, charging current shall be decreased by half or stopped to lower the temperature,

but charging time shall be delayed correspondingly.

3. When charging is over, first power off to disconnect the poles to avoid fire or explosion caused by sparks

- electromotor

- When starting each time, the time for powering on ignition switch cannot exceed 5s. Continuous starting interval shall not be less than 15s. In winter before starting, first preheat the diesel engine and then switch on the actuating motor. If the diesel engine starting fails for continuous three times, it should be stopped to troubleshoot. Actuating motor shall not be used or used many times continuously so as to avoid damage the actuating motor and accumulator.
- During starting, when releasing the starting switch, the magnetic starting switch can not shut off automatically, and the starter keeps on running, it should immediately cutoff the connection between the accumulator and starter, and troubleshoot. After troubleshooting, the starter can be start again.

- Generator

It is frequent to clean the dust and oil stains on the generator surface especially dust and oil stains on the terminal. Keep good connection. V belt tightening for generator shall be appropriate. If it is too loose, it is easy to slip, resulting in generation deficiency. If it is too tightened, it will accelerate bearing wear. V belt tightening to be applicable usually when the belt will be 10~1 mm down if pressed from the middle.

- instrument

Tachometer and water thermometer are mainly used to monitor working conditions of diesel engine Oil gauge is used to supervise the level of residual diesel oil Timer is used to record the working time of the tractor Charging indicator is used to monitor the operating conditions of generator. Oil pressure indicator is used to monitor if the diesel engine lubrication system operates normally. If abnormal, stop to check immediately and troubleshoot.

- Illumination and signal device

Illumination and signal device is mainly used for tractor working or transportation at night, which can illuminate the surrounding or the attached agriculture machinery. Therefore, when fault occurs, the tractor should stop immediately to check, if something damage, change attachment pf the same type.

● **Auxiliary electrical equipment**

- Fuse box: 15 shifts, totally, 7 shifts for currently used shifts, and the others for spare. Overhaul immediately. Fuse is mainly used to protect electrical equipment, its specification should coincide with drawing sample requirements. If burnt too much, it's necessary to troubleshoot in time. It is prohibited to modify any fuse specification, otherwise, the power-used equipment will be damage.
- Ignition lock is used to switch on the circuit, preheat and start diesel engine. Put the key into ignition lock hole, turn clockwise to ON position and switch on the whole circuit. Turn clockwise to H gear and switch on preheating device. Turn clockwise to ST shift and switch on the actuating motor. After the diesel engine is started, the key returns to the ON position after releasing. During the course of operation, the key is always in ON position. When the tractor is not in use for a long time, the key shall be taken out to disconnect electrical line of the whole tractor.
- Rear trailer socket: in order to add the trailer signal lamp when the tractor is equipped with the trailer, the tractor is installed with rear trailer socket and equipped with the plug pin in the spare part box. For the socket wiring position, please see Diagram 3-44

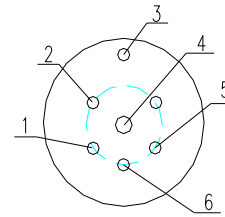

Figure 3-63 wire to connect on right steering lamp

1. Connect power cable of working lamps
2. Earth wire
3. Connect power cable of position lamps
4. Connect power cable of brake lamp
5. Connect power cable of the left steering lamp

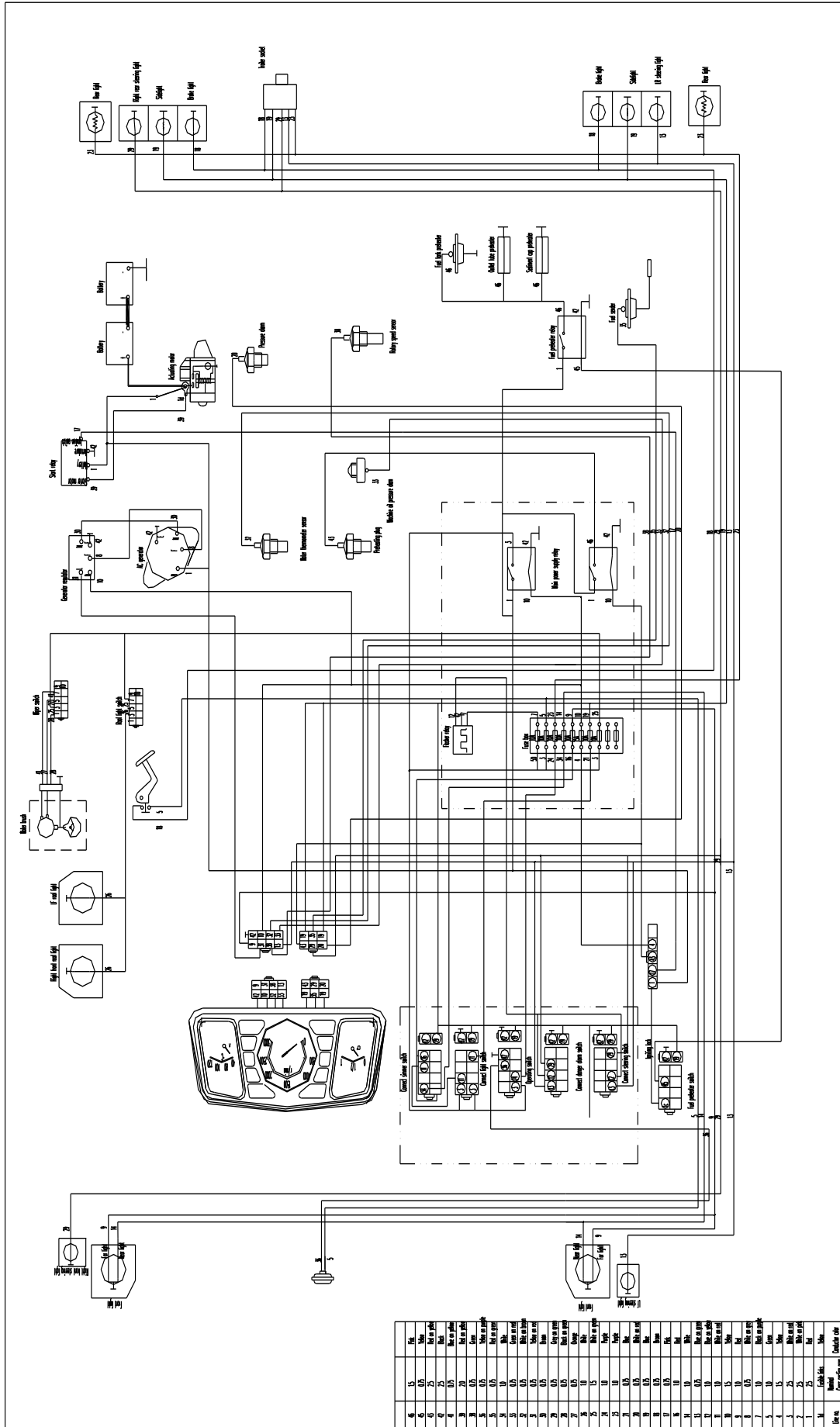

Fig 3-64 Vehicle line

3.16 Tractor running in

Preparations before running-in

- Check and tighten fasteners outside.
- Fill lube grease in every lube point
- Check diesel engine, gearbox, rear axle, auxiliary box, final drive and front drive axle (4-wheel drive tractor, steering gear, lifter and oil level in fuel oil tank). Refill if necessary.
- Fill fuel oil and cooling water
- Check tyre pressure
- Check the accumulator electrolyte specific gravity and electrolyte level
- Auxiliary box control handle is placed at operating shift (4-wheel drive tractor)

Engine running in at idle running

Diesel engine runs at low, medium and high speed in turns. Running times is 7min, 5min and 3min, respectively. During the diesel engine running in with no load, it should be carefully checked whether there is abnormal noise or abnormal situation, or oil leakage , or if engine oil pressure is normal, When any abnormal condition occurs, stop immediately and troubleshoot. Then run in again.

Power output shaft running in

When the diesel engine are running at middle oil throttle, respectively set the power output handle on high and low speed position to running for each 5 minutes, then set the power output handle on neutral position

Hydraulic system running-in

After the suspension mechanism is mounted with the matching farm machine , to operate the lifter handle under the maximum oil throttle of diesel engine, to lift the suspension up/downward for 10 minutes with minimum 20 times. After running-in, put the distribution handle on Lower position.

The tractor running with no load and running-in with load

When running in, the shift is from low to high, the load is from light to heavy. During the dead load and light load running-in, throttle opening is 3/4. For the other two running-in conditions, the throttle is fully open.

When running-in, pay attention to

- Operating conditions of diesel engine, drive system and running steering system, and instrument readings
- Check if clutch, gearbox, auxiliary box, front drive axle and brake operates normally
- Differential lock can engage and disengage or not
- Operating conditions of electrical equipment
- If any abnormality or fault occurs during the running-in, first find out the reasons and troubleshoot, then continue to run in.

Running-in time for each stage

Table 3-3 Running-in specifications of SINOVOL TB series tractor 8F+4R

Traction load (kN)			0	3~4	7~8	10.5~11.5
Equivalent operation items			Empty driving	Transportation of cargo with mass of 2t by the traction trailer	The mounted plough is working on the sandy soil [specific resistance: (30 ~35) kPa], ploughing with tilling depth of (18~20) cm	The mounted plough is working on the clay soil [specific resistance: (45 ~50) kPa], ploughing with tilling depth of 20cm
Throttle opening			3/4	3/4	Fully open	Fully open
Direction	Auxiliary gearbox	Main gearbox				
Forward gear	Low gear	1	0.5			
		2	0.5			
		3	0.5	2	10	9
		4	0.5	2	10	10
	High gear	1	0.5	3	10	11
		2	0.5	3	10	9
		3	0.5	2		
		4	0.5	2		
Reverse gear	Reverse gear	1	0.5			
		2	0.5			
		3	0.5			
		4	0.5			
Total hours (h)			7	14	40	39

Table 3-4 Running-in specifications of SINOVOL TB series tractor 8F+8R

Traction load (kN)			0	3~4	7~8	10.5~11.5
Equivalent operation items			Empty driving	Transportation of cargo with mass of 2t by the traction trailer	The mounted plough is working on the sandy soil [specific resistance: (30 ~35) kPa], ploughing with tilling depth of (18~20)cm	The mounted plough is working on the clay soil [specific resistance: (45 ~50) kPa], ploughing with tilling depth of 20cm
Throttle opening			3/4	3/4	Fully open	Fully open
Direction	Auxiliary gearbox	Main gearbox				
Forward gear	Low gear	1	0.5			
		2	0.5			
		3	0.5	2	10	9
		4	0.5	2	10	10
	High gear	1	0.5	3	10	10
		2	0.5	3	10	9
		3	0.5	2		
		4	0.5	2		
Reverse gear	Reverse gear	1	0.5			
		2	0.5			
		3	0.5			
		4	0.5			

Traction load (kN)			0	3~4	7~8	10.5~11.5
Equivalent operation items			Empty driving	Transportation of cargo with mass of 2t by the traction trailer	The mounted plough is working on the sandy soil [specific resistance: (30 ~35) kPa], ploughing with tilling depth of (18~20)cm	The mounted plough is working on the clay soil [specific resistance: (45 ~50) kPa], ploughing with tilling depth of 20cm
Throttle opening			3/4	3/4	Fully open	Fully open
Direction	Auxiliary gearbox	Main gearbox				
	Reverse gear	1	0.5			
		2	0.5			
		3	0.5			
		4	0.5			
Total hours (h)			8	14	40	38

Table 3-5 Running-in specifications of SINOVOL TB series tractor 12F+12R

Traction load (kN)			0	3~4	7~8	10.5~11.5
Equivalent operation items			Empty driving	Transportation of cargo with mass of 2t by the traction trailer	The mounted plough is working on the sandy soil [specific resistance: (30 ~35) kPa], ploughing with tilling depth of (18~20)cm	The mounted plough is working on the clay soil [specific resistance: (45 ~50) kPa], ploughing with tilling depth of 20cm
Throttle opening			3/4	3/4	Fully open	Fully open
Direction	Auxiliary gearbox	Main gearbox				
Forward gear	Low gear	1	0.5			
		2	0.5			
		3	0.5			
		4	0.5	2		
	Intermediate gear	1		2	10	9
		2		3	10	9
		3		3	10	10
		4		2	10	8
	High gear	1	0.5	2		
		2	0.5	2		
		3	0.5			
		4	0.5			

Traction load (kN)		0	3~4	7~8	10.5~11.5	
Equivalent operation items		Empty driving	Transportation of cargo with mass of 2t by the traction trailer	The mounted plough is working on the sandy soil [specific resistance: (30 ~35) kPa], ploughing with tilling depth of (18~20)cm	The mounted plough is working on the clay soil [specific resistance: (45 ~50) kPa], ploughing with tilling depth of 20cm	
Throttle opening		3/4	3/4	Fully open	Fully open	
Direct ion	Auxiliary gearbox	Main gearbox				
Reverse gear	Low gear	1				
		2				
		3				
		4				
	Intermediate gear	1	0.5			
		2	0.5			
		3	0.5			
		4	0.5			
	High gear	1	0.5			
		2	0.5			
		3	0.5			
		4	0.5			
Total hours (h)		8	16	40	36	

Table 3-6 Running-in specifications of SINOVOL TB series tractor 16F+8R

Traction load (kN)		0	3~4	7~8	10.5~11.5
Equivalent operation items		Empty driving	Transportation of cargo with mass of 2t by the traction trailer	The mounted plough is working on the sandy soil [specific resistance: (30 ~35) kPa], ploughing with tilling depth of (18~20)cm	The mounted plough is working on the clay soil [specific resistance: (45 ~50) kPa], ploughing with tilling depth of 20cm
Throttle opening		3/4	3/4	Fully open	Fully open

Direction	Creeper gear	Auxiliary gearbox	Main gearbox				
Forward gear	Low gear	Low gear	1	0.5			
			2				
			3				
			4				
		High gear	1				
			2	0.5			
			3				
			4				
	High gear	Low gear	1	0.5			
			2	0.5			
			3	0.5	2	10	13
			4	0.5	2	10	12
		High gear	1	0.5	3	10	12
			2	0.5	3	10	
			3	0.5	3		
			4	0.5	3		
Reverse gear	Low gear	Reverse gear	1				
			2				
			3				
			4				
	High gear	Reverse gear	1	0.5			
			2	0.5			
			3	0.5			
			4	0.5			
Total hours (h)				7	16	40	37

Operations after running-in

Once the load running is over, the tractor shall be put into use only after the following operations are made.

- After parking, to drain the warm lube oil in diesel engine oil pan, wash the pan, engine oil filter screen and air separator, and fill fresh lube oil.
- Before cooling, discharge engine oil inside gearbox, rear axle, auxiliary box, final drive, front drive axle

and steering system, clean oil drain plug and magnet, and then fill an appropriate amount of diesel oil. Run at shift II and reverse gear shift for 2~3min, respectively. Then discharge diesel oil and replace with new lube oil;

- Wash fuel oil air separator (including oil filter and air separator in the fuel oil tank)
- Drain the cooling water and clean the cooling system of diesel engine by water;
- Before cooling, discharge heavy-duty oil in hydraulic system, replace with new oil after cleaning.
- Check toe-in and free strokes for clutch and brake pedal. Adjust if necessary.
- Check and tighten bolts and nuts for each main components
- Check oil nozzle and clearance of air valve. Adjust if necessary
- Check the operating conditions of electrical system
- Fill lube grease in every oil cup

3.17 Troubleshooting for tractor

Troubleshooting of Chassis

Trouble shooting of Clutch (Table 3-4)

Table 3-4 Trouble shooting of Clutch

Problem	Possible Cause	Remedy
Clutch is not disengaged completely	Pedal spare travel is too large and work travel is too little.	Readjust according to requirements
	Driven disk over-bowing	Replace
	Disengaging lever heads are not on the same plane	Adjust
The tractor starting is wobbling.	Oil stains on main friction lining and driven disk	Wash with gasoline.
	Friction lining broken	Replace
	Driven disk bowing	Correct
	Disengaging levers are not in the same plane	Adjust
Clutch slipping	Oil stains on the friction lining and pressure plate	Wash with gasoline, and troubleshoot oil leakage fault
	Friction lining wear is uneven or severe, with rivets exposed.	Replace friction lining
	Butterfly spring pressure weakening	Replace
	Free stroke is small, disengagement levers are not on the same plane and contact disengagement bearing.	Readjust according to requirements
	Driven disk deformed	Replace driven disk
The clutch pedal is stepped on to the lowest position, but power output shaft is still rotating	Pedal position bolt in improper position.	Adjust
	Clutch pressure plate disengagement for power output shaft is not in the right position.	Readjust according to requirements

Trouble Shooting of Gearbox (Table 3-5)

Table 3-5 Trouble shooting of Gearbox

Problem	Possible Cause	Remedy
Gearbox with abnormal sound or strikes	Gear and tooth surface worn or gear surface peeled off, with a crack or gear tooth broken off.	Replace with new gear
	Bearing worn seriously or damaged	Replace bearings
	Lubrication is insufficient or quality disaccord with the requirement	Fill or replace lube oil
It is difficult to shift gears or put into gear	Clutch is not disengaged completely	Adjust the clutch
	Engaged bushing, spline shaft tooth end worn or with a notch	Repair or change
Disengage automatically	With spare safety lever for various specifications	Repair or change
	Pull out pegs broken or failed	Replace lock spring
	Engaged bushing spline worn	Replace sliding gear with engaged sleeve

Trouble shooting of Rear axle (Table 3-6)

Table 3-6 Trouble shooting of Rear axle

Problem	Possible Cause	Remedy
Noise for central drive is increased	Active spiral bevel gear bearing has a clearance	Adjust the clearance
	Gear engagement abnormal	Readjust engagement trace and clearance, side clearance accords with the requirement of instruction manual
	Differential gear shaft worn or stuck	Replace
	Planet gear or gasket worn	Replace
	Differential gear broken or damaged	Replace
Active spiral bevel gear bearing and differential gear bearing overheating	1. Bearing pretightened too much 2. Lubrication is invalid	1. Readjust 2. Check oil level. Refill if necessary

Troubleshooting of Brake (Table 3-7)

Table3-7 Trouble shooting of Brake

Problem	Possible Cause	Remedy
Brake invalid	Friction lining worn severely or unevenly	Replace
	Brake pedal travel is extra large	Adjust
When braking, the tractor runs eccentrically	Left/right brake pedals have different stroke lengths.	Adjust
	Brake friction lining on one side damaged	Replace
	Pressure in two rear tyres is different	Fill air according to pressure specified
The tractor starting is	Brake pedal travel is too small	Adjust

Problem	Possible Cause	Remedy
wobbling.	Pedal reset spring force is too small.	Replace
Brake does not completely release and feels hot,	Parking brake not released	Release parking brake
	Brake pedal travel is too small	Adjust

Trouble shooting of Front drive axle (Four-wheel Drive Device, Table 3-8)

Table 3-8 Troubleshooting of Front drive axle

Problem	Possible Cause	Remedy
Front wheel tyre seriously worn	Front wheel ring or disc seriously worn	correct
	Toe-in of front wheel is abnormal	Adjust
	Steering knuckle connection pin worn seriously	Replace
	Because of long-period operation, air pressure of front wheel is not enough or front drive axle and handle are not disengaged.	Fill air and disengage front drive according to requirements
Front wheel swing	The front axle is seriously worn	Replace
	Steering knuckle arm support bushing bearing worn seriously	Replace
	Clearance between front/rear bearing is extra-large	Adjust
	Front wheel ring seriously worn	Correct
	Toe-in of front wheel is abnormal	Adjust
	Steering ball joint worn seriously	Replace
Drive shaft and sleeve becoming heating	Drive shaft sleeve bent or seriously deformed	Correct
Large noise	Engagement trace of front central drive gear is abnormal	Readjust
	Clearance between central drive bearing is too large or destroyed	Readjust or change
	Differential gear shaft worn or stuck	Replace
	Planet gear or gasket worn	Replace
	Drive gear pair engages not good.	Replace

Trouble shooting of steering system and running system

Table 3-9 Trouble shooting of Steering system and running system

Problem	Possible Cause	Remedy
Free stroke of steering system is too large.	Steering gear thrust bearing worn	Replace bearings or adjust
	Steering gear screw, nut and ball worn	Replace wearing parts
	Gear sector and rack worn	Adjust
Mechanical and hydraulic steering is too heavy	Upper ball screw seat of steering thrust bearing is tightened too much.	Properly tighten upper ball screw seat
	The air pressure of front wheel tyre too low	Fill air according to requirements

Problem	Possible Cause	Remedy
	Oil delivery of gear oil pump is not enough. Gear oil pump leaks inside or oil screen inside the steering oil tank is blocked, light at slow speed and heavy at rapid speed	Check if gear oil pump is normal. Clean the filter screen.
	Air exists in steering system, when rotating steering wheel, oil cylinder sometimes moves and sometimes does move.	Discharge the system and check if any air is in the oil inlet line
	Oil level in steering oil cylinder is insufficient.	Fill oil to the specified level
	Spring elasticity in relief valve becomes weak, or steel ball is not sealed, light load is steering lightly, and steering becomes heavier if load is increased.	Wash safety valve and adjust safety valve spring pressure
	Oil viscosity too high	Apply the specified oil liquid
	Steel ball check valve in the valve body fails, steering wheel is heavy when turning it slowly or quickly, and steering is weak.	Clean, maintenance and change
	Oil leakage from steering system, including inside and outside.	Check and find out leaking points
Front wheel swing	Clearance between taper roller bearing of front bearing is extra-large	Adjust the clearance to the specified requirements
	Steering ball joint worn seriously	Replace
	Gasket worn between the swing shaft and bracket	Replace
	Toe-in of front wheel is abnormal	Adjust
	Front wheel ring seriously worn	Correct
Earlier wear for tyre	Toe-in of front wheel is abnormal	Adjust
	Pressure in the tyre is not appropriate	Fill air according to requirements
	Drive tyre thread mounted in reverse	Reassemble
Hydraulic steering invalid	Gear shifting fork locating slot worn	Replace pull out pegs
	Linkage shaft opening broken or deformed	Replace coupled axle
	Rotor and linkage shaft are mounted wrongly.	Reassemble
	Steering oil cylinder piston or piston seal ring damaged.	Replace the piston or the seal ring
Steering wheel can not return to neutral position when hydraulic steering	Spring piece broken off	Replace spring piece
	Steering shaft and steering column bushing are not on the same center, so rotating resistance is large.	Repair or change
	Steering shaft ejects to valve core in axial direction	Repair

Problem	Possible Cause	Remedy
	On neutral position, when the pressure is too large or steering wheel stops running, the steering device will not discharge.	Repair or change
	Steering shaft and valve core are not on the same point.	Reassemble and adjust
Hydraulic steering without person power	Clearance between rotor and stator is too big.	Replace rotor or stator
	Sealing for oil cylinder piston is worse, the driver can not have obvious ending feel when the piston reaching the limit during power steering. And the steering wheel rotaries while the oil cylinder does not move during power steering.	Replace the piston seal ring

Troubleshooting for hydraulic system

Table 3-10 Troubleshooting of Hydraulic System

Problem	Possible Cause	Remedy
Lifter starting failure, the lifter can not start	Oil level too low or oil type wrong	Fill sufficient qualified machine oil
	Filter screen blocked	Wash filter
	Hydraulic system suck air	Discharge the air and tighten the fitting or replace seal ring
	Oil pump serious worn, and interior oil leakage serious	Replace oil pump seal ring
	Main control valve or oil return valve blocked	Lifter control handle is lifted several times. A screwdriver is used to turn the main control valve. If it is stuck continuously, remove and clean it.
	Main control valve or oil return valve worn seriously	Replace wearing parts
	Relief valve failure	Readjust or repair
	Oil pump oil leakage serious	Replace seal ring, replace wearing parts if necessary
	Each seal ring in the distributor leaks	Replace seal ring
Farm machine cannot be lowered	Main control valve or oil return valve blocked	Lifter control handle is lifted several times. A screwdriver is used to turn the main control valve. If it is stuck continuously, remove and clean it.
	Lowering speed adjustment valve or cutoff valve is closed.	Open the valve
Farm machine is trembling during the lifting course.	Check valve worn, not tightened	Repair or change check valve
	Oil distributors and each seal ring of oil tank leak	Find out oil leak point, and change sealing ring
When using simple hydraulic	Shut-off valve has not shut off the oil line.	Screw shut-off valve into shut-off oil circuit of housing in sequence specified.

Problem	Possible Cause	Remedy
output, oil pressure is naught or too low.	Draft control handle or position control handle is put in the lowering position.	Draft and position control lever is in lifting position
	Make the lift arm on lift position	Make the lift arm on lower position
	When using the adapter, the adapter female joint or male joint core is blocked, the oil piping is blocked.	Replace quick change coupler

Troubleshooting of Electrical system

Table 3-11 Troubleshooting of Electrical system

Problem	Possible Cause	Remedy
electromotor does not run	Wiring disconnects or poor contact exists	Weld or replace with new wire
	Accumulator with no power or voltage too low	Charge to the accumulator
	The carbon brush contacts commutator, the commutator is dirty	Adjust the carbon brush spring pressure and clean the commutator
	Electromotor internal open circuit, short circuit or grounding	Check and eliminate short circuit and open circuit
Electromotor start failure, the electromotor can not start	Bearing worn seriously, armature peeling off	Replace with new bearing
	The contact between carbon brush in invalid	Adjust
	Rectifier surface burnt or contaminated by oil	Remove oil filth, polish with O# non-metal sandpaper
	Poor wire connection	Fasten the nut
	Main contact of solenoid switch is burned, resulting in poor connection	Remove oil filth, polish with O# non-metal sandpaper
	Accumulator charge invalid or voltage too low	Accumulator charge
The generator does not generate	Armature open circuit	Check and troubleshoot
The generator is under charge or the current is instable	Fan V belt slips and rotary speed of diesel engine is reduced.	Adjust V belt tightening
	Circuit connection is loose	Fasten the screw
	Armature open circuit	Check and troubleshoot
	Regulator fault	Check and troubleshoot
If power reserve for the accumulator often is not enough	The generator or regulator is faulty, without any current.	Overhaul the engine or regulator. If regulator contacts is in poor connection, “0” # non-metal sandpaper is used to grind it.
	Connection in charging circuit is loose	Check if accumulator joint and wiring studs are loose. Tighten if necessary.
	Pole plate short circuit	Overhaul

Problem	Possible Cause	Remedy
If the accumulator is extra-charged (the distilled water is consumed too much, the electrolyte is out of the gas hole)	The regulator cannot keep normal voltage for the generator	Adjust

3.18 Engine fault and troubleshooting

Fault phenomenon	Fault cause	Troubleshooting
It is difficult to start the engine or the engine cannot be started.	Improper starting process	Check the starting procedure
	No fuel	Check the fuel tank.
	There is air in the fuel system.	Exhaust air.
	The hand oil pump handle is lifted but is not lowered.	Make the hand oil pump handle return to its original position.
	Low starter speed	View “Slow starting speed of starter”.
	Too high viscosity of crankcase oil	Use oil of proper viscosity.
	Incorrect grade of diesel oil	Inquire and use proper diesel oil.
	There are water, air and foreign matter in the fuel system.	Draining, flushing, add oil and exhaust air.
	Blockage of fuel filter	Replace the filter element.
	Blockage of fuel injector or poor fuel injection	Please inform the dealer of handling the fault.
Engine knock	Insufficient fuel	Add oil.
	Incorrect advance angle of fuel supply	Please inform the dealer of handling the fault.
	Low coolant temperature	Please inform the dealer of handling the fault.
	Engine overheating	View “Engine overheating”.
Unstable engine speed or engine stall	Low coolant temperature	Please inform the dealer of handling the fault.
	Blockage of fuel filter	Replace the filter element.
	There are water, air and foreign matter in the fuel system.	Draining, flushing, add oil and exhaust air.
	Blockage of fuel injector or poor mist spraying	Please inform the dealer of handling the fault.
	Incorrect grade of diesel oil	Use specified diesel oil.

Too low engine temperature	The thermometer or sensor is faulty.	Check the thermometer and sensor.
Insufficient engine power	Engine overloading	Reduce load or shift to low gear.
	Low maximum idle speed	Please inform the dealer of handling the fault.
	Insufficient intake	Please inform the dealer of handling the fault.
	Blockage of fuel filter	Replace the filter element.
	Incorrect grade of diesel oil	Use specified fuel.
	Engine overheating	View "Engine overheating"
	Too low engine temperature	Please inform the dealer of handling the fault.
	Incorrect valve clearance	Please inform the dealer of handling the fault.
	Poor mist spraying of fuel injector	Please inform the dealer of handling the fault.
	Incorrect advance angle of fuel supply	Please inform the dealer of handling the fault.
	Turbocharger fault	Please inform the dealer of handling the fault.
	Insufficient oil supply of oil supply tube	Please inform the dealer of handling the fault.
	Blocked oil return tube	Please inform the dealer of handling the fault.
Inappropriate balance weight	Adjust the balance weight.	
Low oil pressure	Low oil level	Add oil.
	Incorrect oil grade	Drain oil, and add oil of specified grade.
High oil consumption	Too low oil viscosity	Use oil of proper viscosity
	There is part with oil leakage.	Check the oil tube, sealing gasket and oil drain bolt
	Blockage of crankcase ventilation tube	Clean the ventilation tube.
The engine belches black or gray smoke.	Incorrect fuel grade	Use fuel of correct grade.
	Blockage of air filter	Clean the air filter.
	Engine overloading	Reduce load or shift to low gear.
	There is foreign matter in the fuel injection nozzle.	Please inform the dealer of handling the fault.

	Turbocharger fault	Please inform the dealer of handling the fault.
	Incorrect advance angle of fuel supply	Please inform the dealer of handling the fault.
The engine belches white smoke.	Incorrect fuel grade	Use fuel of correct grade.
	The engine is beyond service period.	Please inform the dealer of handling the fault.
	The thermostat is faulty.	Replace the thermostat.
	Blockage of fuel injection nozzle	Please inform the dealer of handling the fault.
	Turbocharger fault	Please inform the dealer of handling the fault.
	Failure of cold start or light load advancer	Please inform the dealer of handling the fault.
	The engine is too cold.	Preheat the engine.
Engine overheating	Blockage of radiator core or dirty of grid	Clean the surface.
	Engine overloading	Shift to low gear or reduce load.
	Low oil level.	Check the oil level, and add oil to the required oil level.
	Less coolant	Add coolant to the radiator, and check whether there is leakage at the joint of radiator and hose.
	Damage of radiator cap	Replace
	Too loose fan belt	Adjust the tightness of fan belt.
	The cooling system needs cleaning.	Clean the cooling system.
	The thermostat is faulty.	Please inform the dealer of handling the fault.
	The thermometer or sensor is faulty.	Please inform the dealer of handling the fault.
	Incorrect fuel grade	Use proper diesel oil.
	Improper fuel level	Use diesel oil of proper level.
	Blockage of air filter	Clean the air filter.
	Engine overloading	Shift to low gear or reduce load.
	Incorrect valve clearance	Please inform the dealer of handling the fault.
	Blockage of fuel injection nozzle	Please inform the dealer of handling

			the fault.
		Incorrect engine timing	Please inform the dealer of handling the fault.
		Improper adjustment of farm implement	See <i>Operation Manual of Farm Implement</i> .
		Low engine temperature	Please inform the dealer of handling the fault.
		Too large balance weight	Adjust the balance weight.
		Blockage of intake system	Check
		Blockage of crankcase ventilation tube	Clean the ventilation tube.
		Turbocharger fault	Please inform the dealer of handling the fault
Diesel engine switches off automatically	the crankshaft does not rotate after stopping	Crankshaft and axle bush locking-up	Check crankshaft and axle bush, repair crankshaft, change axle bush
		Piston and cylinder liner locking-up	Change piston and cylinder liner
	Crankshaft can easily rotate after stopping	Fuel system inlet air	Eliminate air
		Fuel system blockage	Remove blockage
		Air filter clogging	Maintenance air filter
		Fuel exhaustion	Filling fuel tank
		Governor maladjustment, Rack card without oil supply position	Check and repair

4. Accessories, spare parts and consumables

In order to much better fulfill the tractor function and more safely operate the tractor, TB series tractor can provide various accessories and spare parts. The customer must apply suitable accessories and spare parts as required;

4.1 Accessories

Tractor accessories mainly includes cab, safety frame, swing traction rod, etc;

4.1.1 Cab (option)

TB-1 series tractor can be with three kinds of cabs, such as simple-fan type, luxury-fan model and luxury-warm air blower model, which will provide a comfortable working circumstance for the driver.

When ventilation is needed in the cab, especially in summer, semi-open mechanism on the door can be opened in order to guarantee the ventilation for the driver during running.

4.1.2 Safety frame (option)

TB-1 series tractor can be with OECD safety frame to prevent the driver from being hurt by accident turnover.

4.1.3 Swing traction rod (option)

Just used for traction type farm machine Traction rod rear end connected with farm machine by traction pin Traction rod can transversally swing, which will be more convenient for mounting farm amchine Traction rod can swing to right/left. However, when the tractor is towing farm machine backward, positioning pin 1 must be inserted into the hole of traction plate, in order to make traction rod 2 not to swing (Figure 3-1)

Traction point can be changed to suitable height by turning traction rod, in order to connect the matched farm machine .

4.1.4 Warm air blower(option)

Tractor upper warm air blower is on the cab front top, warm air blower switch is on the blower, which can make warm air

blower to work when turn on, in order to ensure comfortable work temperature in the cab.

When ventilation is needed in the cab, especially in summer, just Turn on warm air blower after turning off the outlet valve for the warm air blower hot recycling water;At that time, the fan starts to run.

The two small opening doors on right/left side of the warm air blower are used to adjust the direction of air current inside of the cab;

Traction point can be changed to suitable height by turning traction rod, in order to connect the matched farm machine .



Figure 4-1 swing traction application

1. positioning pin, 2. traction rod



Figure 4-2 warm air blower

Important notes

1. Optional parts should be installed under the manufacturer technician's instruction
2. For tractor with warm air blower, engine cooling system must apply anti-freezing liquid in winter.

4.2 Documents, spare parts and facilities provided with the machine

Varieties	Sequence No.	code	description	unit	Quantity	remark
together with the machine technical document	1		Technical document provided with the engine	book	1	From engine matching part factory
	2		quality certificate	piece	1	
	3		Tractor component catalogue	book	1	
	4		Three-commitments warranty after sales service	piece	1	
	5		engine quality certificate	piece	1	From engine matching part factory
	6		Instruction manual for tractor	book	1	
	7		Packing list of parts provide with the machine	set	1	
machine attached piece	1	TC02482010003K	fuse 10A	piece	2	
	2	TC02482010004K	fuse 15A	piece	2	
	3	TC02482010005K	Fuse20A	piece	2	
	3	TC02482010006K	fuse 30A	piece	2	
	4	TS06481010009	fuse 80A	Piece	1	
	5	FT300.38.103	Breather filter core	piece	1	used for chassis breather
	6	FT700.55D.109	Breather filter core	piece	2	for hydraulic breather
	7		Spare part provided with the engine	bush	1	From engine matching part factory
	8	FT65.48.080	Rear trailer bolt	piece	1	lead out connector for trailer rear signal lamp when being used on trailer;
	9	FT654.58.010a	adapter	piece	1	as option, used for the type with simple hydraulic output, non-high-pressure, Metric joint
			piece	4	as option, used for the type with multi-way valve output, non-high- pressure Metric joint	
			piece	5	as option, used for the type with simple hydraulic output and multi-way valve output, non-high- pressure Metric joint	

Varieties	Sequence No.	code	description	unit	Quantity	remark
				piece	2	as option, used for the type with high pressure, Metric joint
	9	FT300.53.102	traction pin	piece	1	as option, just used for the type with two-function trailer
	10	FT300.53.103	Supporting sleeve	piece	1	
	11	FT65.53.103	Elastic lock pin	piece	2	
	12	TB400.96-01	Filter core for air filter	piece	1	as option, used for the type with high pressure,
	13	TG1254.452-18	Plastic split rivet, 6	piece	5	as option, used for the type cab
	14	FT354.38A.030	Adapter male joint	piece	1	as option, used for the type with simple hydraulic output, non-high-pressure, Imperial joint
				piece	4	as option, used for the type with multi-way valve output, non-high- pressure Imperial joint
				piece	5	as option, used for the type with simple hydraulic output and multi-way valve output, non-high-pressure Imperial joint
				piece	2	as option, used for the type with high pressure, Imperial joint

Varieties	Sequence No.	code	description	unit	Quantity	remark
Facilitates provide with the machine	1	GB/T3390.1	Socket for socket wrench, 18×12.5L	piece	1	
	2	GB/T3390.1	Socket for socket wrench, 18×12.5L	piece	1	
	3	GB/T3390.1	Socket for socket wrench, 18×12.5L	piece	1	
	4	GB/T3390.1	Socket for socket wrench, 18×12.5L	piece	1	
	5	GB/T3390.1	Socket for socket wrench, 18×12.5L	piece	1	
	6	GB/T3390.1	Socket for socket wrench, 18×12.5L	piece	1	
	7	GB/T3390.1	Socket for socket wrench, 18×12.5L	piece	1	
	8	GB/T3390.1	Socket for socket wrench, 18×12.5L	piece	1	

Varieties	Sequence No.	code	description	unit	Quantity	remark
	9	GB/T3390.3	Sliding T-handle for socket wrench, H12.5	piece	1	
	10	GB/T3390.4	Extension bar for socket wrench,204	piece	1	
	11	GB/T4388	Double open-end wrench, 8×10	piece	1	
	12	GB/T4388	Double open-end wrench ,13×16	piece	1	
	13	GB/T4388	Double open-end wrench ,18×21	piece	1	
	14	GB/T4388	Double open-end wrench ,24×27	piece	1	
	15	GB/T4388	Double open-end wrench ,30×34	piece	1	
	16	GB/T4388	Double open-end wrench ,36×41	piece	1	
	17	QB/T2349	Slip joint plier 165mm	piece	1	
	18	TD800.96-08	Cross slotted screw driver, 6×150P	piece	1	
	19	QB/T2564.4	Flat screw driver, 1×5.5 125P	piece	1	
	20	JB/T7942.1	Level type oil gun, A200	piece	1	
	21	TD800.96-09	Hexagon socket screw key, 8	piece	1	
	22		Facility provided with the engine	bush	1	from matching part factory

Notes:

1. lead out connector wire when item 7 spare part and accessory for this machine is used on trailer;
2. For the type mounted multi-way valve, mount adapters as option from Item14 spare part provided with the machine according to warehouse entry list,

Notes: Facility, spare part and document provided with the engine

4.3 Wearing part

Consumables for SINOVOL TB series wheeled tractor includes: all bearings listed in appendix 11-4, all oil seals and sealing rings listed in appendix 11-3, all fuses, bulbs, various rubber boot, various glass products and belts used for the whole machine listed in table 4-1

Table 4-1 fuses, bulbs, rubber boot, glass products and belts

Table 4-2 Wearing parts

No.	Code	Name	Quantity/unit	Use location
1	TC02482010003K	fuse 10A	2	Central electrical box
2	TC02482010004K	fuse 15A	2	Central electrical box
3	TC02482010005K	Fuse20A	2	Central electrical box
4	TC02482010006K	fuse 30A	2	Central electrical box
5	TS06481010009	fuse 80A	1	Central electrical box

No.	Code	Name	Quantity/unit	Use location
6	12V-H1-55W	High and low beam two-filament bulb	4	Headlamp
7	12V-1141-21W	Turn signal lamp bulb	2	Handrail lamp and rear tail lamp
8	12V-89-5W	Front position lamp bulb	2	Handrail lamp
9	12V-H3-55W	Working lamp bulb	4/2	Cab (4)/ safety shelf (2)
10	12V -5W	Interior dome lamp	1	Cab interior dome

Important notes:

1. Various spare parts, tools and wearing parts listed above are special parts of this machine, please properly keep and place them to prevent loss for being used by the machine and during maintenance; if lost, the function and use of machine may be affected and its performance will degrade;
2. During maintenance, please use formal accessories required by the manufacturer; if informal accessories are used, the function, service performance and service life may be affected.

5 Maintenance Instructions

A series of technical maintenance measures are taken to clean, check, lubricate, fasten, adjust each part of the tractor or replace some parts regularly. Regular maintenance can avoid technical conditions of each part from deteriorating rapidly, reduce failure rate and prolong its service life, and keep the tractor working in good conditions.

Important notes:

1. All maintenance work should be carried out by the trained and qualified persons, who are familiar with the tractor performances.
2. In order to keep the tractor running in a normal operation and prolong its service life, the technical maintenance regulations should be strictly observed.
3. Within the warranty, if any damage occurs arising from any operator who is unspecialized or not familiar with the tractor performances, or the maintenance which is not made within the specified period from the manufacturer, the relative three-commitment warranty will be invalid.
4. Opening pressure for engine and hydraulic system safety valve, air braking system safety valve, relief pressure for relief valve of constant current relief valve and opening pressure for water tank cover is prohibited to be adjusted without any authorization. Otherwise, it may cause damage to the tractor, and the relative three-commitment warranty will be invalid.

5.1 Technical maintenance regulations

Technical maintenance period for SINOVOL TB series tractor depends on the accumulated work hours, which includes technical maintenance for every shift (every 10 work hours), every 50 work hours, every 200 work hours, every 400 work hours, every 800 work hours, every 1600 work hours, and special maintenance in winter and technical maintenance for long-term storage.

5.1.1 Maintenance for every shift

1. Remove the dust and oil dirt on the tractor, and clean air filter if working under excessive dust.
2. Check and tighten each fastener outside the tractor, tighten them if necessary, especially fastening nut for front/rear wheel.
3. Check the liquid level of engine oil pan, water tank, fuel tank, hydraulic steering oil tank, hydraulic lifter and accumulator, and refill if necessary; before checking oil level of engine oil pan, the tractor should be parked on the ground and the engine does not run for 15 minutes.
4. Fill lubricating grease according to Maintenance Table 4-1
5. Check front/rear tyre pressure, charge it if necessary as required.
6. Check if the tractor has any air/oil/water leakage, if any leakage exists, eliminate immediately.

7. Maintain the diesel engine according to the requirements of daily-shift technical maintenance specified in diesel engine operation and maintenance manual;
8. Check each hydraulic oil pipe whether leaks or not. It should be eliminated if the pipe leaks.

5.1.2 Technical maintenance for every 50 work hours

1. All items for technical maintenance after every shift
2. Fill lubricating grease according to Maintenance Table 4-1
3. Check oil level of oil bath type air filter and remove dust.
4. Check V belt tension of fan, adjust it if necessary.
5. Check and adjust the free stroke of main/auxiliary clutch and driving brake pedal
6. Maintain engine oil filter and oil inlet filter, and clean filter element with diesel oil;
7. Open air discharge plug and oil drain plug for fuel filter, discharge deposited water and impurities.
8. Maintain the diesel engine according to the requirements of level 1 technical maintenance specified in diesel engine operation and maintenance manual;

5.1.3 Technical maintenance for every 200 work hours

1. All items for technical maintenance after every 50 work hours
2. Fill lubricating grease according to Maintenance Table 4-1
3. Replace lube oil in diesel engine oil pan, clean oil pan and filter screen.
4. Replace engine oil filter element, and discharge the air in oil piping after assembly.
5. Clean air filter element and replace engine oil.
6. Maintain the diesel engine according to the requirements of level 2 technical maintenance specified in diesel engine operation and maintenance manual;

5.1.4 Technical maintenance for every 400 work hours

1. All items for technical maintenance after every 200 work hours
2. Fill lubricating grease according to Maintenance Table 4-1
3. Check and adjust gas valve clearance, oil nozzle pressure and atomizing conditions, and adjust them if necessary.
4. Replace the fuel filter element
5. Replace the air filter element (replace it earlier or later according to the dust volume in the working area).
6. Replace engine oil in the casing of fuel injection pump
7. Replace engine oil in gearbox, rear axle, auxiliary box, front drive axle (4-wheel drive), hydraulic lifter and steering system;
8. Check and adjust the toe-in of front wheel

9. Adjust free stroke of steering wheel

10. Flush the accumulator with boiled water and wipe it, check if the specific gravity of electrolyte in the accumulator is lower than 1.24. If abnormal discharge occurs, repair and then charge separately.

11. Maintain the diesel engine according to the requirements of level 3 technical maintenance specified in diesel engine operation and maintenance manual;

5.1.5 Technical maintenance for every 800 work hours

1. All items for technical maintenance after every 400 work hours;

2. Fill lubricating grease according to Maintenance Table 4-1;

3. Remove the dirt between radiating pipes for water tank, and thoroughly clean the diesel engine cooling system.

4. Determine if the cylinder head shall be maintained after dismounting and other items shall be maintained according to the previous operating conditions of the diesel engine.

5. Fasten cylinder head bolts in turn by specified torque;

6. Clean fuel tank

7. Determine if the hydraulic suspension mechanism shall be adjusted or maintained according to its operating conditions.

8. Dismount and maintain the generator once

9. Determine if the starter motor shall be dismounted to check according to its operating conditions;

10. After maintenance, assemble the whole machine and tryout for a short period, check and adjust operating condition of each mechanism.

5.1.6 Technical maintenance for every 1600 work hours

1. All items for technical maintenance after every 800 work hours;

2. Clean and maintain the diesel engine cooling system

3. Replace lube oil in central drive for front drive axle and final drive

4. Check, adjust and maintain the starter motor

5. Maintain the diesel engine according to the requirements of level 3 technical maintenance specified in diesel engine operation and maintenance manual;

5.1.7 Specific technical maintenance in winter

1. Replace lube oil and fuel used in winter

2. When the temperature is lower than 0°C in winter, anti-freezing liquid shall be used;

3. Before every shift operation, the engine shall be started according to the requirements in winter.

4. The accumulator discharge rate shall be not more than 25%, and a higher charge rate shall be often kept.

5. After the tractor stops working, the tractor shall be parked in a warm shed which is warm and wind-proof.

5.1.8 Technical maintenance for long-term storage

1. If the tractor has been stored for less than one month, and the time does not exceed 100 hours since the

engine oil was replaced, special technical maintenance is not required. If the tractor has been stored for more than one month, special technical maintenance shall be done according to Section 5- Storage specified in this Manual.

Table 5-1 SINOVOL TB series Tractor Maintenance

No.	Maintained parts	Operating items	Number of points	Maintenance period
1	Engine oil pan	Check liquid level	1	Every 10h
2	Oil bath air filter	Check liquid level	1	Every 10h
3	Accumulator	Check liquid level	1	Every 10h
4	Hydraulic steering oil tank	Check liquid level	1	Every 10h
5	Radiator (for water tank)	Check liquid level	1	Every 10h
6	Water pump shaft for engine	Fill lubricating grease	1	Every 10h
7	Oil injection pump	Check oil level	1	Every 10h
8	Rear hub	Fill lubricating grease	2	Every 10h
9	Main clutch	Adjust free stroke	1	Every 10h
10	Auxiliary clutch	Adjust free stroke	1	Every 10h
11	Driving brake	Adjust free stroke	2	Every 10h
12	Fan tape	Check tension	1	Every 50h
13	Oil tank for steering	Fill lubricating grease	1	Every 50h
14	Main pin sleeve for front shaft	Fill lubricating grease	2	Every 50h
15	4-wheel drive front axle swing shaft	Fill lubricating grease	2	Every 50h
16	Central swing pin sleeve for front shaft	Fill lubricating grease	1	Every 50h
17	Diesel filter	Replace filter element	1	Every 200h
18	Spin-on engine oil filter	Replace the filter	1	Every 200h
19	Engine oil filter for lifter	Clean or replace filter element	1	Every 200h
20	Oil injection pump	Replace lube oil	1	Every 200h
21	Engine oil pan	Replace lube oil	1	Every 200h
22	Oil pan for oil bath air filter	Maintain and clean	1	Every 400h
23	Drive system and lifter	Check oil level	1	Every 400h
24	Parking brake	Adjust free stroke	1	Every 400h
25	Front wheel	Fill lubricating grease	2	Every 400h
26	Main clutch pedal hub	Fill lubricating grease	1	Every 400h
27	Auxiliary clutch pedal hub	Fill lubricating grease	1	Every 400h
28	Brake pedal hub	Fill lubricating grease	2	Every 400h
29	Center drive for front drive axle	Check oil level	1	Every 400h
30	Main pin oil cup for front drive	Fill lubricating grease	2	Every 400h
31	End drive for front drive axle	Check oil level	2	Every 400h
32	Filter for hydraulic steering oil tank	Clean and maintain	1	Every 800h
33	Hydraulic steering oil tank	Replace lube oil	1	Every 800h
34	Fuel tank	Clean and maintain	1	Every 800h

No.	Maintained parts	Operating items	Number of points	Maintenance period
35	Air inlet/outlet valve for engine	Adjust air valve clearance	8	Every 800h
36	Oil injection pump	Adjust oil injection pressure	4	Every 800h
37	Drive system and lifter	Replace lube oil	1	Every 800h
38	Engine cooling system	Clean and maintain	1	Every 1600h
39	Engine cooling system with anti-freezing liquid	Replace anti-freezing liquid	1	Every 1600h
40	Center drive for front drive	Replace lube oil	1	Every 1600h
41	End drive for front drive axle	Replace lube oil	1	Every 1600h

5.2 Operations for Technical Maintenance

5.2.1 Tractor Maintenance

For maintained parts, operations and maintenance period of SINOVOL TB series tractor, see Table 5-1.

5.2.2 Maintenance

5.2.2.1 Maintenance for common accumulator

- Check the status of accumulator (Figure 4-1)

- Normal level of electrolyte shall be 10~15 mm higher than pole plate. Fill it if necessary.
- For checking method of electrolyte, see the Figure. It

can be made only after the tractor is parked on the ground, the engine flames out and the accumulator is cooled.

- The accumulator should be charged under the following condition:

- --engine starting nerveless or illumination faintly;
- If it is under voltage, measure the terminal voltage when discharging; for 6V accumulator, the voltage is lower than 5.25V; for 12V accumulator, the voltage is lower than 10.5V.
- --when storing with liquid, the accumulator shall be charged monthly. The charging method as follows: charge the accumulator by 0.1C20A (C20 is power capacity for 20h). When the terminal voltage for 6V accumulator reaches $(7.2 \pm 0.05)V$ and that for 12V accumulator reaches $(14.4 \pm 0.05)V$, it is allowed to continue charging for 5h.

- Accumulator Maintenance

- -- accumulator should be stored in a clean, dry and ventilated warehouse, temperature should be within $(0 \sim 40) ^\circ C$ It should be slightly handled, without collision or reverse placing.
- -- do not loose the filling plug before applying dry charged accumulator, in order to avoid dry charge performance loss;
- --do not use well water, fountain water or other water with impurity to confect electrolyte, or refill

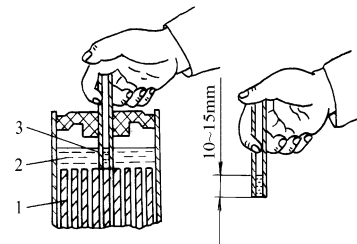

Figure 5-1 Check the status of accumulator

1.Pole plate 2. electrolyte
3. Fine glass tube

them into the accumulator.

- -- accumulator terminal and power connector should be connected tightly, in order to prevent terminal from melting when starting. In order to avoid terminal oxidation or corrosive, the exterior of terminal should be coated with Vaseline.
- --keep the exterior terminal of the accumulator clean, and often check if the exhausting hole on oil filling plug is smooth.
- --regularly check if voltage for the regulator accords with the standard, and, the voltage for the regulator is $(14.2.1\pm 0.2)V$ (Volt);

5.2.2.2 Maintenance of Maintenance-free Accumulator

● State Inspection of Accumulator

Normally the maintenance-free accumulator does not require any special maintenance. To observe the display from the view hole of the liquid densimeter: green - full power; grey-lack of power; dark-no power

- The accumulator should be charged when the inspection hole becomes grey, and it should be replaced when the inspection hole becomes dark.

● Maintenance of Accumulator

- -- accumulator should be stored in a clean, dry and ventilated warehouse, temperature should be within $(0\sim 40)^\circ\text{C}$ It should be slightly handled, without collision or reverse placing.
- The terminal of accumulator and power socket should be connected fixedly, avoiding fusion and erosion when start up, vaseline should be used on the terminals;
- Keep the accumulator outer terminals clean;
- Check the generator output voltage measure up regularly, voltage is $(14.2\pm 0.25) V$.



1
Figure 5-2
1.Hydrometer Inspection
Vent



Note:

1. When charging, keep ventilated and far away open fire. Do not spill electrolyte over body or clothes, in order to avoid accidental hurt.
2. Temperature of electrolyte during charging should be less than $^\circ\text{C}$, if exceeding, in order to avoid accidental danger, charging current should be reduced to a half or charging should be stopped to lower the temperature. Then, the charging time should be accordingly extended.
3. When charging is over, firstly shut off the power to cut off the power and pole, in order to avoid fire or explosion.

5.2.2.3 Hydraulic Steer Oil Tank Inspection and Maintenance

Hydraulic steer oil tank mounted on the right side of engine hood. Open the oil tank cover(with dip stick), inspect if there is any oil mark on the dip stick. If not, it indicates the insufficient oil in the steer oil tank and locate the specific reason for oil leaking, then replenishing the oil to the central mark of dip stick, and reinstall it. The hydraulic steer oil tank, oil pipe and the terminals should be inspected systematically and thoroughly with no oil leaking, otherwise it may result in ineffective steering trouble. The oil tank internal filter should be cleaned or changed regularly.

When checking the oil level, the ventilation hole valve (as rivet style) in the center of the oil tank cover should also be checked at the same time; check if it operates acutely, and clean it if any oil filth affects the operation.

5.2.2.3 Maintenance of oil-bath air filter

1. Loosen the lock catch of wet air filter, and remove the oil basin;
2. Remove the filter element, and wash it with gasoline or kerosene;
3. Pour dirt oil in the oil basin, and wash the oil basin;
4. Add clean diesel engine oil to the oil level line of oil basin. Use 15W/40 oil in summer and 10W/40 oil in winter;
5. Check the sealing part for damage; if any, replace old filter element with new one. Install the filter element that has been cleaned;
6. Install and fix the oil basin, and check that the connection and sealing of intake system is reliable.



Oil-bath air filter
Oil-bath air filter element



Cleaning method of oil-bath air filter

5.2.2.4 Use and maintenance of dry-type air filter

When the filter blockage alarm sends a warning signal, it indicates that the filter element is too dirty, and too dirty filter element can result in power loss or inadequate burning and belching of black smoke due to insufficient intake of engine. To guarantee normal operation of engine, maintenance of filter element is required.

1. Open the hood, and check the filter blockage alarm to understand the working condition of air filter;
2. With the engine stopped, open the buckle, and remove the air filter end cap;
3. Carefully take out the filter element, and clean the inner shell of air filter with the hairbrush;
4. While rotating the filter element, blow all dust outward from the interior of filter element by using compressed air with pressure of less than 500Kpa;
5. Reassemble the cleaned filter element;
6. Align the protruding locating block of air filter end cap with the locating slot of air filter housing, install the air filter end cap, and fasten the buckle after confirming that the installation position is proper;
7. After installation, check whether the impermeability of each connecting point of air filter system housing is good.

- Check dry-type air filter element

1. Put the handheld lamp in the filter element, then carefully check it for small hole, and replace the filter element with small hole;
2. Ensure the outer covering net is free from dent, because the vibration produced by the tractor working room can result in mutual friction of components, if there is dent on the outer covering net, the dent is easy to rub against with surrounding components, thus causing breakage and affect the filtration effect of air filter.
3. Ensure rubber sealing surfaces on both ends are intact; if damaged, timely replace them to ensure good sealing of air filter.

- Replace dry-type air filter element

1. Unlock and uncover the hood upward;
2. Loosen the buckle fixing the air filter cover, and then remove the air filter cover;
3. Remove the dry-type air filter element, and quickly replace it with new one;
4. Adjust the position of filter element, and check whether the filter element and air filter housing are jointed tightly;
5. Align the protruding locating block of air filter end cap with the locating slot of air filter housing, install the air filter end cap, and fasten the buckle after confirming that the installation position is proper;
6. After installation, check whether the impermeability of each connecting point of air filter system housing is good.



Appearance of dry-type



Dry-type air filter blockage alarm



Dry-type air filter element

Important Notes:

1. When performing operation in bad sand and dust weather or performing operations that produce more air suspended solids such as rotary tillage and stubble cleaning, it is suggested to clean the filter element once a day. If the dust on the filter element cannot be cleaned up after maintenance or the filter element is broken, replace the filter element.
2. It is prohibited to use high pressure air to clean the inner shell of air filter.
3. Correct use and maintenance of air filter directly relate to the service life of engine. During farmland operation, check the filter element after operation of every shift to ensure all joints connecting the air filter and engine are well sealed, including all hose fittings and end caps of air filter housing. If any crack is found, immediately repair it. When the tractor is used with the harvester equipped, the use effect will be better if the position of primary filter is raised. During maintenance of dry-type air filter, it is prohibited to flush the filter element with oil and water.

Check the air intake system

Check whether the clamps of air intake system and engine intake pipe are tightened. Check all hoses for crack because crack will cause system leakage or failure; if necessary, make replacement.



Dry-type air filter engine clamp

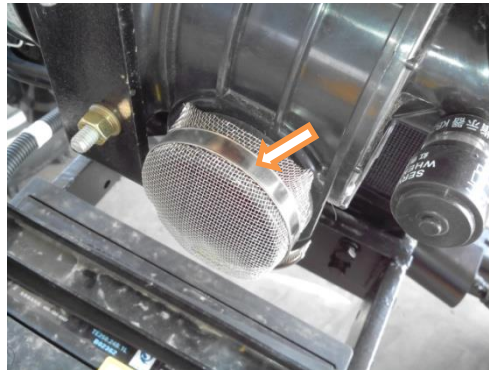

Dry-type air filter intake system clamp



Dry-type air filter intake system clamp



Oil bath air filter clamp

5.2.2.6 Fan adhesive tape tension degree adjustment

Press the fan adhesive tape central part with thumb, push a pressure of (29.4~49.0) N, press distance (15±3) mm, if not meet the requirements, it should be adjust as follow:

Release the fixing nut on the generator adjusting bracket, pull the generator inside out, make the adhesive tape tense, and then screw down the fixing nut on the generator bracket.

5.2.2.6 Oil level inspection and oil change for engine sump

Check the engine oil level

Maintenance interval should be every day or every ten hours

- 1、 If the engine is in shut down state before checking the engine, make it idle for 2-3 min and then wait for 2-3 min after it is shut off to let the oil return to oil sump.
- 2、 If the engine is in operation state before checking the engine, make it idle for 2-3 min and then wait for 2-3 min after it is shut off to let the oil return to oil sump.
- 3、 Check the engine oil gauge. Wipe the oil gauge and insert it again and then pull it out to read the oil level.
- 4、 The safety using scope is within the area with crossing line. When the oil level is lower than the mark, the vehicle is not allowed to be started. Fill oil with proper viscosity in the filling hole along with season change.

Replace engine oil and oil filter

- 1、 Operate the engine to heat the oil and after the oil temperature reaches 50°C ~ 60°C shut down the engine;
- 2、 Remove the oil drain plug to drain the oil;
- 3、 Replace the oil filter when replace the oil. Apply oil onto the sealing ring of new oil filter and mount it on. After tighten it with hand, use tool the screw it with 1/2 circle;
- 4、 Tighten the oil drain plug;
- 5、 Fill oil with proper viscosity along with season change.



1. Engine oil gauge
2. Engine oil filter

5.2.6 Oil level check and oil replacement of engine oil sump

Pull out the oil gauge at front left of engine oil sump, and check whether the level is between upper and lower scale. If the oil level does not reach the lower scale, please remove the oil filling cover on engine timing gear chamber cover to fill oil.

During maintenance, remove the oil drain plug at bottom of oil sump to discharge dirty oil and clean it, and then refill new oil.

5.2.2.8 Front Axle Maintenance

According to the maintenance requirements, add lubrication oil on king pin tube, front axle central swivel pin tube, steering oil tank ball joints and tie rod ball type, check if the tie rod ball type nut and two ends of oil tank pin nuts were loose.

5.2.2.9 Oil Filter Maintenance

Lifter oil filter was located on the lower part right side of engine. Maintenance will be kept with the technical requirements. Methods listed as follow: turn on the oil filter rear cover, take out the strainer filter, clean with gas and blow with compressed air. When the filter element could not be clean or worn out, it should be replace with a new filter element.

5.2.2.10 Power Train Maintenance

When checking oil surface, parking the tractor on a flat ground, extinguishing the engine, take out the dip stick of the lifter front part and rear axle, wipe up, then insert the dip stick. If the oil surface lower than the lower mark, filling the lub oil till the oil surface locates between the upper and lower marks (measure filling lub oil after 5min). When changing lube oil, the drain plug 1 in the transfer box should be removed, to completely drain used oil, put oil drain plug and tighten, then fill fresh lube oil.

5.2.2.11 Lifter Maintenance

Parking the tractor on flat ground, descending lift arm to the minimum location, extinguishing engine, taking out the lifter cover dip stick, check the oil surface height. If the surface is under the lower mark, filling the oil till it locates between upper and lower marks. Drain used oil when changing hydraulic oil and then fill fresh lube oil.

5.2.2.12 Fuel Tank Maintenance

Parking the tractor on flat ground, extinguishing engine, take off the drain plug on the fuel tank drain the used oil in the bottom.

Oil tank functions reserve oil, subside wet and impurity. Clean regularly during using process.

5.2.2.13 Engine Cooling System Maintenance

Cooling fluid of engine could either be the tap water or antifreeze. The valid date for antifreeze is 2 years or more, replacing and cleaning the cooling system if excess the date, then fill with fresh antifreeze.

Cooling system scale cleaning: before maintaining, add 750g caustic soda and 150g kerosene in every 10L water then fill them into the cooling system. Running the engine in medium speed for(5~10)min, keep for(10~12)h(reserve the heat and avoid freeze in winter), then start up the engine in the medium speed for 20 min, then stop and drain the cleaning fluid.

After the engine cooled down, unbolt the water release valve at the bottom of water tank. Clean the water tank with the water pipe, check the water tank buffer regularly, if it got aging replace a new water tank for fear of shorten using life. Turn off the water releasing valve, running the engine for several minutes. After the engine cool down, add new antifreeze or cooling water.

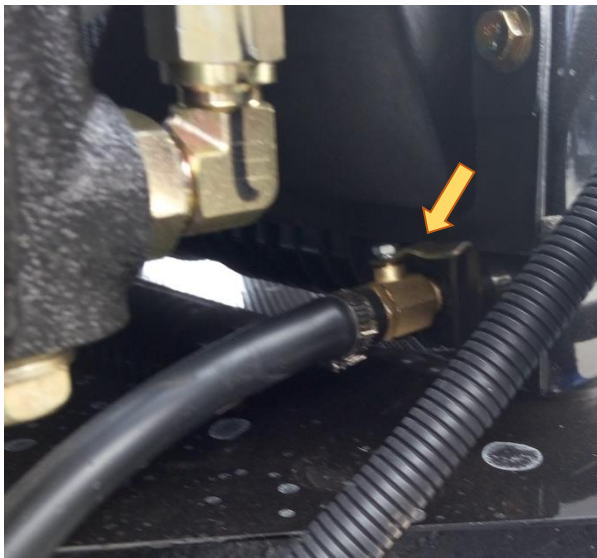

Water drain valve of water tank



Water drain valve of cylinder

Important notes:

- 1、 Caution: before the coolant cools down, never remove the radiator cover or coolant. Remove the radiator cover only after the coolant cools down. When remove the radiator cover please release it slowly to discharge the residue pressure.
- 2、 Never fill cold water into engine cooling system; otherwise it will cause cylinder or cylinder cover generating cracks. Never start the engine without being filled with coolant; otherwise it easily cause cylinder explosion due to engine combustion chamber.
- 3、 Automatic temperature regulator must be removed thus to ensure it is thoroughly cleaned.

Front engine hood net, side net, radiator and oil cooler cleaning

- 1、 Once the front engine hold net is blocked, clean it at once; during cleaning, please use compression air with pressure lower than 210Kpa (2bar), and ensure there is no spectator nearby. Please wear protection articles and goggles, in case of the splashing debris causing injury.
- 2、 Open the hood to check whether the radiator is blocked by sundries, and if there is, please use brush or compressed air to clean it;
3. If it needs more thorough clean, please use compressed air or water to clean from rear part of radiator, and correct the burned radiator fin straight.
4. Hood external appearance



Check whether there is leakage at cooling system

Maintenance interval: 250 h.

- 1、 Check the surrounding bottom of upper water chamber of water tank to see whether there is air bulb or other places possibly having coolant leakage.
- 2、 Check the shim at thermostat external case to see whether there is coolant leakage.
- 3、 Check the cooled reservoir to see whether there is oil leakage or leakage mark.

Check coolant level

- 1、 Check the coolant level in reservoir to see whether the level is between two scales.
- 2、 If the level is lower than lower scale, please fill coolant into reservoir until it reaches to upper scale.

5.2.2.13 Fuel system air evacuation

When the fuel system needs to be disassembled (fuel pipe is disconnected or the filter is removed) due to tractor long time parking or due to service, and when the fuel tank is emptied, air may enter into fuel pipeline. Air in fuel system would cause difficult engine starting. In order ensure normal operation of engine, fuel system must have air evacuation.

- 1、 Full fill the fuel tank and ensure the fuel pipeline is at engagement position;
- 2、 Firstly release the fuel filter air relief plug; pull the draw knob B of fuel deliver pump up and down, until there is no air bulb when diesel flows from air relief hole;
- 3、 And then release the fuel filter air relief pug and release fuel injection pump air relief plug;
- 4、 pull the hand pump draw knob B of fuel deliver pump up and down, until there is no air bulb when diesel flows from air relief hole and then release the fuel injection air relief pug



Hand fuel pump

Discharge the water and sediment from diesel filter

Maintenance interval: 10 h

- 1、 Place the main gear shift lever at neutral position, and then set the parking braking after interlocking the left and right brake pedal;
- 2、 Place the hand throttle at the lowest position, and make the engine idle for 1-2 min and then shut down the engine;
- 3、 Open the drain outlet of fuel filter, and discharge the deposited water and settlement into a container. When there is clean fuel flowing out, tighten the outlet.

Replace the diesel filter

Maintenance interval:100 h

- 1、 Thoroughly clean diesel filter and surrounding part;
- 2、 Remove the diesel filter;
- 3、 Check whether the filter seat is clean. And clean it as necessary;
- 4、 Thoroughly check the sealing ring of filter seat. And replace it when necessary;
- 5、 When replacing diesel filter, fill clean diesel into diesel filter and apply a layer of lubricant onto sealing ring of the filter. Make sure install the diesel filter within 15 min after applying the lubricant;
- 6、 Install the new filter element onto fixing seat, and then tighten 1/2—3/4 circle. Never make the lock ring too tight, otherwise the thread and sealing ring would be damaged;
- 7、 Diesel system air relief.

5.2.2.15 Generator Maintenance

1. Maintain the generator every 1000hours, the maintaining methods as follows:
2. check if generator fixing nut is firmly fixedly, if the cable insulation worn out, if the cable connections are reliable with no breakage.
3. Check the communtor and electric brush when tractor works every 1000h, if the communtor surface erosion seriously, furbish with sand paper. If worn out or smash Electric brush should be changed a new one. Add lub oil on the shaft sleeve and other function parts.

Important notes:

- 1 In winter, in accordance with the temperature, check the thickness of antifreeze, if out of place, recover the normal thickness. As to tractor with no antifreeze, when temperature fall below 70°C, drain the water during the idle speed, avoiding cooling water freeze to split.
- 2 Engine must use the high grade light diesel, light diesel fuel No. 0 in summer, light diesel fuel No.10 in

Winter. The diesel must be clear, subside and purified at least 48 hours.

- 3 Type ZHB fuel injection pump should check the lub oil surface, fill lub oil to the mark location if lacking, change lub oil when engine keeps working for 200h. Lub oil used in fuel injection pump is same with the lub oil used on diesel engine.

Important notes:

1. when starting up, check if the cooling water in the radiator is full. Check if there is any leakage. Radiator cover is fasten or not.
2. Check the radiator core part regularly clear the weed, dust and grease etc.
3. Clear scale in the cooling system regularly, make sure the radiator function effectively.
4. Check the thermostat performance regularly, otherwise it may influence the cooling water circulation and fall the cooling effect

5.3 Tractor Chassis Adjustment

a) Dual clutch adjustment of non-independent operating flat floor machine

Dual clutch adjustment includes adjustment of main clutch and auxiliary clutch.

➤ Adjustment of main clutch

1. Clearance between main clutch release lever and release bearing end is of (2~2.5) mm, and height difference among 3 release lever ends should not be more than 0.2 mm.

Adjustment is the same with 1.4.2.1 Dual clutch adjustment of non-independent operating flat floor machine.

2. Clutch pedal free stroke is of (20~25) mm.

Adjustment is the same with 1.4.2.1 Dual clutch adjustment of non-independent operating flat floor machine.

3. Total stroke of clutch pedal is of (185~195) mm

Adjustment: release the lock nut (No.1), and adjust the bolt entering depth to make total stroke of clutch pedal is of (185~195) mm, and then adjust the lock nut.

➤ Auxiliary clutch adjustment

Distance between main clutch release lever and auxiliary clutch release lever should be 8 mm, and height difference between auxiliary clutch release lever ends should not be more than 0.2 mm.

Adjustment is the same with that of dual clutch of non-independent operation flat floor machine.

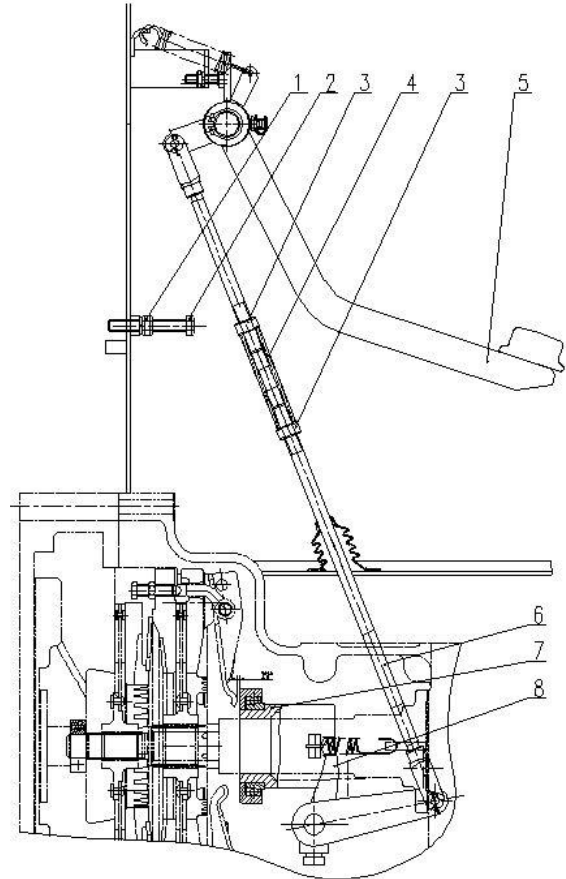

Fig. 5-3 Dual clutch

- | | | |
|--------------------|-----------------------------------|------------------------|
| 1. Lock nut | 2. Bolt | 3. Lock nut |
| 4. Connection rod | 5. Clutch pedal combination piece | 6. Pull rod welding-on |
| 7. Release bearing | 8. Clutch rock shaft | |

b) Independent operation mechanism dual clutch adjustment

Dual clutch adjustment includes main clutch adjustment and auxiliary clutch adjustment.

➤ Main clutch adjustment

1. Clearance between main clutch release lever and release bearing end is of (2~2.5) mm, and height difference among 3 release lever ends should not be more than 0.2 mm.

Adjustment: adjust the screw's (No.5) entering depth to make clearance between main clutch release lever and release bearing end is of (2~2.5) mm, and height difference among 3 release lever ends should not be more than 0.2 mm.

2. Clutch pedal free stroke is of (20~25) mm.

Adjustment: release the lock nut (No.12), and adjust the pull rod and change the pull rod length to make total stroke of clutch pedal is of (25~35) mm, and then firmly lock the lock nut on the pull rod.

3. Total stroke of clutch pedal is of (140~155) mm

Adjustment: release the lock nut (No.22), and adjust the bolt (No.21) entering depth to make total stroke of clutch pedal is of (140~145) mm, and then adjust the lock nut.

➤ Auxiliary clutch adjustment:

1. Clearance between auxiliary clutch release lever end and release disc face is of (2~2.5) mm, and height difference among 3 release lever ends should not be more than 0.2 mm.

Adjustment

release the lock nut (No.1) to make clearance between auxiliary clutch release lever end and release disc face is of (2~2.5) mm, and height difference among 3 release lever

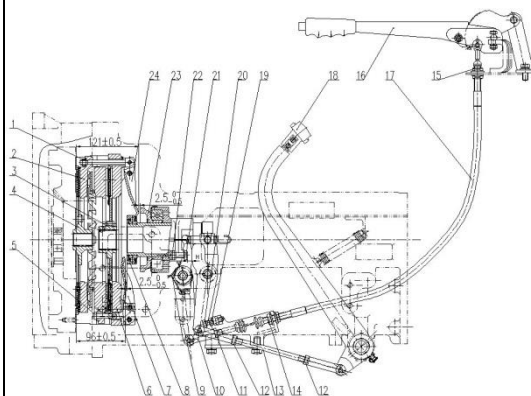

Fig. 5-4 Clutch operation mechanism assembly

1. Adjusting nut
2. Auxiliary clutch pressure plate
3. Main clutch friction plate assembly
4. Auxiliary clutch friction plate assembly
5. Adjusting screw
6. Main clutch pressure plate
7. Main clutch release lever
8. Main release bearing
9. Main clutch release rocker arm
10. Pull fork
11. lock nut
12. lock nut
13. Pull rod
14. lock nut
15. lock nut
16. Auxiliary clutch operation handle
17. Auxiliary clutch flexible axle bracing wire
18. Main clutch pedal
19. Adjusting bolt
20. lock nut
21. Adjusting bolt
22. lock nut
23. Auxiliary clutch release disc
24. Auxiliary clutch release lever

<p>ends should not be more than 0.2 mm.</p> <p>2. Total stroke of auxiliary clutch operation handle is of (45~55) mm</p> <p>Adjustment: Release the lock nut (No.11), and change pull rod fork (No.13) thread entering length, to make auxiliary clutch operation handle's free stroke is of (45~55) mm, and then lock the lock nut on pull rod fork.</p> <p>3. Auxiliary clutch operation handle is of (185~235) mm.</p> <p>Adjustment: release the lock nut (No.19), and adjust bolt (No.20) entering depth, thus to make free stroke of auxiliary operation handle is of (185~235) mm, and then tighten the lock nut.</p>	
--	--

<p>Important notes:</p> <p>(1) To avoid friction disc contaminated by oil, please often loosen drain plug under fly wheel case to discharge the oil leaked from engine and transmission. If there is serious oil leakage, please timely find out the cause and solve the problem. When necessary, please use petrol (or kerosene) to clean friction disc.</p> <p>(2) To prevent and avoid the over wear on friction disc, please regularly maintain and adjust the clutch; during operation, please do not frequently disassemble and assemble clutch; when engage the clutch, please step down the clutch pedal quickly, never make it work under semi-engagement, in case damaging clutch.</p> <p>(3) Never operate when the clutch adjustment is not good, as this would accelerate clutch friction disc wear even make it burned.</p> <p>(4) During assemble the clutch, please fully apply the lithium grease in Bearing 1 (see Fig. 2-3) and release bearing seat 5 (see Fig. 2-3) inner chamber. When disassemble the clutch, please check whether the Release bearing 5 lacks oil. If it lacks oil, please put it into heated molybdenum disulfide lithium grease to make the grease go into bearing, and take it out after the grease cools down. Do not put the</p>
--

release bearing into petrol or diesel for cleaning, in case the grease in bearing being removed. Otherwise the grease must be reapplied.

Flat floor machine type

Brake pedal working stroke is of 90~120 mm, and parking brake handle stroke is of 200~230 mm.

After the brake friction disc is worn, brake pedal working stroke will increase, and it will case bad brake performance, therefore it should be adjusted.

As showed by Fig. 5-8: loosen the lock nut (1), and adjust the

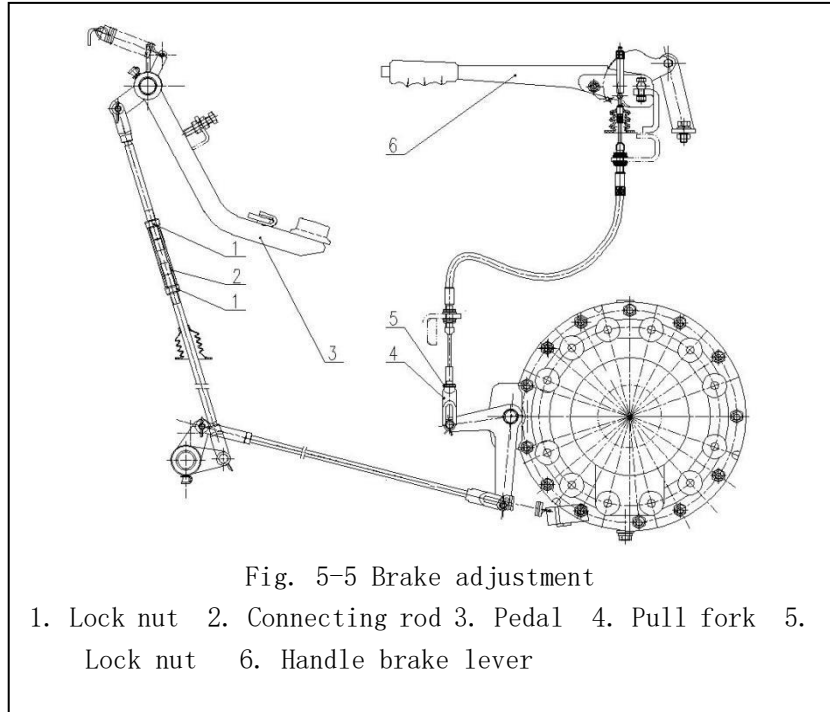

Fig. 5-5 Brake adjustment

1. Lock nut 2. Connecting rod 3. Pedal 4. Pull fork 5. Lock nut 6. Handle brake lever

connecting rod (2), thus to make working stroke of brake pedal reach to 90~120 mm and make left and right pedal have same working stroke. After adjustment completion, tighten the lock nut. Loosen the lock nut (5), and change the pull fork thread entering depth, thus to make the handle brake working stroke is within 200~230 mm. When left and right braking distance is different, it needs to adjust left and right adjusting pull level and pull fork separately



Note:

Right/left pedal free stroke should be adjusted to the same. Otherwise, when emergency braking, hazard accident may occur because the tractor maybe suddenly deflex to one side. For the sake of safe, carry out braking test after brake operation mechanism adjustment, as follows: interlock right/left braking pedal, drive the tractor on dry and flat road, brake in emergency after releasing main clutch when running at high speed and in a straight line, then, stop to check the sliding trace on the road surface. If the trace of right and left drive wheel on the road is consistent, such as the trace on the two sides is in a straight line, parallel and equally long, it means that the adjustment is suitable. Otherwise, It needs readjustment. If it is still not good even after readjustment, the brake should be checked from interior.

6.5.3.5 Structure of rear axle and adjustment

Rear axle is composed of center drive, differential, differential lock and PTO shaft. (Figure 5-6)

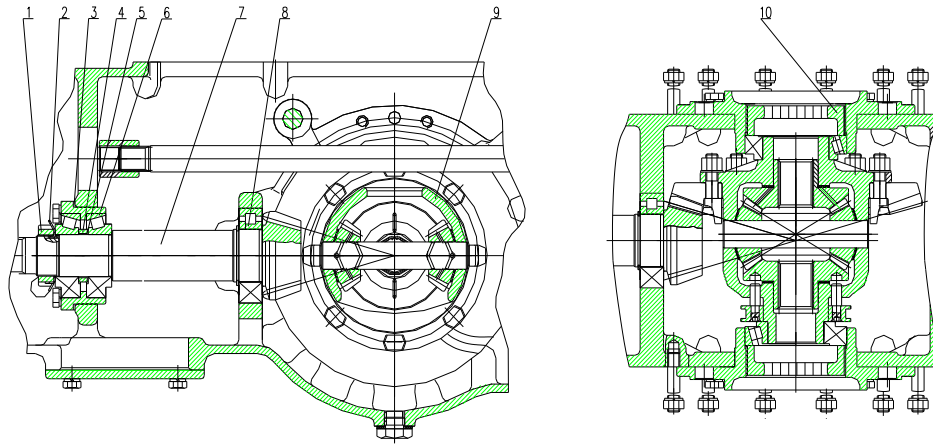

Figure 5-6 Structure of Rear Axle and Its Adjustment

1.round nut 2.locking gasket 3.adjusting gasket 4.spacing sleeve 5. adjusting gasket 6. conical roller bearing 7.bevel pinion shaft 8. cylindrical roller bearing 9.differential 10.adjusting nut

5.3.5.1 Structure of rear axle

Center drive is composed of a pair of spiral bevel gears. Back end of bevel pinion shaft is supported by conical roller bearing; its front end is supported by internal cylindrical roller bearing; and its shaft end spline links with transmission spline.

5.3.5.2 Major adjustment of rear axle

- Adjustment of bevel pinion bearing (Figure 5-6)

Two conical roller bearings on the bevel pinion shaft are pretightened. During using, axial clearance may occur in the bevel pinion and pretightening force may reduce due to worn bearing; thus, you should check it regularly (when every 3 class maintenance) and readjust. When adjusting, measure the width A between two bearings, then, apply 350N axial force on it, and measure the width B between two bearings after distortion; choose adjusting gasket, whose thickness is $\delta=A-B$, install it in the original position. After adjustment, tighten the round nut, and lock with gasket.

- Adjustment of differential bearing (Figure 5-7)

Left/right bearing of differential are also pretightened. During using, axial clearance may occur in the large conical gear and pretightening force may reduce due to worn bearing; thus, you should check it regularly (when every 3 class maintenance). When adjusting, tighten the left/right adjusting nuts (Figure 5-6), and keep the axial pressure of the bearing at about 350N.

- Engagement adjustment of central bevel gear (Figure 5-6)

During using, the increasing gear backlash caused by worn gear will not interfere with normal work of the gear. While the bevel gear separates from the originally engaged position due to worn bearing, generally speaking, as long as it would not interfere with normal work of the gear, it may not be adjusted during operation; but when performing overhaul and the gear cannot work normally or replacing bearing (differential bearing and bevel pinion bearing) and bevel pinion shaft, you should adjust engagement (it should be after the pretightening adjustment of the bearing).

- Check gear backlash. Insert the lead sheet into the intertooth spaces of non-working surface of large conical gear and bevel pinion, turn the gear and squeeze the lead sheet. Then, take out the lead sheet, and measure the thickness of the big end (i.e. gear backlash) leant against the gear, it shall be within (0.15 to 0.3)mm. Thus, it is better to measure 3 points equally around the gear circle, and variation of backlash shall not be more than 0.1mm. If the engagement clearance does not meet the requirements, you could turn adjusting nut to make adjustment; and the sum of the adjusted quantity of left/right

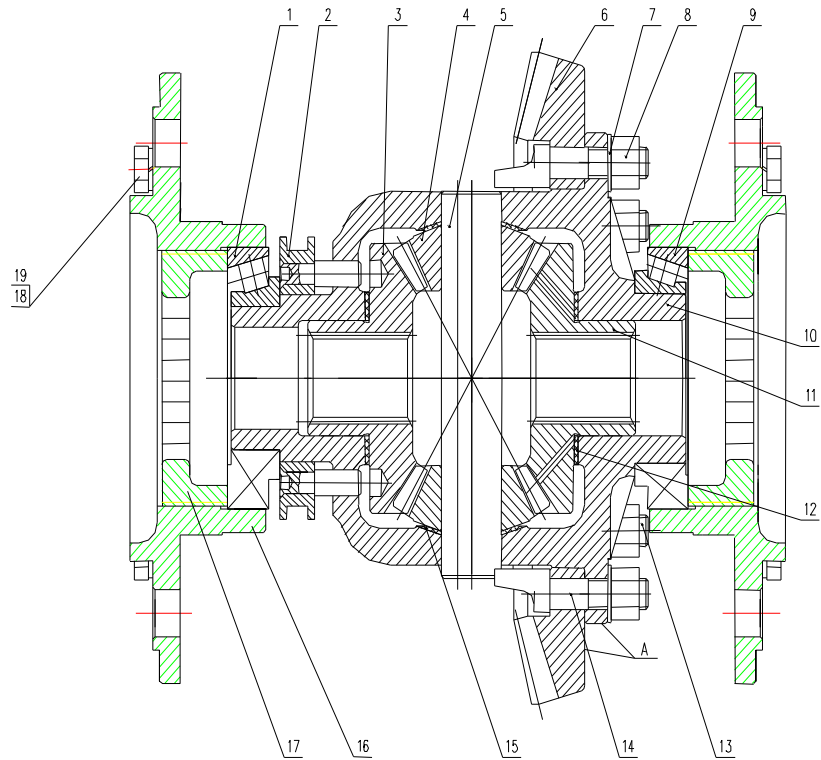

Figure 5-7 Adjustment of Differential Bearing

- 1.bearing7211E 2.differential lock assembly 3.gear of left half axle
4. planetary gear 5. planetary gear shaft 6. large conical gear
- 7.locking gasket 8.nut 9.bearing 2007113 10.differential housing
11. gear of right half axle 12.half-axle gear gasket 13.fixing bolt for large conical gear
- 14.thrust bolt for planetary gear shaft 15. planetary gear gasket 16. differential bearing seat 17.adjsuting nut 18.bolt M10×25 19. washer 10

adjusting nuts shall be zero.

- Check meshing mark. Smear the tooth surface of large conical gear with catsup thinly and evenly. When going forward, the concave of the bevel pinion suffers the force. Smear the catsup over tooth surface of the large conical gear; turn the gear, and you will get the meshing mark on the bevel pinion. The correct meshing mark shall be near the pitch cone in the middle of the tooth height and a little bit near the small end and at a distance of no less than (3 to 4)mm, whose length shall not be less than 60% of the tooth length and height not be less than 50% of tooth height. When adjusting, make the bevel pinion move axially and turn the adjusting nut, and make the large conical gear move axially to get the correct meshing mark by means of changing the thickness of the adjusting gasket. In order not to damage the pretightening of the differential bearing, the sum of the adjusted quantity of left/right adjusting nuts of the differential shall be zero. (Figure 5-6)。

During adjustment, when the engagement clearance conflicts with the meshing mark(i.e. meching mark is proper, while the clearance is not), the meshing mark shall prevail, but the engagement clearance shall not be less than 0.15mm.

Large conical gear (Figure 5-7) is fixed on the differential housing with 6 bolts and 2 thrust bolts of planetary gear shaft. Both ends of the differential housing is installed with conical roller bearing, via differential and bearing seat, and installed on the rear axle housing with 6 screws. There are 2 planetary gears and 2 half-axle gears intalling in the differential housing. The gaskets are installed between the planetary gears and half-axle gears and between half-axle gears and differential housing. The planetary shaft is sheathed with planetary gear sleeve. One end of the planetary gear shaft is with notch to avoid turning and rippling of the planetary shaft.

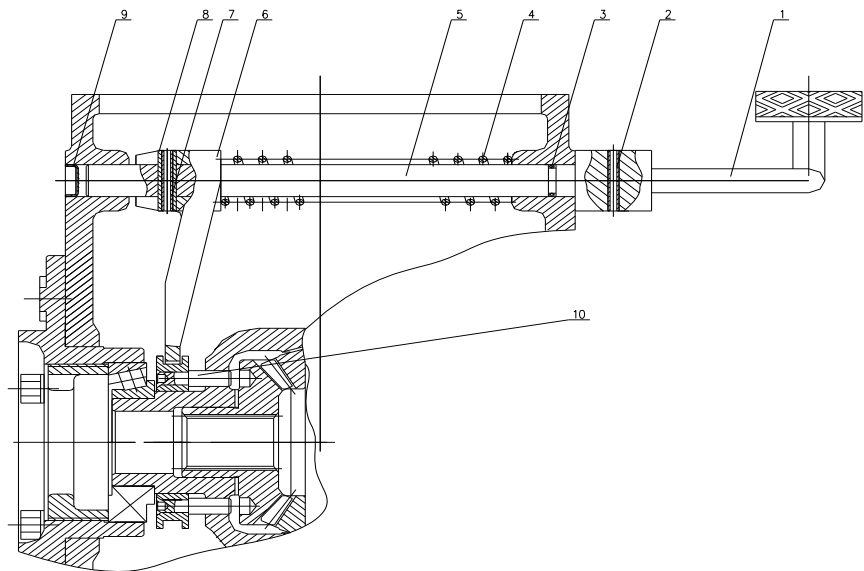

Figure 5-8 Operating Device of Differential Lock

1.welding assembly of lock pedal 2.spring pin 3.O ring seal 4.return spring of differential lock 5.declutch shift shaft of differential lock 6.shift fork of differential lock 7. spring pin 8. spring pin

The operation device of differential lock is located at the right side of the tractor(Figure 5-8) and is composed of differential lock pedal, shift shaft, shift fork, return spring, differential lock and so on.

5.3.5 Structure of final drive and its adjustment

5.3.5.1. Structure of final drive (Figure 5-9)

Final drive adopts planetary gear mechanism drive. The whole planetary gear mechanism is composed of driving sun gear, fixed gear ring, driven planet carrier and planetary gear. The sun gear and half-axle are integral, front spline links with half-axle gear, and gear ring is fixed between the drive shaft housing and brake housing. 3 planetary gears engaged with the sun gear and gear ring are installed on the planet carrier through needle roller bearing and planetary shaft. The drive shaft is supported by 2 annular ball bearings in the drive shaft housing; the drive shaft is linked

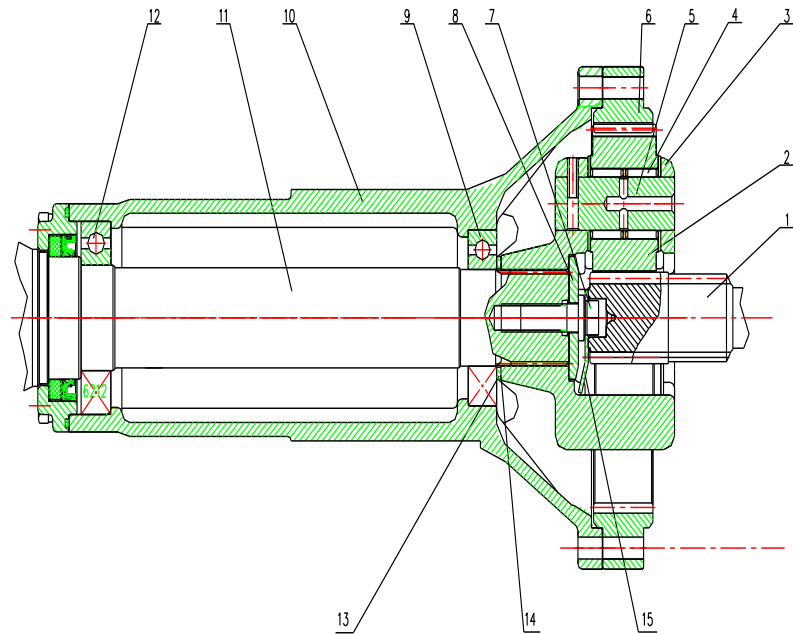

Figure 5-9 Structure of Final Drive

- 1.sun gear 2.planetary gear 3.planet carrier 4.needle roller
5.planetary gear shaft 6.gear ring 7.screw 8.spacer 9.rolling bearing
10.drive shaft housing 11. drive shaft 12. rolling bearing
13. spacer 14.adjusting gasket 15.lock plate

with the planet carrier by means of spline and tightened with locking screw of the drive shaft. In order to change the engagement condition between the sun gear and planetary gear and to average the load distribution when engaging, the sun gear is without fixed supporting and with the status of floating, and there is $G=(0.2 \text{ to } 0.3)\text{mm}$ floating clearance between the planet carrier and spacer.

5.3.5.2 Adjustment of final drive

The clearance $G=(0.2 \text{ to } 0.3)\text{mm}$ between the planet carrier and spacer has been adjusted; and not necessary to adjust during operation. But when performing overhaul or replace the planetary mechanism, it is necessary to be adjusted. When adjusting, measure the distance A from the end face of the drive shaft to the bearing firstly, then measure the depth B of the spline hole of the planet carrier and thickness C of the spacer; choose the thickness $\delta=A-(B+C+0.2\sim 0.3)$ mm of the adjusting gasket, and put the gasket with above thickness on the location as shown. Then tighten the locking screw of the drive shaft and lock it with lock place of the drive shaft.

5.3.5 Front shaft structure and adjustment

5.3.5.1 Front shaft structure (see Fig. 5-10)

Tractor front shaft is tubular front shaft by which the tread can be adjusted, and it is placed in front of diesel engine. The bracket is connected with diesel engine by 6 bolts, and pendulum shaft is supported by front and rear end of bracket. There is sleeve pipe welding assembly on pendulum shaft. On both sides of sleeve pipe, there are 3 bolts fixing left and right auxiliary sleeve pipe assembly.

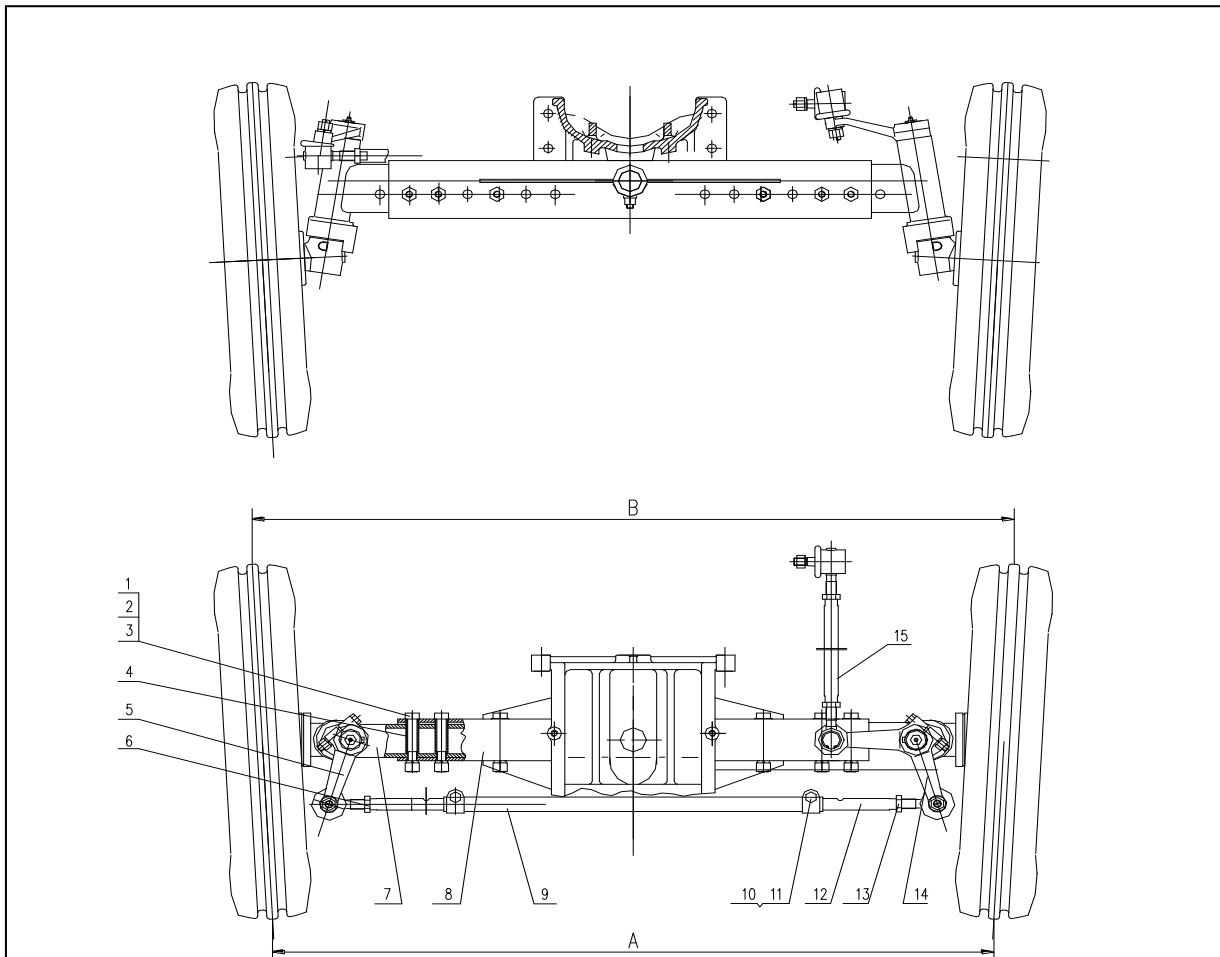

Fig. 5-10 Front shaft structure

1. Bolt 2. Nut 3. Gasket 4. Cushion cover 5. Right steering arm 6. Right-handed nut
7. Auxiliary Sleeve pipe 8. Sleeve pipe 9. Tie rod 10. Bolt 11. Nut 12. Left tie rod 13. Left-handed nut 14. Left steering arm 15. Vertical pull rod

5.3.5.2 Front shaft adjustment

- Front wheel bearing axial clearance adjustment (Fig. 5-11)

Normal front wheel bearing axial clearance is of 0.05~0.15 mm. During operation, when the clearance reaches to 0.4 mm, it should be adjusted. During adjustment, firstly support the front wheel which should leave the ground, and then disassemble the bearing cover and pull out cotter pin. After tightening the castle nut until the bearing clearance disappearing, return the castle by 1/30~1/10 circle, and then insert the cotter pin firmly, and then put on the bearing cover.

- Front wheel toe-in adjustment:

When tractor works for 500 h or when there is obvious swing and when the front tiers wear is too fast, the front wheel toe-in should be checked. And the correct toe-in should be 4~8 mm, and when it is exceeded the front wheel toe-in should be checked. Adjustment: park the tractor on flat ground, and place the steering wheel at neutral position, and make both front wheels in straight running direction, and then loosen the tie rod's left and right lock nuts. And then rotate the tie rod. Measure the front ends and rear ends distance from middle point of tire width at same height of front wheel axis, and make the difference be $B-A=(4\sim 8)\text{mm}$. after adjustment, tighten the left and right lock nut.

- Front tread adjustment

Use internal and external sleeve type, and use telescopic line to adjust tread. Adjustment scope is of (1150~1450)mm. Each step clearance should be 100 mm. During adjustment, firstly release the front-axle beam's inner arm fixing nut, and pull out fixing bolt, liner, tie rod fixing nut and fixing bolt, and then move the auxiliary sleeve and auxiliary tie rod to required position, and then use bolt and nut to fix them.

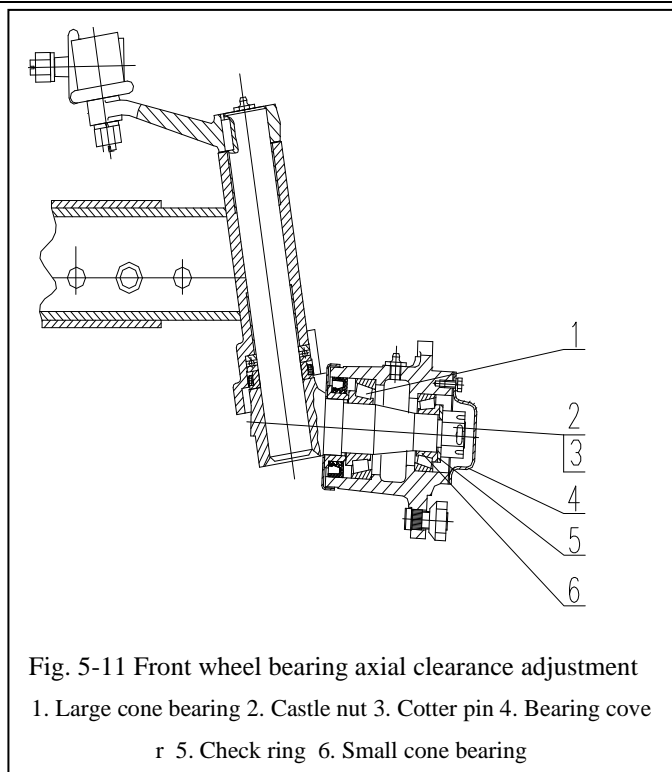

Fig. 5-11 Front wheel bearing axial clearance adjustment

1. Large cone bearing 2. Castle nut 3. Cotter pin 4. Bearing cover
5. Check ring 6. Small cone bearing

5.3.7 Structure of steering gear and its adjustment

5.3.7.1 Marles mechanical steering gear

- Structure:

Marles steering gear is used, and tightened on the transmission housing by 4 bolts. The angle between the steering shaft and the longitudinal axis of the tractor is 65° , and its structure is as shown in Figure 5-12. Steering shaft with the worm assembly is installed in the steering gear housing and supported on the bearing 977907 which is installed in the steering gear housing. Pitman arm shaft is installed on the steering housing with lining assembly, its left end supports on the lining, and its right end is supported on the bearing 205 which is installed on the steering gear side cover of the steering housing. Thus, the roller on the pitman arm (bearing 776701) is engaged with the worm.

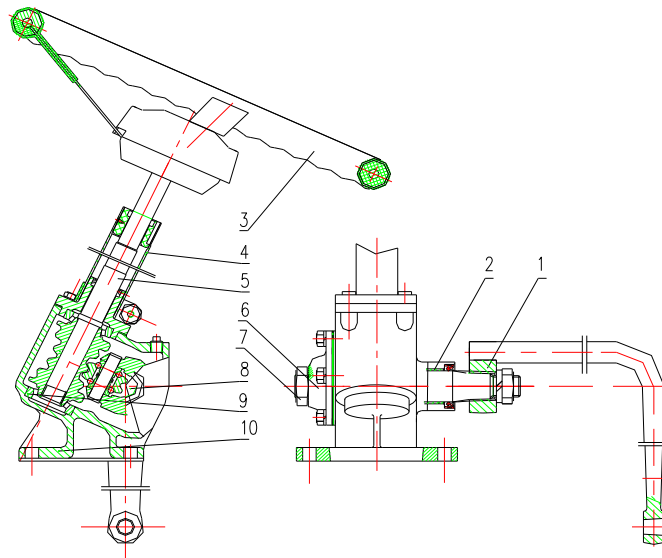

Figure 5-12 Structure of **Marles** Steering Gear

- 1.pitman arm 2.lining 3.steering wheel assembly
4.steering sleeve 5.steering shaft with screw assembly
6. steering gear housing side cover 7.nut 8.steering pitman arm shaft 9.bearing 977907 10.steering gear housing

Thus, the roller on the pitman arm (bearing 776701) is engaged with the worm.

- Adjustment:

The worm bearing shall be pretightened when installing steering gear. The pretightening method is: increase/reduce the adjusting gasket between the steering housing and the lower cover of the steering gear; tighten 4 bolts of the lower cover of the steering gear, and the the lower cover of the steering gear compacts the bearing. The pretightening level of the worm bearing is: the force for turning the steering wheel shall be within (2.5 to 5)N at a distance of 210mm from the radius of the steering wheel without pitman arm shaft or roller. The distance between the centerlines of the roller and the worm shall be 6mm to adjust the engagement clearance between them. When adjusting, unscrew the adjusting nut on the right, use the special spanner to turn the adjusting screw of pitman arm shaft to make the pitman arm shaft move axially in the direction of left and right. Apply the force of (8 to 13) N on the tangent of the position which is 210mm to the radius of the steering wheel, and check when turning the steering wheel to the left/right of 200° from the center position. When the rollers of the pitman arm shaft are located at the two ends, the allowed engagement clearance of the steering gear assembly equals to the range of 30° racing of the steering wheel. When the roller of the pitman arm shaft is at the center position, the steering wheel turns to the left/right within 45° respectively, and the steering gear assembly is not allowed to have engagement clearance.

5.3.7.2 Recirculating ball-rack and sector mechanical steering gear

- Structure:

The steering gear adopts recirculating ball-rack and sector. It is composed of steering shaft, steering screw, steering arm shaft and steering gear housing, etc (Figure 5-13). The steering screw is install on the housing by 2

conical bearings 32206. When turning the steering wheel, it will make the steering screw turn and the steering nut move up and down by 2 rows of steel balls. The racks on the steering nut push the sector and make it turn, thus, make the steering arm swing forward and backward. The steering arm supports in the steering housing, and its axial position is fixed by adjusting nuts.

The steering gear is with an oil refiller. It shall be filled up with dual purpose oil for transmission and hydraulic system to ensure lubrication.

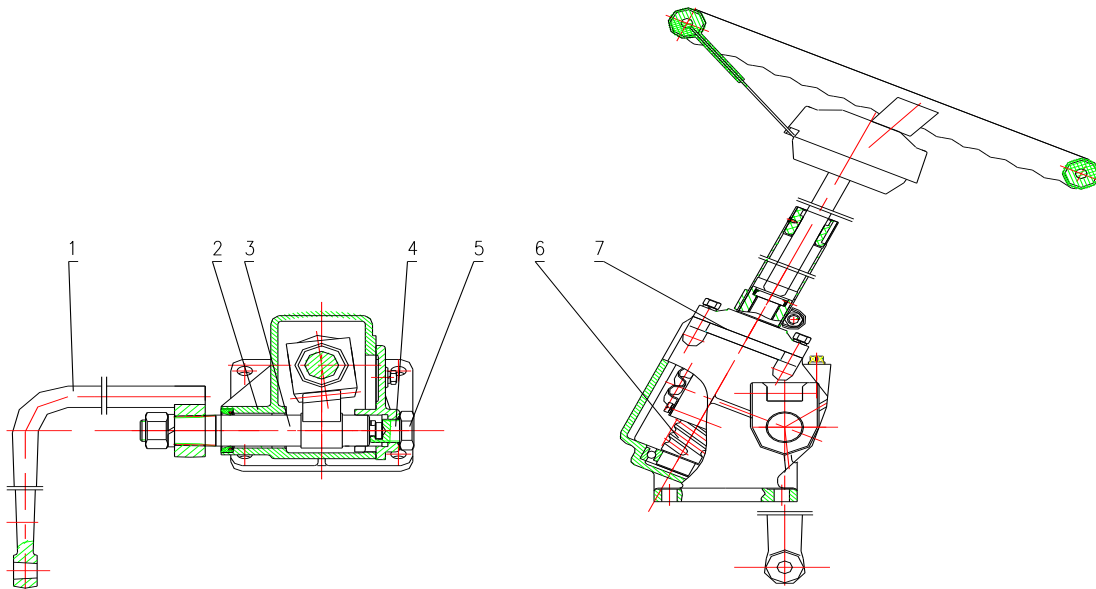

Figure 5-13 Structure of Recirculating Ball-rack and Sector Steering Gear

1.steering arm 2.steering gear housing 3.steering arm shaft 4.adjusting screw 5.adjusting nut
6.steering screw 7.adjusting gasket

● Adjustment:

➤ Adjustment of bearing clearance

In order to make the steering gear work normally, the conical bearing 32206 at the ends of the steering screw must be pretightened. When the clearance occurred due to worn bearing, you should eliminate the clearance by increasing/reducing the gasket. Its pretightening level shall be: without steering arm assembly, turn the screw shaft, and the force applied on the steering wheel shall be (3 to 5) N.

➤ Adjustment of engagement clearance of sector

During operation, the engagement clearance increases due to worn sector and rack, and thus making the idle travel of the steering wheel increase. You should adjust it when the idle travel exceed 20°.

When adjusting, unscrew the nuts of the steering gear housing on the right, turn the adjusting screw clockwise to reduce the engagement clearance. You should go on adjusting it till the steering arm is at the center position and turn the steering wheel to the left/right of 45°, and there is no engagement clearance between the rack and the sector. After adjustment, lock the nuts to avoid oil leakage.

5.3.7.3 Orbit hydrostatic steering gear with rotary valve(Figure 5-14)

Before the tractor is delivered, the steering system has been adjusted well. The following items shall be noticed during operation:

- Regularly check the threaded connection, tighten if loose. Oil leakage at each connection is not allowed

when the full hydraulic steering system is working.

- Frequently check the fluid level of the steering tank, fill as required.
- During operation, if you find the steering is too heavy or out of control, you should find the reason (reference to Chapter 2). Do not move the steering wheel reluctantly to avoid damage of the parts. It is strictly forbidden that 2 people turn the steering wheel simultaneously.

- When installing full hydraulic steering system, the steering gear shall be at the same shaft with the steering shaft, and there is clearance in the axial direction. After installation, check the steering wheel for agility.
- Make sure the oil is clean. Check air filter cartridge and oil frequently. Checking method: place 1 drop of oil onto the blotting paper. The oil shall be replaced if there is a black point in the center of the oil stain.
- After replacement of fresh engine oil, you should exhaust the air from the oil cylinder. Exhausting method: loosen the bolt connection of the steering oil cylinder, make the oil pump run at a low speed to exhaust the air till the oil passed through it without bubbles. Remove the connection between the piston rod of the steering oil cylinder, turn the steering wheel, and make the piston to the extreme left or right (it cannot be stayed at the extreme positions), then fill up the tank as required. Tighten all the threaded connections (do not tighten under the circumstance of pressure), link with piston rod. Check the steering system in each working condition for its normal work.
- Permanent overflow pump is a precision part. Generally speaking, it is not allowed to dismantle at random; when it needs to be dismantled, you should perform it on the clean spot and wash it by clean gasoline or kerosene.

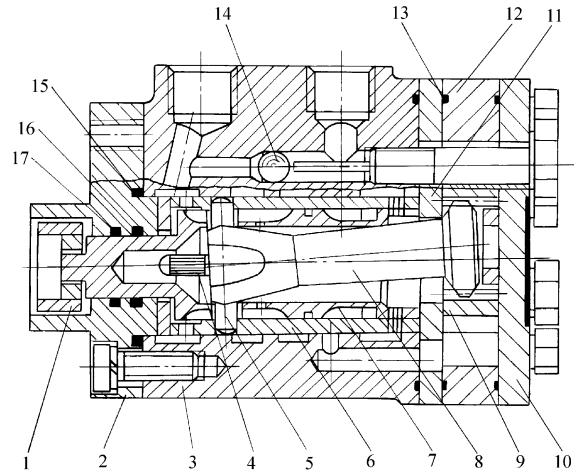

Figure 5-14 Structure of Hydrostatic Steering Gear

- 1.cross link block; 2.front cap; 3.valve body;
- 4.spring leaf ; 5.pull pin; 6.valve housing;
- 7.valve cartridge; 8.universal driving shaft;
- 9.rotor; 10.rear cap; 11.diaphragm plate;
- 12.stator; 13.“O”ring; 14.steel ball; 15.“O”ring;
- 16.“X”ring; 17.“O”ring;

Important notes: The safety overflow pressure for the overflow valve on the constant current overflow pump has been set before delivery; it should not be dismantled and adjusted without our approval.

5.3.9 Adjustment of hydraulic suspension system

5.3.9.1 Adjustment of adjusting spring (Figure 5-15)

Before force adjusting spring is put into the lifter housing, the following adjustment shall be done: relatively turn the upper link connect and spring rod to eliminate the clearance among each parts and components, and to ensure the clearance between spring pressure plate A and spring rod B is 2mm, then insert the pin. Put the force adjusting spring into the lifter housing, screw the nut, make the front end of the force adjusting spring assembly contact the lifter housing E, then insert the pin from the nut hole (Figure 5-15).

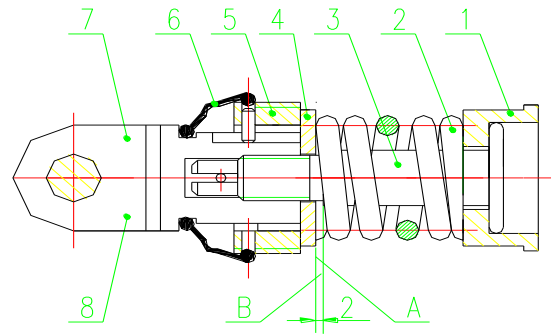

Figure 5-15 Adjustment of Adjusting Spring
1.spring seat 2.force adjusting spring 3.spring rod
4.spring pressure plate 5. nut 6.dust cover 7.upper link connect 8.pin

5.3.9.2 Force adjusting lever of lifter and adjustment of position adjusting cam (Figure 5-16)

Place the force and position adjusting handle on the upper contact edge of the sector plate (the position perpendicular to the bottom plane of the lifter housing body), make the internal lifting arm and the rear internal surface of the lifter housing with clearance of 4mm, at this moment, the angle between the external lifting arm and bottom plane of the lifter housing body shall be 60° , then adjust force adjusting lever and position adjusting cam respectively.

- Adjustment of the force adjusting lever

Adjust the force adjusting push rod to make the head of the force adjusting sleeve gasket contact with A, then adjust the length of the push rod to make the control end G of the force adjusting lever and the end face of the main control valve with a clearance of 1.5mm, (at this moment, the main control valve is on the extreme external position). After adjustment, lock with nut.

- Adjustment of position adjusting cam

Make the control end of the position adjusting lever contact with the extreme external position of the main control valve, turn the position adjusting cam and make it contact with the roller of the position adjusting lever assembly, then in the status of keeping contact of the roller of position adjusting lever and the cam, turn the position adjusting cam clockwise till the control end of position adjusting lever pushes

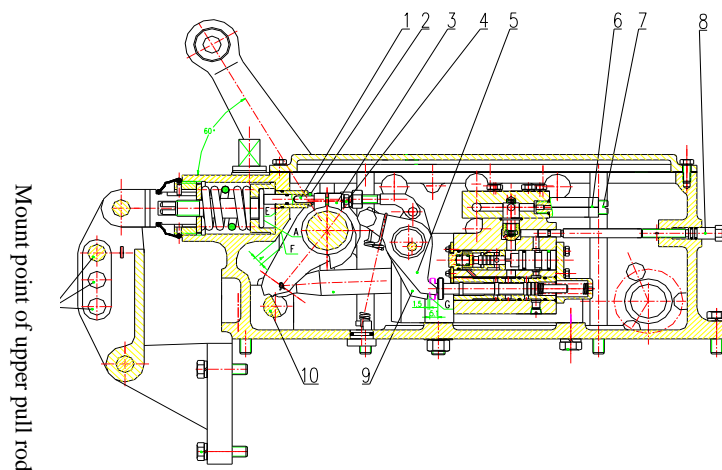

Figure 5-16 Adjustment of Force/Position Adjustment of the Lifter
1.force adjusting push rod 2. force adjusting sleeve gasket 3. positon adjusting cam 4.bolt 5. positon adjusting lever 6.locking nut
7.pressure adjusting thread stud 8.adjusting rod of intercepting valve and lowering valve 9.force adjusting lever 10.locking shaft assembly

the control valve to the neutral position (i.e. the main control valve moves inward 5mm from the extreme external position), at this moment, the distance between the control end of force adjusting lever and the end face of the main control valve is 6.5mm, then , fix the position adjusting cam on the lifting shaft by bolts.

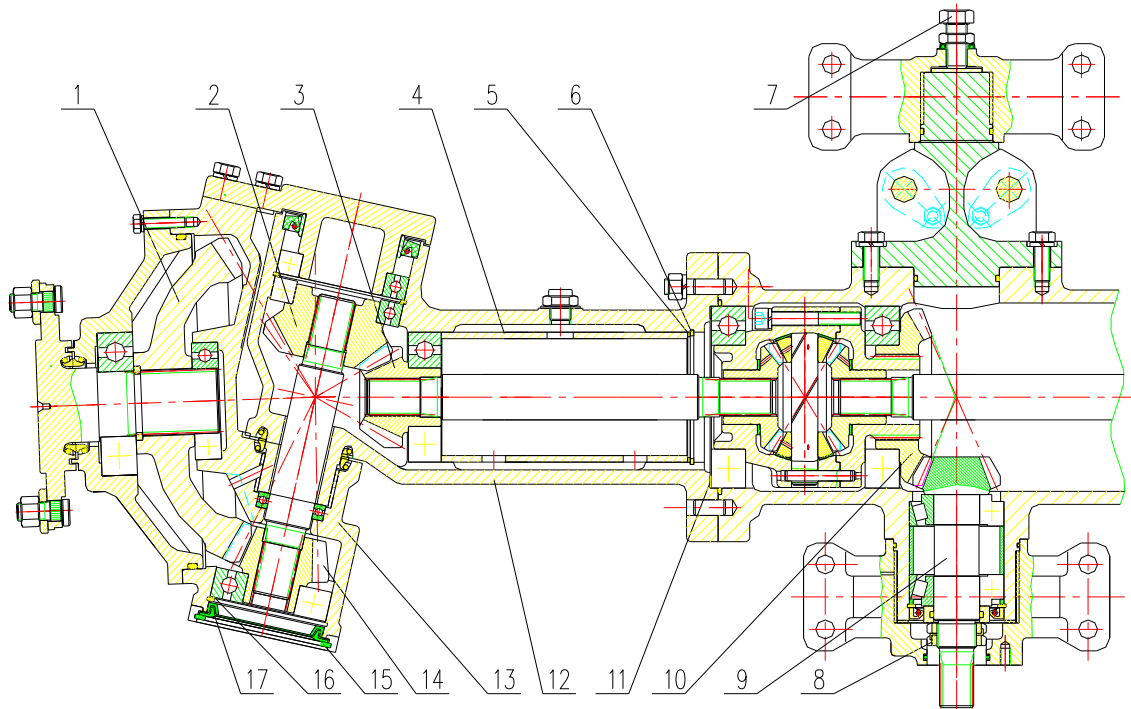

Figure 5-17 Structure of Front Drive Axle Assembly and Its Adjustment

1. gear wheel of final drive 2.driven gear 3. driving gear of half-axle 4. large spacer bush 5.adjusting pad 6.retainer ring 7.adjusting bolt M16 8.small round nut 9.driving gear of front central drive 10. driven gear of front central drive 11.adjusting gasket 12.half-axle sleeve 13.final drive housing 14.driving gear of final drive 15.sealing cover 16.adjusting pad 17.retainer ring

5.3.10 Structure of front drive axle and its adjustment

5.3.10.1 Adjustment of front toe-in

Adjusting method: the same as the related contents of the two-wheel drive front axle assembly.

5.3.10.2 Structure of front drive axle and its adjustment (Figure 5-17)

The power of front drive is transmitted into the front central drive via transfer case, and the power is distributed into the half-axle at two sides by the front central drive, then transmitted to the final drive and to make the driving gear turn.

When working in the farm field, especially work in the paddy field, the condition there is terrible and the mud/water is easily invaded onto the end face of the front/rear lining, that will cause end face wear and the axial float increase. You may adjust the bolt M16 in the front of the front supporting seat to keep normal axial float.

● Adjustment of the central drive

There are 2 bearings on the driving gears of the front central drive. After a period of operation, the axial float increases, thus, turn the small round nut to reduce the axial float of the bearing; when adjusting, load is not allowed; tighten the small round nut, then reverse (1/25 to 1/15) circle, lock the small nut. Turn the bevel gear shaft by hand, it shall be turned flexibly.

Gear backlash of conical gear and meshing mark of the front central drive will get a good meshing mark(contacting spot: along the direction of tooth length \geq 50%, along with the direction of the tooth height \geq 50%, and a little bit near the small end) and a proper clearance(0.2 to 0.4) mm by means of increasing/reducing adjusting gasket. Adjusting method: the same with the adjustment of contact meshing mark and backlash of the central conical gear of the “rear axle”. When the engagement clearance between the driving gear and driven gear of the front central drive increases, you may increase the adjusting gasket on the left of the differential to make this clearance return to normal.

Note: the large and small conical gear of the central drive are a matched pair. Do not install disorderly. When replacing, it is better to change together with the bearing; otherwise, that may influence its service life.

- Adjustment of final 2 pairs of conical gear

Small gear and bearing of the front final drive installed on the master pin and the conical gear and bearing of the half-axle will be worn due to long-time operation, which will cause the engagement clearance of the conical gear increased, thus, it is necessary to adjust. Adjusting method is as follows: unscrew the drain plug under the central drive housing, unclench the sealing cover on the left/right final drive housing, and let off the lubricant.

A. After the half-axle sleeve separates from the main reducer housing, adjust according to the engagement clearance (0.15 to 0.25) mm of the gear and contacting spot (along the direction of tooth height \geq 50%, along with the direction of the tooth length \geq 50%). To reduce the engagement clearance by increasing the gasket. After adjusting the engagement clearance and meshing mark, dismantle half-axle sleeve and retainer ring for hole in the connecting end of the main reducer housing, measure the distance between the spacer bush and the retainer ring slot, and this distance is the thickness of the adjusting gasket. Then put the adjusting gasket, install the retainer ring for hole.

B. Under the master pin, dismantle the retainer ring for hole and sealing cover, adjust according to the engagement clearance (0.15 to 0.25) mm of the gear and contacting spot (along the direction of tooth height \geq 50%, along with the direction of the tooth length \geq 50%). To reduce the engagement clearance by increasing the gasket. After adjusting the engagement clearance and meshing mark, measure the distance between the bearing 6308 and the retainer ring slot 90 for hole, and this distance is the thickness of the adjusting gasket. Then put the adjusting gasket, install the retainer ring 90 for hole, sealing cover and the retainer ring 102 for hole.

All the adjustments finish, set the front axle to the original state. Move the front wheel by hand, it shall be turned freely and without any abnormal sound. Then fill with the lubricant to the center of the oil pointer, screw the plug of the oil refiller.

6 Storage

When the tractor needs to be out of use for a longer time (more than one month) after the completion of farm work, it must be kept in proper storage and sealed up. The tractor should be kept on storage under sound condition, to prevent the machine from rust, aging and distortion.

Before the tractor's seal-up, it must undergo the thorough cleaning, adjustment and tightening of various joint parts, subject to the technical maintenance in compliance with the duty hours (refers to 4. Service and Maintenance) so that the tractor remains on good technical condition.

Importance:

1. During the long period out of use, it is very important to preserve and specially maintain the tractor. Otherwise, the worsened speed of tractor technique condition is quicker than its work time.
2. If there are no conditions available for the user to carry out the anti-rust treatment and the tractor needs to be out of use for several months or even longer, replaces at least the machine oil and oil filter and starts up once every month, the tractor and runs at low speed (20-23)min., checks every location to see whether there are anomalies. Keeps the tractor exterior dry and clean.

6.1 Causes of the damages occurred during storage of the tractor

The main causes of tractor damage during the deposit period are as follows:

- Rust: During the storage period, the air dust and moisture easily immerge into the machine by the slits, orifices etc. and causes the components to be polluted and rusted; As the pistons, valves, bearing and gears etc. stay for long time on a place, they will loose the flowing and pressured lubricant film protection, and produce the wears and rusty stains, cement blocks or clamping to the discard extent.
- Aging: Components made in rubber and plastic will get aged, deteriorated, brittle under the ultraviolet of sunlight, as a result of corrosion or rot.
- Distortion: Components such as drive belt and tires etc may produce the plastic distortion because of load for long time.
- Others: the electric appliance parts are affected with damp and the battery self-discharges etc..

6.2 Tractor's seal-up

- Prior to the seal-up, checks carefully the tractor, eliminates the failures and keeps it in sound technique condition. Clean up the exterior of tractor
- Evacuate the anti-freezing and frost-proof fluid from the radiator, cylinder block and water pump; the machine oil from the lubrication system and that from the hydraulic pressure system.
- Dismantles the battery, coats the lubricant on the polar and deposits it in a dark and ventilated room, where the temperature is not lower than 10°C.
- Evacuates the machine oil in the engine before it becomes cool, refuels the fresh oil, and keeps the engine run several minutes by reduced throttle, which will make the oil cling evenly on the surfaces of various moving parts.
- To add the lubricant into various lubrication points.
- Coats the contact surface of electric appliance, tie-in and non-painted metal parts with the dehydrated Vaseline [heat up to (100~200) °C (degree Celsius)].
- Loosens the engine fan belt, takes it down, if necessary, wraps securely and deposits it alone, sprays a coating of rust-proof agent into the pulley groove

The makeup painting should be made on the paint flakes on the exterior of tractor. ◦

- Evacuates the diesel oil from the tank and cleans up the diesel oil tank.
- Seals the open orifice of engine such as intakes/outlets with the protective material (e.g. canvas, waterproof cloth or oiled paper etc.) to prevent the foreign matter, dust and moisture from entry
- Places all control handles on the neutral gear position (including electrical system switch and stationary brake system), puts positively the tractor front wheel, and the suspension rod on the lowest position.
- Supports the tractor with the wooden stand, and unloads the tires Checks regularly the pressure in tires.
- The tractor should park in the hangar or the vehicle shed, where the environment should be dry and drafty. It is strictly prohibited to deposit it together with the corrosive goods and gas. If such conditions are not available and it is forced to park on open air, a dry terrace on higher land must be selected for parking with the rainproof cloth covering on the tractor.
- Parts dismantled from the tractor and attached tools should be cleaned up, well wrapped and preserved in the dry storehouse.

6.3 Maintenance during the tractor's storage

- During the storage period, the above mentioned requirements relevant to the tractor mothballs must be met.
- Monthly checks the tractor and parts to see whether there are abnormal phenomenon such as rust, corrosion, aging and distortion etc. Problems if any should be removed promptly.
- Revolves bi-monthly the crankshaft of engine (10-15r) to prevent from the interior rust. For the location necessary to add lubricant, the old lubricant should be removed for new replacement.
- It is necessary to start up, tri-monthly the tractor, and moves at low speed (20~30) min(minute), and check to see whether there are abnormal phenomenon on each part.
- Cleans up regularly the dust on the top of battery with dry cloth, and check up with the electrolyte liquid level and density of battery according to the “Battery Instruction for Use” ● The battery can discharge even when not in use. Recharges the battery one time per month.
- When transported by train and truck for long journey, the gears should not be engaged for the train and truck keep shaking on the way, which make the tractor tires moving forward and behind. Once the gears engaged, the moving of the tires will drive the parts such as gears, bearing, crankshaft and pistons etc rubbing without lubricant, which may cause the thermal ablation damage on the parts.

6.4 Tractor break-seal

- Removes the grease used for anti-rusting
- Reopens various sealed up nozzles Cleans up the tractor
- Adds the cooling liquid, machine oil, diesel fuel and lubricate every lubrication points according to the provisions.
- Checks the electrolyte liquid of battery according to the “Battery Instruction for application. Battery setting
- Removes the remainder anti-rust agent in the belt grooves of fan and installs the belt. Adjusts the transmission belt tension according to the specification (See: Engine Instruction for Use and Maintenance)
- Sets the battery , and coats the Vaseline on the terminals.
- Checks the tightening of the circuit and pipeline.
- Controls the tractor according to the requirements of Instruction

Note: As the tractors SINOVOL TB series may match with many types of engines, please refers to the “Engine Instruction for Use and Maintenance” for details of engine's seal up and brea-seal.

7 Delivery, acceptance and transportation

7.1 Delivery and acceptance

When purchasing the tractor, the user should carry out the acceptance testing on the purchased machine with the emphasis laid on several aspects as follows:

- 1 Whether the documents accompanying the machine are completely provided.

The attached documents include: "*Application Instruction of Tractor* ", "*Product Qualification Certificate*", "*3R (repair, replacement and refund) Warranty Voucher*", "*Attachments Packing List*" and "*Technique Documents attached to the Engine*" (supplied by the engine manufactory) and "*Catalogue of Tractor Spare-Parts*". Check to be sure whether the numbers of the "*Product Qualification Certificate*", "*Three-Packages-Serves Certificate*" and "*Technique Documents attached to the Engine*" comply with those of the delivery.

- 2 Whether the machine attachments are fully provided.

Carries out the verification on the machine attachments according to the "P/L of the Tractor Attachments ", which includes the spare-parts and attachment tools The "Technique Documents attached to the Engine" should be taken as valid for engine attachments (In case of questions, if any, please contact with the dealer).

- 3 Whether the machine is on sound state.

The operational conditions of machine may be probably changed after the consignment or shipment, When purchasing, the user may further verify the machine conditions.

7.2 Transportation

If the tractor is displaced by self-drive, the traffic regulations should be strictly observed with at least 60mts of distance maintained between two vehicles, to avoid the collision by accident; If the load transport selected, the following points should be satisfied with:

1. For the loading and unloading of the tractor, a smooth place should be selected.
2. By unloading the machine, a special unloading platform should be used.
3. An assistant should be available on the spot for guiding and the approach of persons not concerned are not allowed
4. After loading, the suspension rod will be put on the lowest position, the hand brake drawn on, the reverse gear engaged, startup key draws out, vehicle door locked up and the master switch out.
5. The front and rear four tires will be fixed with the iron wire on form of the number "8" , the tires ahead and behind reliably forelocked with wedges and rear axle hauled with iron wire.
6. Pull the rearview mirror inward as much as possible, and when necessary remove it. At the same time, ensure the hood and cab door and window are closed. For safety stand machine type, when necessary, the safety stand can be placed at folding position and should be secured firmly.
7. When the tunnels and the bridges are passed, the full attention must be paid to the load height, and the speed sufficiently slowed down while a turn is made.
8. While unloading, the hand brake should be first released, the drive gear should be shifted on and slowly driven down at lowest speed.



Attention:

1. While the tractor is loaded/unloaded, the truck-trailer should be fully braked to stop. The front/rear wheels safely forelocked so as to prevent the tractor and driver from the danger of overturn or fall-off by the

startup of the truck-trailer.

2. While loading and unloading, the tractor should be driven by the lowest speed, so as to prevent the tractor from the danger of overturn or fall-off of the tractor by the overspeed of the truck-trailer.

8 Main technical specifications of tractors

8.1 Type of product

Tractor products **SINOVOL** TB series have the meaning as follows:

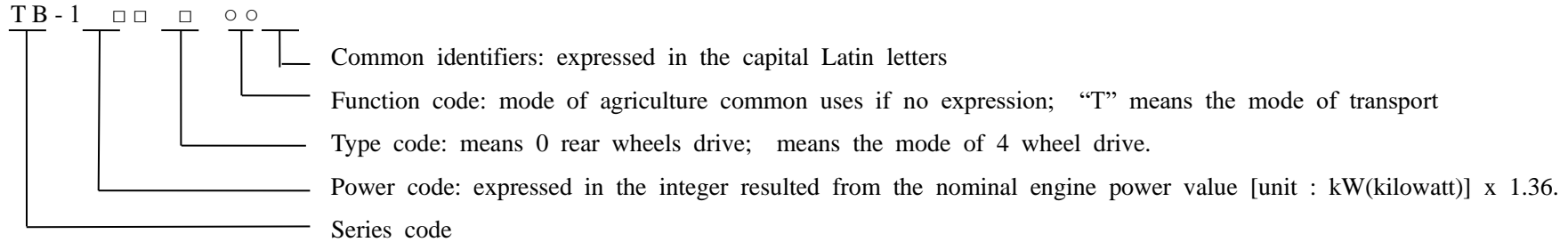

The contrast power values as follows:

Contrast power values to the product type

The nominal power of the wheeled tractors TB400C/TB400R/TB404C/TB404R: 32.4kW(kilowatt) (40hp)

The nominal power of the wheeled tractors TB500C/TB500R/TB504C/TB504R: 36.8kW(kilowatt) (50hp)

The nominal power of the wheeled tractors TB600C/TB600R/TB604C/TB604R: 44.1kW(kilowatt) (60hp)

The nominal power of the wheeled tractors TB700C/TB700R/TB704C/TB704R: 51.5kW(kilowatt) (70hp)

The nominal power of the wheeled tractors TB800C/TB800R/TB804C/TB804R: 58.8kW(kilowatt) (80hp)

Product implementing standard: Q/LWZ001 “Wheeled tractors SINOVOL”

8.2 Product Technical specifications

Table 8-1 Table of Product Technical specifications

Table 8-1 Table of Product Technical specifications

Model	TB 404	TB 504	TB 604	TB 704	TB 804
Power	40HP	50HP	60HP	70HP	80HP
Type	4x4 4WD	4x4 4WD	4x4 4WD	4x4 4WD	4x4 4WD
Engine Brand	Quanchai				
Engine Type	QC4105T40	QC4105T50	QC4105T60	QC4108T70	QC4108T80
Max. Torque (Nm @ engine rpm)	227~233/1700	227~233/1700	240~245/1700	265~275/1700	265~275/1700
(L) Fuel tank capacity	70L	70L	70L	70L	70L
KW/RPM Rating power of engine	29.4/2400	36.8/2400	44/2400	51.5/2400	58.8/2400
(g/kw.h) Fuel consumption @ nominal power	≤248	≤248	≤248	≤248	≤248
Air Intake Type	Naturally-Aspirated	Naturally-Aspirated	Naturally-Aspirated	Naturally-Aspirated	Naturally-Aspirated
(L) Displacement	4/4.087	4/4.087	4/4.087	4/4.324	4/4.324
Air filter type/size	Oil bath 7.8inch 255m3/h				
Torque reserve	27%	27%	25%	20%	20%
Clutch type/size	One-piece, dry, double-action/10 inches	One-piece, dry, double-action/10 inches	One-piece, dry, double-action/10 inches	One-piece, dry, double-action/11 inches	One-piece, dry, double-action/11 inches
No. of gears	12F+12R	12F+12R	12F+12R	12F+12R	12F+12R
Shift method	mechanical sliding sleeve	mechanical sliding sleeve	mechanical sliding sleeve	mechanical sliding sleeve	mechanical sliding sleeve

Max. speed	29.91	29.91	29.91	29.91	29.91
Gear position	side position	side position	side position	side position	side position
(L / MIN) Hydraulic output flow rate	38.4	38.4	38.4	38.4	38.4
Hydraulic output valve	two groups	two groups	two groups	two groups	two groups
Hydraulic filter types and capacity	wire mesh/63μm	wire mesh/63μm	wire mesh/63μm	wire mesh/63μm	wire mesh/63μm
Three-point-linkage	Cat.2	Cat.2	Cat.2	Cat.2	Cat.2
PTO Speed	540/760rpm	540/760rpm	540/760rpm	540/760rpm	540/760rpm
(610mm) kn Lifting Capacity	11KN/15KN 11KN/15KN (Enforced lift)	11KN/15KN 11KN/15KN (Enforced lift)	11KN/15KN 11KN/15KN (Enforced lift)	15KN 15KN (Enforced lift)	15KN 15KN (Enforced lift)
Tillage depth adjustment	Draft, position, position and draft mix control/position, float (Enforced lift)	Draft, position, position and draft mix control/position, float (Enforced lift)	Draft, position, position and draft mix control/position, float (Enforced lift)	Draft, position, position and draft mix control/position, float (Enforced lift)	Draft, position, position and draft mix control/position, float (Enforced lift)
mm The whole machine size (dimensions) mm	3970×1620×2650	3970×1620×2659	3970×1680×2720	4060×1828×2800	4060×1828×2800
(kg) Min. operation mass	With ROPS	2400	2520	2640	2800
	With Cabin	2580	2700	2810	2990
(mm) Wheel base	2041	2041	2041	2071	2071
Mini turning Radius (m)	4.3	4.3	4.3	4.5	4.5
Rated traction force(N)	14.5	14.5	15	16.5	16.5
Deck	Flat Deck	Flat Deck	Flat Deck	Flat Deck	Flat Deck

(mm) Minimum ground clearance	325	325	325	370	370
Heat ventilation cab	Optional	Optional	Optional	Optional	Optional
Front/rear wheel tread	1250/1300	1250/1300	1250/1300	1350/1450	1350/1450
tyre size	8.3-20/12.4-28	8.3-20/12.4-28	9.5-20/14.9-28	8.3-24/14.9-30 or wide Radial tyre	8.3-24/14.9-30 or wide radial tyre
Braking system	Wet type,disc brake	Wet type,disc brake	Wet type,disc brake	Wet type,disc brake	Wet type,disc brake
Steering type	hydraulic steering	hydraulic steering	hydraulic steering	hydraulic steering	hydraulic steering
Steering Angle (4 x4)	Front axle Max.Steering angle 50°	Front axle Max.Steering angle 50°	Front axle Max.Steering angle 50°	Front axle Max.Steering angle 50°	Front axle Max.Steering angle 50°
(options: all these types can Optional for ROPS ,Sunshade,swing drawbar, front/rear ballast, cabin)					

	Max. torque/rotate speed	N·m/r/min	≥152/1600±100	≥166/1600~1800	≥186/1600±100
	Nominal fuel consumption rate on the operating condition	g/kW·h	≤245		
	Nominal oil consumption rate on the operating condition	g/kW·h	≤1.5	≤1.5	≤1.5
	Lubrication mode	—	Compulsory and splash lubricating		
	Startup mode	—	Electric starting		
	Cooling	—	Compulsory water cooling		
	Air filter mode	—	dry or wet		
Transmission system	clutch	—	Dry single, double action		
	Gearbox	—	12+12 gear Synchronized shift		

	Rear axle	Central transmission	—	Spiral bevel gear pair					
		Differential	—	4 planet wheel, close					
		Differential lock	—	Pole coupling					
		Final transmission, rear	—	Planet gear					
	Front drive axle	Transmission shaft	—	Central transmission shaft					
		Central transmission, front	—	Bevel gear, close					
		Front differential	—	2 planet bevel gears					
		Final transmission, front	—	Spiral bevel gear					
running gears and undercarriages	Frame assembly		—	Frameless					
	Front suspension		—	Rigid suspension					
	Tire pressure	Front wheel	kPa	2WD:167~186(Farml Operation)/225~245(Fransportation Operation); 4WD:118~138(Farml Operation)/167~176(Fransportation Operation)					
		Rear wheel	kPa	118~138(Farml Operation)/167~176(Fransportation Operation)					
	tires Specification	Front wheel (Standard config)	—	8.3-20	8.3-20	6.0-16	8.3-20	6.0-16	8.3-20
		Rear wheel (Standard config)	—	12.4-28					
		Rear wheel(Optional config)		11-28(paddy field)					
Brake system	Service brake		—	Disc brake					
	Parking brake		—	Mechanical arm brake					
	Trailer brake control		—	Air pressure brake					
Steering system	Mode		—	Front wheel hydraulic steering					
	Steering gear		—	Cycloid rotary valvefull-Hydrostatic steering control units					
Working device	Mode of hydraulic system		—	Open centre semi-partition					

	hydraulic oil pump		—	Gear pump CB-F318L		
	Distributor		—	Slide valve type		
	Oil cylinder	Diameter x stroke	mm	90×110		95×120
		Type	—	Single-action		
	Size of suspension point		mm	Rear, three points suspension: Cat.I Upper suspension point: Joint hole× width: φ19.3×44 Bottom suspension point: Joint hole × width: φ22.4×35	Rear, three points suspension: Cat.II Upper suspension point: Joint hole x width: φ25.2×51 Bottom suspension point: Joint hole x width: φ28.7×45	
	Plough depth adjusting modes		—	Press adjustable, gear regulated, force position single control		
	Max.lifting power(610mm behind the suspension point)		K/N	>7.4	>8.3	>9.1
	Opening pressure of the system safety valve		M/Pa	17.5~18.0		
	Hydraulic pressure Output	Type	—	Simple Hydraulic Output or Multway Value		
		Amount	—	Simple Hydraulic Output 1 pair or 2 pairs		
Specification		—	M20×1.5			
Function		—	Supply the hydraulic power of hydraulic pump to the implement, to drive the implement.			
Power take-off shaft	Form		—	Rear Semi-detached		
	Specification		—	MI(φ35×6 teeth; or 38×8teeth) (GB1592-89)		
	Rotate speed		r/min	540/760		
	Max. gradient of driving shaft connecting with PTO		angle	15°		

Traction and towing devices	Traction device	Type		—	Swing rod (Option)
		Ground height		mm	344
		Max. vertical load	drawbar	Kg	0
	clevis		Kg	600	
Towing device				—	Clevis (Option)
Cab				—	Option, simple cab or section shock-absorbing cab, with fan or warm air blower or air conditioning.
Safety stand				—	Option, double column(non-cab)
Pilot seat				—	Mechanical floating, PVC coating, height, forward/rearward adjustable
Electric appliance instrument system	Electric appliance system			—	12 volts, negative earth, twin-wire
	Generator	Type		—	Read engine specification
		Voltage		V	14
		Power		kW	0.75
	Regulator	Type		—	(Built-in regulator)
		Regulated voltage		V	14
	Startermotor	Type		—	Read engine specification
		Voltage		V	12
		Power		kW	3.7
	Battery	Type		—	6-QW-100
		Voltage		V	12
		Capacity		A·h	100
		Amount		—	1
	Lighting and signal device	Head lamp		—	12V, 55W, 2 Nos. (2 Nos. at left and right side respectively)
Front direction indicator		—	12V, 21W, 2 Nos.		

		Front position lamp	—	12V, 55W, 2 Nos.
		Rear combined lamps	—	Width LED lamp, 2 Nos./Steering lamp 21W, 2 Nos./braking LED lamp, 2 Nos./reflector (red) at left and right
		Rear working lamp	—	12V, 55W, 2 Nos. (safety stand)/12, 55W, 4 Nos. (cab)
		Trailer plug	—	Seven-hole socket with 1 plug
	Watch and warning device	Combination instrument	—	With tachometer, water temperature gauge, oil level gauge, hour meter, 1 Nos.
Warning device		—	1. Charging indication lamp, left and right steering indication lamp, position indication lamp, driving beam indication lamp; 2. Air brake failure warning lamp (air brake machine type optional), low oil pressure warning lamp, engine starting indication lamp, engine failure indication lamp; 3. Reflector; 4. Safety warning mark.	
Perfusion Volume capacity	Radiator		L	12
	Fuel tank		L	65
	Engine oil pan		L	Read engine specification
	Oil bath air cleaner		L	Fill oil to the regulated level
	Oil, Hydraulic pressure steering		L	0.8
	Oil, Brake		L	/
	Oil, Transmission system		L	2WD:20,4WD:27
	Front drive axle		L	4WD:7

8.3 Theory speed of tractor

SINOVOL-TB Series 40-80hp tractors theory speed

Model	TB404/504/604/704/804			
	12F+12R		8F+8R	
	Drive gears	Reverse gear	Drive gears	Reverse gear
Low I	2.37	2.07	2.37	2.07
Low II	3.57	3.13	3.57	3.13
Low III	4.51	3.95	4.51	3.95
Low IV	7.55	6.62	7.55	6.62
Medium I	5.96	5.23	/	/
Medium II	9.00	7.89	/	/
Medium III	11.36	9.96	/	/
Medium IV	19.02	16.68	/	/
High I	12.05	10.56	12.05	10.56
High II	18.20	15.95	18.20	15.95
High III	22.98	20.14	22.98	20.14
High IV	38.46	33.71	38.46	33.71

Note:

- 1.The values in above table are the theoretic speed when engine speed is 2400 RPM and with standard rear tire 12.4-28;
- 2.If be with other option rear tires,based on the above-mentioned table the real values need multiplied by corresponding coefficient "a" ;
Option rear tire,paddy tire 11-28, "a" =1.04;
Option rear tire,standard 13.6-28, "a" =1.04;
Option rear tire,standard 14.9-28, "a" =1.083.
- 3.Every parameter in the technology specification table are the ones under the test of standard configure.

9 Disassembly and disposal

After the machine reaches its due service life, and for yours personal safety and the protection of social environment, please deliver it to the licensed company specialized in the disassembly and recycle operation.

When do it, please disassemble in sequence of from top to bottom, then outside to inside. In case of large object or heavy mass, the special hoisting mechanism must be used. Please handle the battery to the special battery recycling company. Please collect the waste oil and so on for proper treatment. Do not reject them randomly, or they may cause the pollution risk to the environment.



Warning: The battery electrolyte is corrosive, do not let it splash into on your eyes, skin and clothes. If such happens, you must use the clear water to clean it immediately, and go to the hospital for treatment as soon as possible, in order to avoid the accidental injury.



Attention: the replaced the battery acid liquor can cause the pollution to the environment, do not splash it at random, in order to avoid the accidental damage.

The replaced machine oil is reject oil material, it cannot be discarded at will, in order to avoid the accidental damage.

We kindly remind you, when or after knocking down, the improper placement will cause the personal injury on lack of special tools and practical experience.



Warning: When disassembling the large or heavy mass object, the special hoisting mechanism must be used, and be careful of your personal safety!

10 Warranty terms

10.1 Product warranty basis

The warranty service for the wheeled tractors SINOVOL TB series: TB404/TB504/TB604/TB704/TB804 will be undertaken according to the following documents and regulations.

“Rules of Obligation for Repair, Replacement and Reimbursement of the Agro-Machinery Products”.

International Eco./Com. Qty1998, No.123

“Law of the Product Quality of the PRC”.

“Law of the Consumer Rights and Interests Safeguard of the PRC”.

10.2 Cases not covered by the warranty policies

According to the relevant laws and regulations, some cases are not covered by our warranty policies. The details are referred to the relevant chapters in the “3R (repair, replacement and refund) Warranty Voucher”.

Note: Some behaviors will possibly invalidate the warranty condition. The details are referred to the relevant chapters in the “3R (repair, replacement and refund) Warranty Voucher”.

Note: If the user rebuilds voluntarily the tractor or uses it for purposes other than stipulated in the instruction for use, it will not be covered by the warranty scope of manufacturer, to which we kindly ask you to pay attention.

Note:

1. When user accepts warranty, he should present warranty certificate which should be kept well.
2. When the machine has failure and when require warranty, dealer should be informed of following content: machine model, factory No., engine model and type, and nameplate, service time, and failure detail;
3. Warranty service parts supply time description: parts will be supplied within 5 years after the product production stops; warranty parts but within warranty period; special parts delivery time would be determined after discussion; for warranty parts, when the supply period is exceeded, the supplied parts price and delivery time would be determined after discussion;
4. Please always use specified parts and oil for product.

11 Appendixes

11.1 Oils and Solutions Used on the Tractor (Table 11-1)

Table 11-1 Oils and Solutions Used on the Tractor

Application locations of oils and solutions	Oils and solutions						
Fuel tank	Domestic standard	GB/T 252 compliant light diesel oil	Above 20°C	(4~20)°C	(-5~4)°C	(-14~-5)°C	(-29 ~ -35)°C
			No.10	No.0	No.-10	No.-20	No.-35
	International standard	Adopt ASTM D-975 fuel oil. Under general air temperatures, use 2-D grade oil; when ambient temperatures are below 5°C, use 1-D grade oil. Fill the engine fuel and oil strictly following the instructions given in the accompanying documents.					
Engine sump	Domestic standard	<p>Diesel engine sump, injection pump, and governor use CF-4 grade equivalent diesel engine oils (GB11122). Do not replace with common diesel engine oil. Fill the engine fuel and oil strictly following the instructions given in the accompanying documents.</p> <p>When ambient temperatures are above or within the range of -10°C~+50°C, use 20W-50 CF-4 diesel engine oil.</p> <p>When ambient temperatures are within the range of (-20~+50)°C, use 15W~40 CD diesel engine oil.</p> <p>When ambient temperatures are within the range of -25°C~+40°C, use 10W-40 CF-4 diesel engine oil.</p> <p>When ambient temperatures are within the range of -30°C~+40°C, use 5W-40 CF-4 diesel engine oil.</p>					
	International standard	Engine sump, injection pump, governor and oil bath air cleaner use the oils with their viscosity grades compliant with SAE viscosity classification. Below -5°C, use SAE 10W oil; above -5°C, use all-season SAE 15W/40 multi-grade oil. Quality class should comply with API CD grade standard.					
Water radiator	<p>When ambient temperatures are above 4°C: The tractor cooling system uses clean soft water.</p> <p>When ambient temperatures are below 4°C: The tractor cooling system must use antifreeze.</p> <p>When the minimum ambient temperature is above -15°C: Use -25# long-acting antifreeze (SH/T0521).</p> <p>When the minimum ambient temperature is above -25°C: Use -35# long-acting antifreeze (SH/T0521).</p> <p>When the minimum ambient temperature is above -35°C: Use -45# antifreeze (SH/T0521).</p>						
Gearbox-rear axle, hydraulic lifter, and front drive axle	Domestic standard	N100D dual purpose transmission/hydraulic oil. Implementing standard: Q/LWZ B119.					
	International standard	can use MF1135 (Massey Ferguson), M2C 86A (Ford), or J20A (John Deer) general-purpose oil.					
Steering oil tank	Domestic standard	L~HM32 wear-resistant hydraulic oil.					
Oil cup	Domestic standard	GB/T 7324 compliant general purpose lithium base grease for automobile.					
	International standard	Use NLGI D-217 grease with a viscosity grade of 2.					

Important issues:

1. Dual -purpose hydraulic/transmission oil, diesel oil and diesel engine oil must be settled for at least 48h before added for use.
2. Hybrid use of oils of different brands and manufacturers is strictly forbidden so as to avoid affecting service performance of the machine.
3. On the tractors with heater unit equipped, antifreeze must be used in winter to avoid frost cracks on it.
4. Fill the engine fuel and oil strictly following the instructions given in the accompanying documents of engine, so as not to adversely affect the performance of the machine.

11.2 Tightening Torque Table of Major Bolts and Nuts (Table 11-2)

Table 11-2 Tightening Torque Table of Major Bolts and Nuts

Connecting location	Connection	specification	Tightening torque (N·m)
Drive train	Bolt connecting engine with gearbox	M12	77.7
	Bolt connecting gearbox with rear axle	M12	77.7
	Fixing bolt of the bearing of differential	M12	77.7
	Fixing bolt of the large bevel gear	M10	44.5
	Bolt joining the housing of drive shaft and that of rear axle	M12	77.7
Steering and running systems	Bolt joining the hub and web of driving wheel	M14	123.6
	Bolt joining the front driving wheel and the hub and web	M14	123.6
	Bolt joining the front driving wheel and the hub and web	M12	77.7
	Bolt at the steering ball joint	M12	77.7
Front axle assembly	Bolt connecting the diesel engine to the frame	M16	192.9
Hydraulic suspension system	Bolt joining the housing of lifter and that of rear axle	M12	109.3
	Bolt joining the oil cylinder end and the housing of lifter	M14	173.9
	Bolt joining the brace of upper drag link and the housing of rear axle	M12	77.7
Front drive axle	Bolt joining the driven gear of front differential assembly and the differential	M10	44.5
	Bolt joining the housing of left semiaxle and that of right semiaxle	M10	44.5
	Bolt joining the housing of Tee joint and the upper cover	M8	31.6
	Bolt joining the housing of final drive and the lower cover	M10	62.6
	Bolt joining the housing of final driver and the cover	M10	44.5
	Bolting joining the steering arm-busher subassembly and the housing of final drive	M12	77.7
	Bolting connecting the diesel engine to the bracket	M16	192.9
	Bolt connecting the swing base assembly to the bracket	M12	77.7

Note: A tolerance of $\pm 10\%$ is permitted for the torques in the table.



Warning: When tightening the major bolts and nuts on the tractor, torque wrenches must be used to avoid such hazards as complete machine performance reduction and personal injury caused by failure to meet the requirements for the tightening torques.

11.3 Reinforced, seal and O-ring seal (Table 11-3)

Table 11-3 Specifications of the reinforced seal O-ring seal

SN	Standard code	Name and model	Installation position	Quantity
1	GB/T 9877.1	Oil seal FB50×72×8D	Rear end of the power output rear axle	2
		Oil seal FB40×62×8D	Where the steering knuckle meets the hub	2
		Oil seal FB30×40×7D	Seal of the transfer case	1
		Oil seal FB40×62×8D	Outer end at inside of long half shaft of rear axle (up to 52 horsepower)	2
		Oil seal FB40×62×8D	Intermediate section of Shaft I in the gear box	1
		Oil seal FB40×62×8D	Outer end at inside of long half shaft of rear axle (55-60 horsepower)	2
		Oil seal B65×90×12D	Driven bevel gear of second-stage reduction of front drive	2
		Oil seal FB50×72×8D	Rear end of the driving bevel gear base of front drive	1
2	GB/T3452.1	O-rings 23.6×1.8G	Rear end of the auxiliary clutch shaft in the gear box	2
		O-rings 15×2.65G	Differential lock operating shaft	1
			Where the pressure oil pipe meets the gear pump	1
		O-rings 11.2×2.65G	Power output control rod	1
		O-rings 115×3.55G	Outer end at inside of long half shaft of rear axle	2
		O-rings 61.5×5.3G	Driving bevel gear of second-stage reduction of front drive	2
		O-rings 19×2.65G	Where the oil-suction pipe meets the gear pump	1
			Where the pressure oil pipe meets the lifter	1
		O-rings 17×2.65G	Where the connecting plate of inlet oil pipe meets the housing of lifter	1
		O-rings 20×2.65G	Locking shaft of lifter	3
			Seal for the crank of brake	2
		O-rings 132×3.55G	Location for sealing the transfer case and the rear-axle housing	1
		O-rings 25×2.65G	Seal of the fork shaft of transfer case	2
		O-rings 43.7×2.65G	Between the drive shaft and sleeve of the transfer case	4
		O-rings 18×2.65G	Seal for the crank of brake	2
		O-rings 140×3.55G	Driven bevel gear of first-stage reduction of front drive	2
O-rings 34.5×3.55G	Driving bevel gear of first-stage reduction of front drive	2		
O-rings 236×5.3G	Driven bevel gear of final-stage reduction of front drive	2		

SN	Standard code	Name and model	Installation position	Quantity
		O-rings 58×3.55G	Where the front bracket of front drive meets the housing	1
		O-rings 47.5×3.55G	Where the front supporting shaft of front drive meets the base	1
		O-rings 90×2.65G	Where the rear base meets the housing	1
		O-rings 45×3.55G	Rear end of the rear base of front drive	1
		O-rings 17×2.65G	Oil inlet of the distributor	1
		O-rings 15×1.8G	Oil inlet of the distributor	1
		O-rings 50×5.3G	Cut-off valve and lowering valve adjusting rod	1
		O-rings 11.2×2.65G	Where the lowering-speed adjusting bar meets the housing	1

Note: This table does not include nonstandard oil seals and O-rings.

11.4 Rolling bearings (Table 11-4)

Table 11-4 Rolling bearings

SN	Standard code	Name and model	Installation position	Quantity	Note
1	GB/T 276	Bearing 6208	Intermediate section of Shaft I in the gear box	1	
		Bearing 6305	Rear end of Shaft I in the gear box (single-action clutch)	1	
		bearing 6107(6007)	Rear end of Shaft I in the gear box (double-action clutch)	1	
		Bearing 6210	Front end of the auxiliary driving shaft in the gear box	1	
		Bearing 6,308N	Rear end of the auxiliary driving shaft in the gear box	1	
		Bearing 6,306N	Front end of Shaft II in the gear box	1	
		Bearing 6208	Rear end of Shaft II in the gear box	1	
		Bearing 6307	Rear end of the auxiliary driven shaft in the gear box	1	
		Bearing 6305	Intermdeidate section of the power output rear axle	1	
		Bearing 6,404N	Rear end of rear axle PTO shaft	1	
		Bearing 6306	Rear end of rear axle PTO shaft	1	
			Inside the transfer case	1	
		Bearing 6308	Rear end of rear axle PTO shaft	1	
		Bearing 6212	Outer end at inside of long half shaft of rear axle (up to 52 horsepower)	2	
Bearing 6214	Outer end at inside of long half shaft of rear axle (55-60 horsepower)	2			
Bearing 6211	Inner end at inside of long half shaft of rear axle	2			

SN	Standard code	Name and model	Installation position	Quantity	Note
		Bearing 6211N	Rear end of gearbox output shaft	1	
		Bearing 6309	Rear end of the power output rear axle	1	
		Bearing 6209	Driving bevel gear of first-stage reduction of front drive	2	
		Bearing 6310	Outer flank of the driven bevel gear of second-stage reduction of front drive	2	
		Bearing 6203-Z	Inside the flywheel of engine	1	30、35use
		Bearing 6204-Z	Inside the flywheel of engine	1	40use
2	GB/T 283	bearing NUP2210	Rear end of the rear center small driving bevel gear	1	
		bearing N208	Inner flank of the driven bevel gear of second-stage reduction of front drive	2	
3	GB/T309	Bearing 51108	Where the steering knuckle mates with the sleeve	2	
4	GB/T 297	Bearing 32208	Rear axle driving spiral bevel gear	2	
		Bearing 2007113	Rear axle differential	1	
		Bearing 30211	Rear axle differential	1	
		Bearing 30208	Driven bevel gear of first-stage reduction of front drive	2	
		Bearing 30210	Driving bevel gear of second-stage reduction of front drive	2	
		Bearing 30210	Driving bevel gear of second-stage reduction of front drive	2	
		Bearing 7211	Front middle differential	2	
		Bearing 2007107	Rear end of the middle front driving bevel gear	1	
		Bearing 7208	Front end of the middle front driving bevel gear	1	
		Bearing 32206	Where the steering knuckle mates with the hub	2	
			Where the steering rocker mates with the housing	2	
			Where the steering knuckle mates with the hub	2	
		Bearing 32208	Where the steering knuckle mates with the hub	2	
			Where the steering knuckle mates with the hub	2	
Bearing 6205	Where the steering column mates with the housing	1			

SN	Standard code	Name and model	Installation position	Quantity	Note
5	Release bearing of the clutch	986911	Clutch thrust bearing seat	1	Single-action
		996713	Clutch thrust bearing seat	1	Double-action
6	Non-standard	977907	Where the steering column mates with the housing	1	
	Non-standard	776701	Where the steering column mates with the housing	1	
7	GB/T 308	Steel ball 8.0000G100b	Gearbox shift shaft	4	
		Steel ball 9.5V	Shfit shaft for the power output rear axle	1	
		Steel ball 8.7312G400b	Steering arm of front drive	2	
			Locking shaft of the lifter	1	
Steel ball 18.0000G100b	Braking disc and differential bearing block	12			
8	GB/T 309	Needle $\phi 5 \times 25.8$	Planetary gear shaft of final drive (up to 52 horsepower)	264	
		Rolling $\phi 6 \times 23.8$	Planetary gear shaft of final drive (55-60 horsepower)	264	
9	JB/T 7918-1997	bearing K20 \times 26 \times 20	Beteen the auxiliary shift driven shaft and Shaft II.	1	

11.5 Supporting farm machines and implements (Table 11-5)

Table 11-5 Supporting farm machines and implements

Category	Tractor model	Supporting implement	Implement model	Main technical parameters	Supporting enterprise
Tilling machinery	TB404	Mounted 5-furrow plough	1L-427	Tilling depth (16~20) cm	Baoding Shuangying Agricultural Machinery Co., Ltd. Baofeng Agricultural Machinery Co. Ltd. Dezhou Shandong, Baichuan Plough Plant, Weishi County, Henan Province Heishan county Machinery Co., Ltd. Liaoning province Qishan Agricultural Machinery Co., Ltd. Shanxi province Jishan Agricultural Machinery Co., Ltd. Shanxi province Nanning Yongjiang Machinery Co., Ltd. Heilongjiang Nenjiang
		Mounted 3-furrow plough	1L-427	Tilling depth (18~22) cm	
		Mounted 3-furrow plough	1L-427	Tilling depth (14~18) cm	
		Mounted 4-furrow plough	1L-425	Tilling depth (18~22) cm	
	TB504	Mounted 4-furrow plough	1L-425	Tilling depth (18~22) cm	
			1L-427	Tilling depth (14~18) cm	

Category	Tractor model	Supporting implement	Implement model	Main technical parameters	Supporting enterprise
		Mounted 5-furrow plough	1L-427	Tilling depth (16~20) cm	Agricultural Machinery Factory Qianjin plough factory Shangqiu Henan province
	TB404	Rotary tiller	1GQN-160	Tilling depth (12~15) cm, tilling width160cm	Nanchang Rotary Tiller Factory Lianyungang Rotary Tiller Factory Xi'an Rotary Sower Factory Haofeng Machinery Manufacturing Company.
	TB504		1GQN-170	Tilling depth (12~15) cm, tilling width170cm	
sprayer	All series	Suspended light harrow	3W-300/8	Pesticide tank capacity: 300L Plowing width: 800cm	Chengong yizhong zhibao Machinery Factory Handan city Heilongjiang Nenjiang Agricultural Machinery Factory
Soil preparation machinery	TB404	24 Suspended light harrow	1BQX-2.0	Tilling depth (8~12) cm, Plowing width200cm	Jiamusi North Machine Building Co., Ltd. Xuzhou Huaxing Agricultural Machinery Co., Ltd. Heilongjiang Nenjiang Agricultural Machinery Factory Zhumadian Agricultural Machinery Factory Ningjinjixin Agricultural Machinery Factory Hebei province Harbin Hongwei Technology Development Co., Ltd. Nanning Yongjiang Machinery Co., Ltd. Woer Technology Co., Ltd.
	TB504	34 light harrow	IBY-3.4	Tilling depth (8~12) cm, Plowing width 340cm	
		24medium-harrow	2BJ-2.2		
Seeding machinery	TB404/ TB504	Seeder	2BJ-4 (soy bean) 2BSW-2.4 (wheat)	Seeding 4 rows , row spacing (50~70) cm Seeding width240cm	Heilongjiang Baihua Industries Group Baihua Plowing Machinery Factory Dongxingyongji Agricultural Machinery Co., Ltd.

Category	Tractor model	Supporting implement	Implement model	Main technical parameters	Supporting enterprise
			2BJ-4W (soy bean)	Seeding 4 rows , row spacing (50~70) cm	Heilongjiang province Heilongjiang Nenjiang Agricultural Machinery Factory Bonong machinery Manufacturing Co., Ltd. Heilongjiang province. Yongfa Agricultural machinery Factory Luannan county. Wafangdian Precision Seeding Machine Building Co., Ltd. Shijiazhuang Agricultural Machinery Co., Ltd. Xinjiang Agriculture machinery Akesuli Agricultural Machinery Co., Ltd.
	TB404/TB504	Rotary seeder	SGTNB-15 0Z3/6	Suitable for soil of medium or lower class, suitable for Tilling depth (10~15) cm	Xi'an Rotary Sower Factory Dingzhou Kaiyuan Machinery Manufacturing Co., Ltd., Hebei Province
Paddy-field plowing implements	TB404	Paddy-field slurry-preparation machine	1ZSN-240	Tilling depth(8~10)cm	Hongxinglong Machinery company Lianyungang Rotary Tiller Factory
	TB504		1ZSN-260		
Straw returning	TB404	Straw returning machine	4JH-1.2	Straight blade, Working width 120cm	Dingzhou Kaiyuan Machinery Manufacturing Co., Ltd., Hebei Province Shijiazhuang Agricultural Machinery Co., Ltd. Dezhou Huabei Farming Equipment Co., Ltd., Shandong Province Haofeng Machinery Manufacturing Co., Ltd.,
			4JHY-1.2	Working width 120cm, Stubble left (2~ 8)cm	
			4J-110	Working width 110cm, Stubble left (2~ 8)cm,	
	TB504	Straw-returning machine	4JH-1.5	Working width 150cm, Stubble left (2~ 8)cm,	

Category	Tractor model	Supporting implement	Implement model	Main technical parameters	Supporting enterprise
Compound implements	TB404/554	Stubble cleaning, rotary tilling, ridging and suppressing	SGTN-140	Working width 140cm, form two ridges, Tilling depth(12~15)cm	Shenyang Huayuan Machine Building Co., Ltd. Lianyungang Rotary Tiller Factory Nanchang Rotary Tiller Factory
harvesting machine	TB404	Wheat carrier	1L-427	cutting width:170cm	Zibo Juming Machinery Co., Ltd., Shandong Dafeng Machinery Co., Ltd., Guilin harvesters factory
	TB504	Wheat carrier	1L-427	cutting width: 200cm	
trailer	TB404	Agricultural trailer	1L-427	Load :3 000kg	Ningjin trailer main workshop Beijing trailer factory Qingdao yakai Machinery factory Weishibaichuan Machinery factory Henan province
	TB504		1L-427	Load 5 000kg	

Important issues:

1. Before shopping farm machines and implements, select types of the matching ones roughly, consult dealers , according to the operational conditions (soil resistance, agricultural requirements, etc.) of the areas where you will work on and referring to this list.
2. Determine the main technical parameters of the farm machines and implements such as models according to the operational conditions (soil resistance, agricultural requirements, etc.) of the areas where you will work on and referring to the advisory advices so as to realize rational matching. Improper matching will bring adverse effect to the machine set.
3. Work efficiency and effect of the same implement vary with operational conditions (soil resistance, agricultural requirements, etc.). Therefore, you should determine working speed and width, etc. properly according to local operational conditions.



Notice: Before using a supporting farm implement, the operator should read its “operation and maintenance manual” carefully and familiarize its construction, performance, method of operation for rational matching so as to avoid machine damage and personal injury caused by accident.

Dear customers

Thank you for your shopping, choosing and using SINOVOL TB series wheeled tractors. We are willing to provide you with best service by serving you wholeheartedly, solving the problems that you encounter during use promptly and effectively, and meeting your demands to the maximum extent.

Now, we will send the “Customer Information Feedback Form” along with the manual to you. Please complete it in round hand and then mail it to Three Guarantees Service Department of Weifang Yinquan Machinery Co., Ltd. at the following address by registered letter: NO.222,siping road, Weifang, Shandong, the People's Republic of China. We will input your “Customer Information Feedback Form” into computer for storage in order to provide you with “Three Guarantees” service.

We really appreciate your cooperation and great support!

Customer Information Feedback Form

Product model		Tractor identification number			Engine Manufacturer	
Engine number		Delivery date			Purchase date	
User name		Age		Education level		Working years as driver
Home address				Telephone number		Zip code
Main purposes of your purchase				Tractor load		
Occurrence time and causes of troubles						
Names and conditions of damaged parts						
Improvement ideas and suggestions						

Note: This feedback form shall be completed truthfully by the owner (or operator) so that we can know service condition of your tractor for provision of better customer service. Filling in a copy of this customer information feedback form is valid.



Professional supplier of Tractor and Implements

WEIFANG SINOVOL MACHINERY CO.,LTD

ADD:NO.222,SIPING ROAD,WEIFANG,261000,CHINA

[TEL:0086-18553692856](tel:0086-18553692856)

[HTTP:WWW.SINOVOL.COM](http://WWW.SINOVOL.COM)