

Contents

1. Attaching to a tractor

1 Name of Darts and its function

2 Applicable tractor size

3 Assembling

- 1). Packing opening
- 2). Details of attached parts
- 3). Process of assembling

4 Attaching to a tractor

- 1). Preparation for attachment
- 2). Attachment 10 a standard 3P

3). Attachment of power package operation rope

4). Attachment of buzzer

5). Method of twine threading

5 Attachment of Universal joint

- 1). Universal joint length check
- 2). Method of cutting
- 3). Method of outer safety covers removal
- 4). Connection of universal joint

2. Inspection before operation

1 Inspection before operation

- 1). Inspection of tractor parts
- 2). Inspection of connecting parts
 - (1)Inspection of 3P connecting parts
 - (2)Inspection of universal joint

3). Inspection of the machine

2 Inspection of tractor engine running

- 1). Inspection of tractor hydraulic
- 2). Inspection of the machine hydraulic system

3 Lubrication spots table

3. Operation method

1 Purpose of this machine

2 Adjustment for operation

- 1). Adjustment of pick-up height from ground
- 2). Adjustment of twine binding number
- 3). Adjustment of cover shield and side cover
- 4). Adjustment of bale density

3 Operation methods in field

- 1). Method of windrow making
- 2). Field operation

4 Transportation

4. Out Of season storage

1. Maintenance after operation

2. Detaching from a tractor

3. Storage our of season

5. Inspection and Maintenance

1 Inspection and maintenance table

2 Adjustment for each part

- 1).Roller chain tension adjustment
 - (1)Adjustment of tension spring
 - (2)Adjustment of tension plate
 - (3)Adjustment of power package
- 2).Adjustment of drive part for pick up

3).Adjustment of twine tension

4).Adjustment of arm tension spring

5).Adjustment of binding knife

6).Adjustment of bale density detection Ink

7).Adjustment of pick up suspension

8).Adjustment for closing speed of gate

6. Trouble shooting

1. Trouble shooting table

1 Attaching to a tractor

1 Name of parts and its function

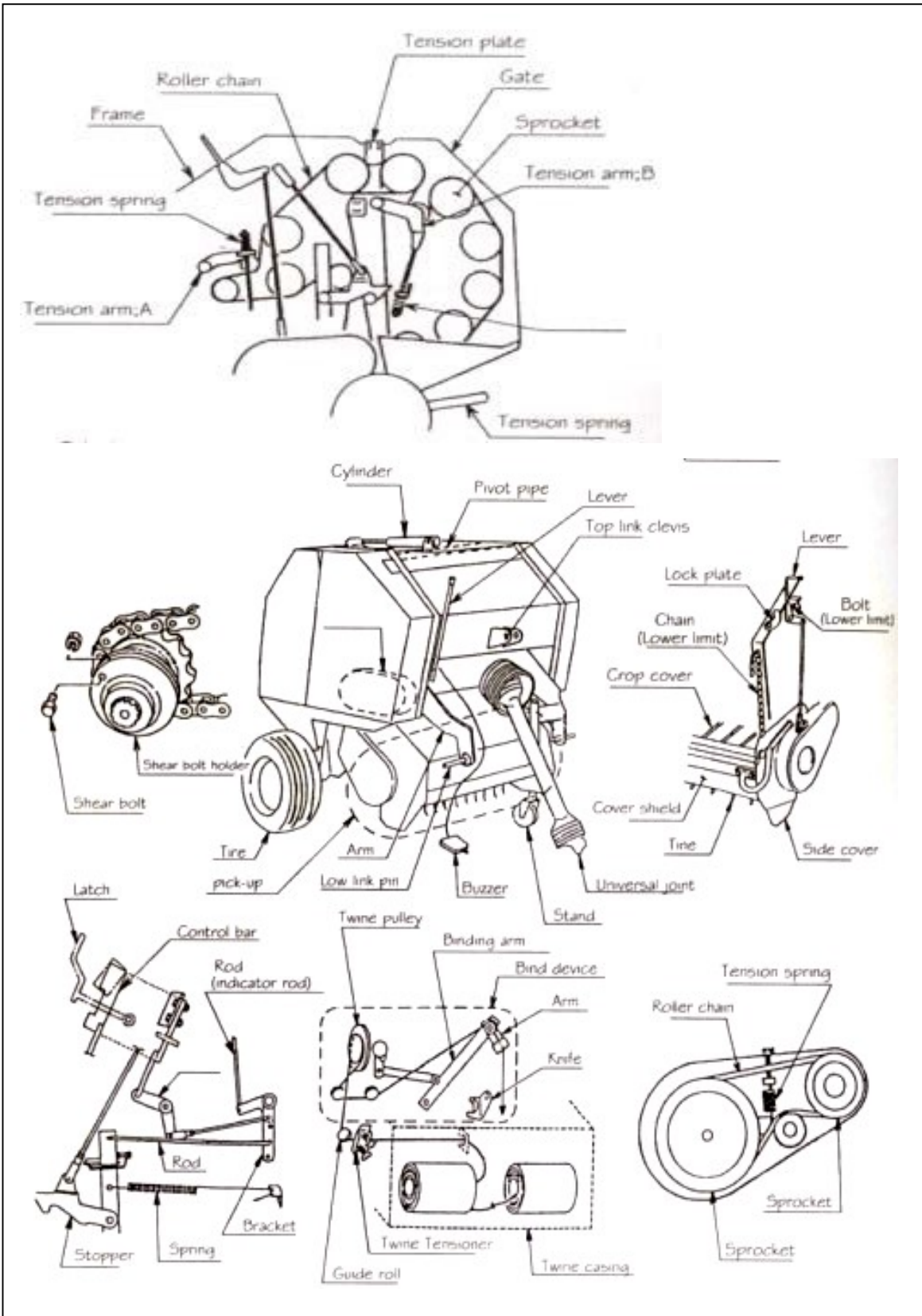

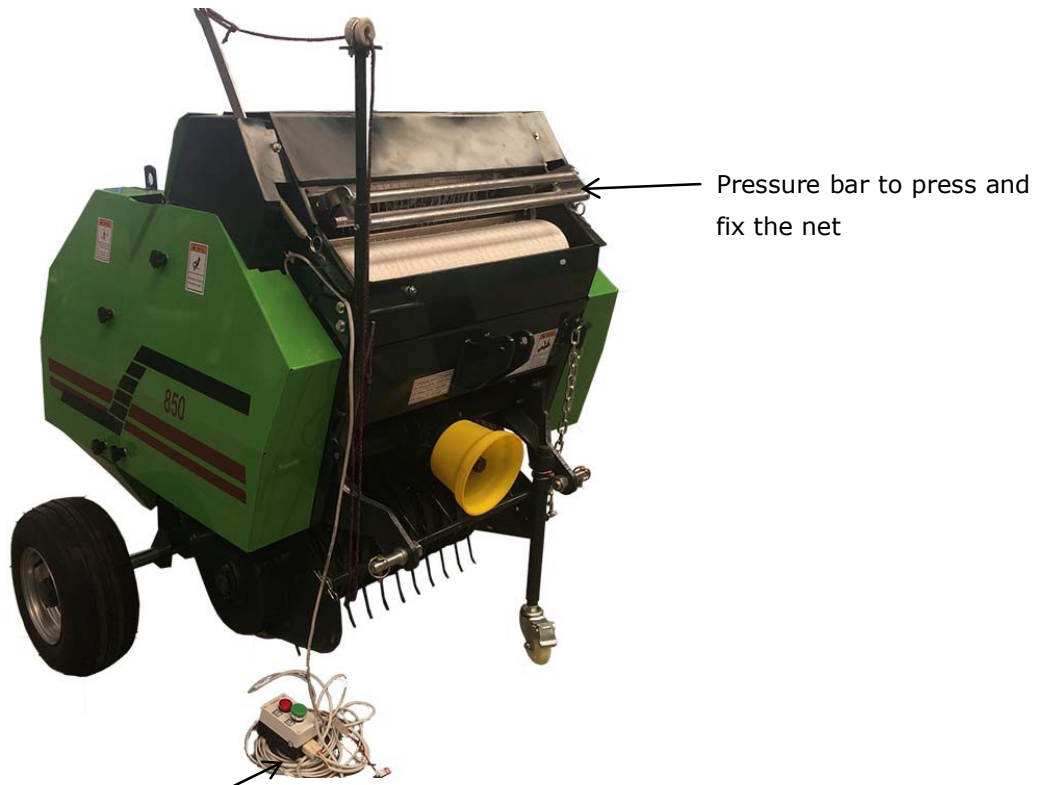

Release the bales



By adjusting the spring in different holes, adjust the tension of the pressure bar; make it press the net always.

1. Lower link pin and upper link

Lower link pin and upper are connected with the tractor lower links and top link.

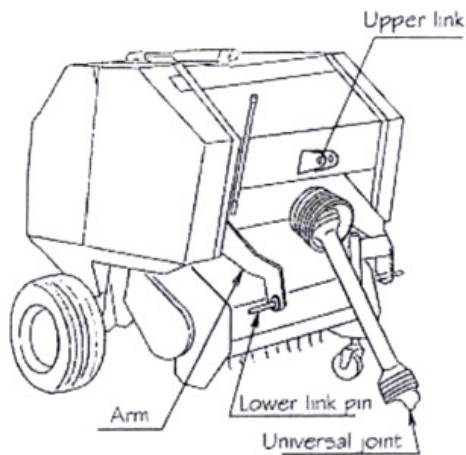

2. Shear bolt

shear bolt is sheared when overload affect to the machine for preventing from the damaged of the machine

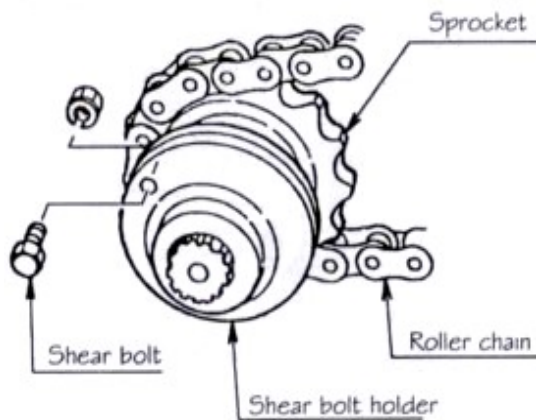

3. Pick up

Pick-up is operated to pick-up baling Material from the ground.

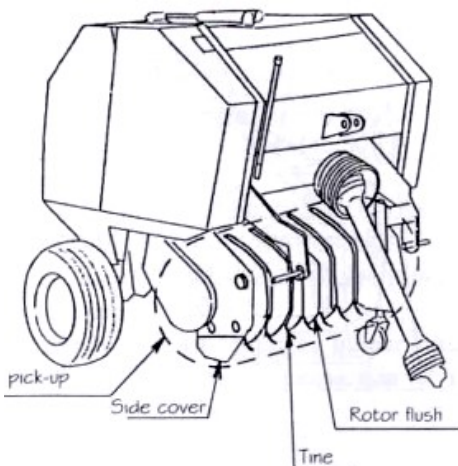

4. Lever and lock plate

pick-up is lifted and is hold by lock plate for transportation of the machine.

Pick-up is lowered by releasing lock plate.

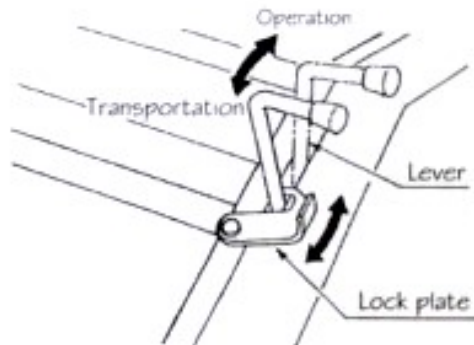

5. Chain and bolt(lower limit)

Chain and bolt limit the height of pick-up tines from the ground.

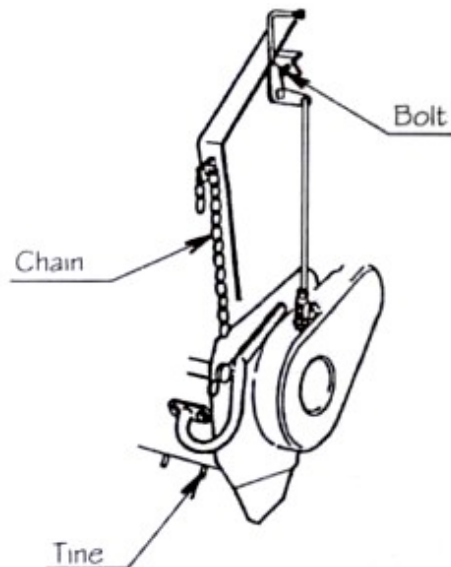

6. Crop cover, Cover shield and side cover

Crop cover helps to convey hay or straw smoothly to the chamber.

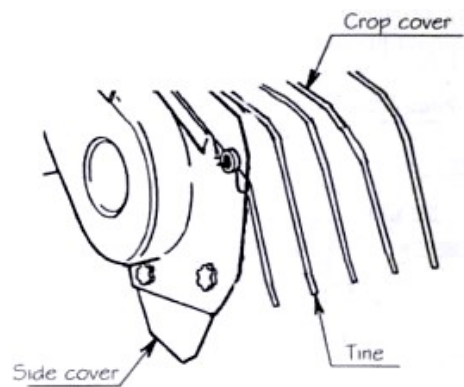

7. Roller chain and sprocket

Roller chain transfer the power to driver pick-up.

Friction clutch slips when over load affects to pick-up for preventing from damaged of pick-up

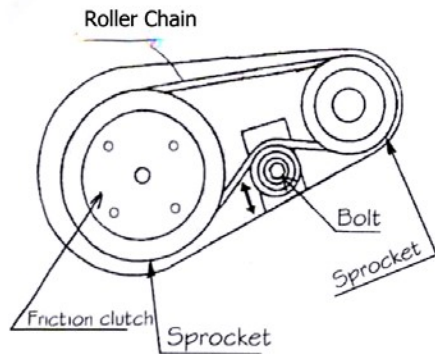

8 Chamber and roll

Chamber is formed by rolls.

rolls rotate themselves and rotate baling material for making cylindrical material inside of chamber.

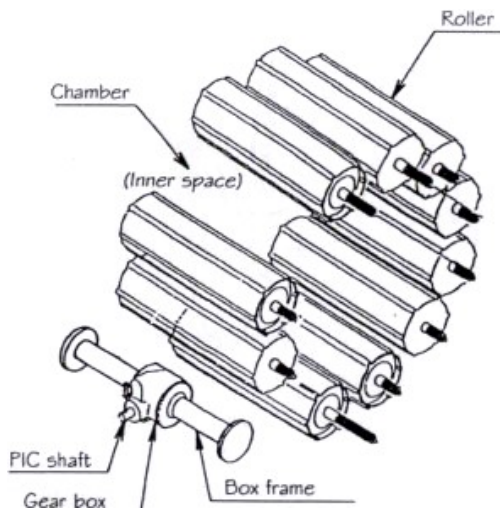

9. Spring (tension spring)

Spring gives proper tension to roller chain.

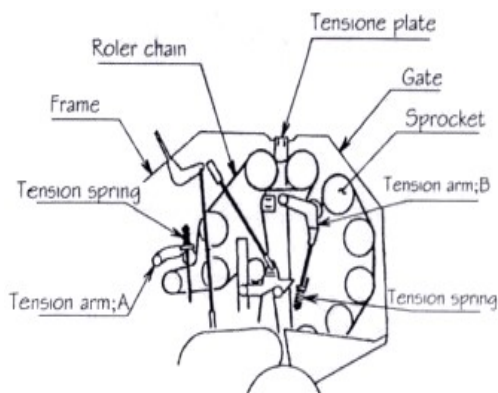

10. Rod and bracket

Bale density can be adjusted by changing the rod position into hole.

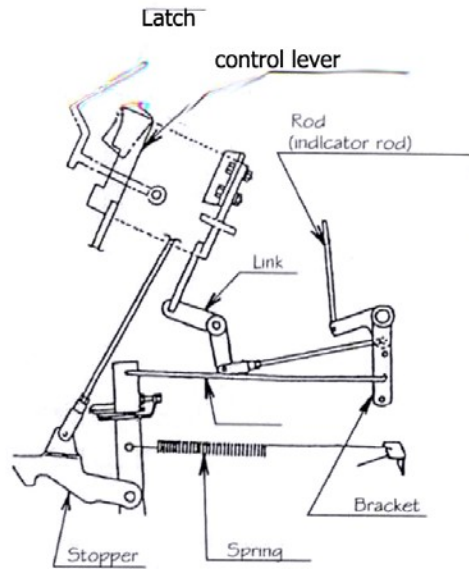

11. Rod (Indicator rod)

Rod shows to the operator the progress of making bale.

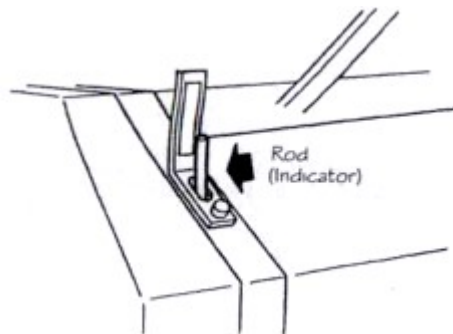

12. Binding device

Binding device winds twine on a finished bale.

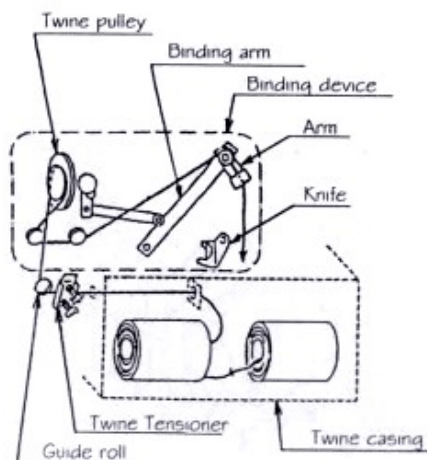

13. Hydraulic power package and lever

Hydraulic power package actuate hydraulic cylinder to open and to close gate for bale ejection.

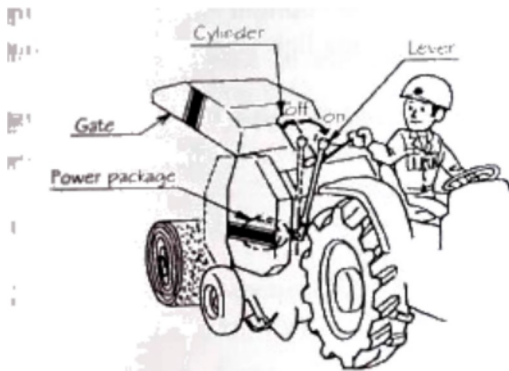

14. Bale ejector

The bale ejector rolls the finished bale far enough from the machine to allow gate close.

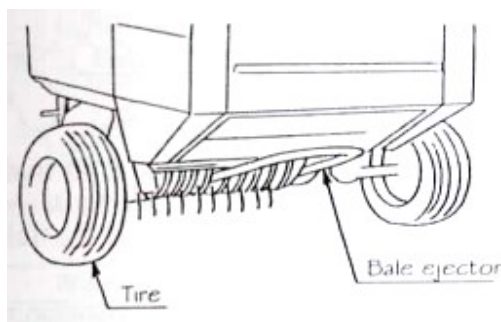

2 Applicable tractor size

This machine is designed to perform by attaching to suitable size of the tractor.

If this machine is attached to unsuitable size of tractor, it will have a possibility of giving bad affection to durability or to operation.

Application tractor HP
 RXYK0850 From 18 HP to 50 HP
 RXYK0870 From 30 HP to 50 HP

Never attach the machine smaller tractor than 18HP(RXYK0850) or 30HP(RXYK0870).

It will be a cause of serious accident lack of weight balance.

If the machine is attached to bigger tractor than 50HP, it will have a possibility to give damage to the machine.

3 Assemble

1. Package opening

Open the package and unite the parts from package wooden frame.

2. Details of attached parts

Make sure if all parts delivered in accordance with packing list.

3. Process of assembling

Refer to the mark numbers on nuts and bolts necessary for assembling in the packing list.

(1) Attach the tires on the machine and fix them by nylon nuts and bolts.

Adjust the tire tread not to trace to the tractor wheel tracks.

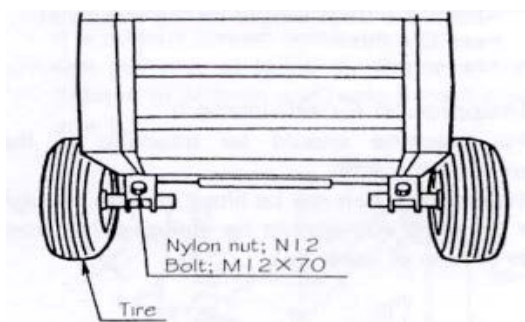

(2) Attach stand to arm;L

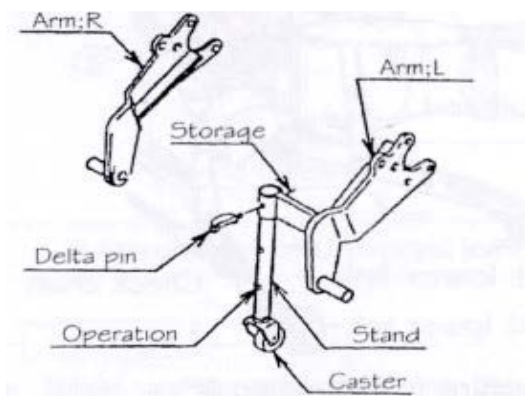

(3) Extend the rod of hydraulic cylinder and align the hole of barrel and the hole of pivot pipe. Then apply bolt.

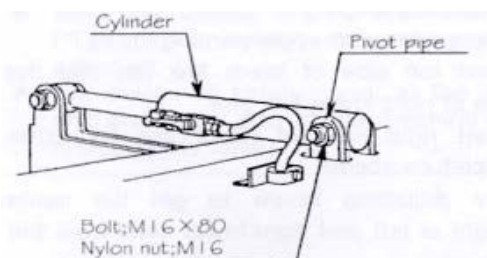

- (4) Refer to parts list to apply other parts to the machine.

4 Attaching to a tractor

• Warning

- Bystanders must keep safely distance when the machine is attached to the tractor or detached from the tractor.

• Caution

- Attach the machine to the tractor or detach the machine from the tractor on flat and solid ground.
- If the machine is attached to a light weight tractor, it has a possibility of getting unstable steering. Attach the front weight on the tractor in case like this.

1. Preparation for attachment

This machine should be attached to the standard 3P tractor.

If the machine can not be lifted up high enough, the pin of lift rod should be inserted into front side of hole of lower link.

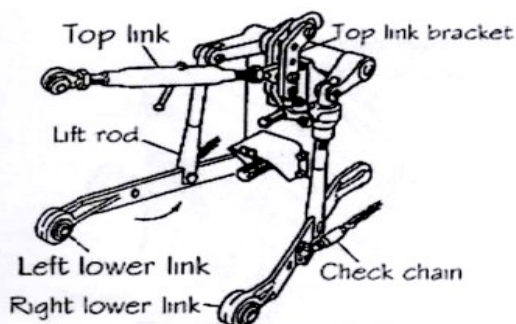

2. Attaching to a standard 3P

In accordance with following procedure.

- (1) Start engine of the tractor and drive a tractor to backward until tips of lower link will be aligned.
Stop engine and apply parking brake.
- (2) Insert left side of lower link pin into the hole of right lower link pint.
Insert right side of lower link by same procedure above
- (3) Turn adjusting screw to get the same height of left and right lower links from the ground.

- (4) If the width of lower link is small, adjust the link of left side (look from backward) internal
- (5) Lift the 3P machine by 3P connection to let the 3P frame upright rise choose the position of main link pin then connect and fix.
- (6) Start engine of the tractor and operate the oil pressure handle to the machine then stop the engine.

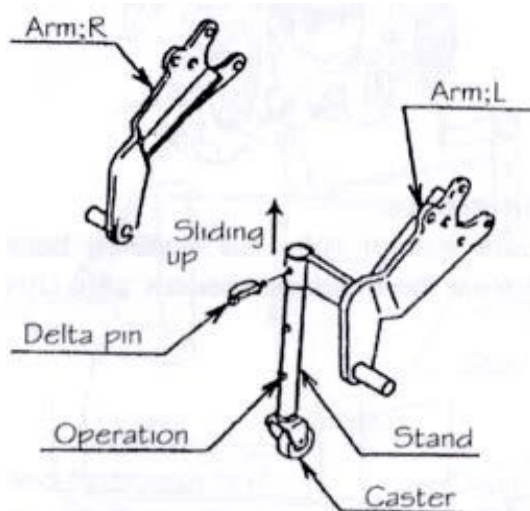

- (7) Align the center of PIC shaft and PTO shaft by check chains and then tighten check chains to protect the machine swing,

3. Attachment of power package operation rope

Caution in operation

- Connect operation rope to the tractor not to touch with universal joint and to have enough slackness not to stretch in turning.

The breaking end of rope is fixed inside of driver's cab(no effect to operation)

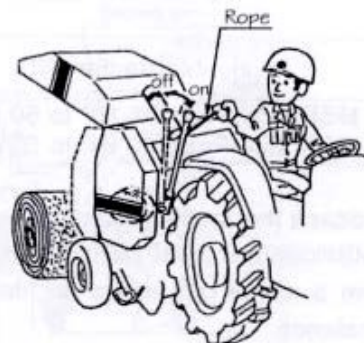

4. Attachment of buzzer

Caution in operation

- Adjust the length of electric cable to get enough slackness and not to stretch in turning.
Tie the surplus of electric cable with a string to the tractor.
Turn off the switch when the machine is not used.

- (1) Attach the buzzer at suitable position for the operation.
- (2) Connect with accessorial electric cable to power of tractor(12V).

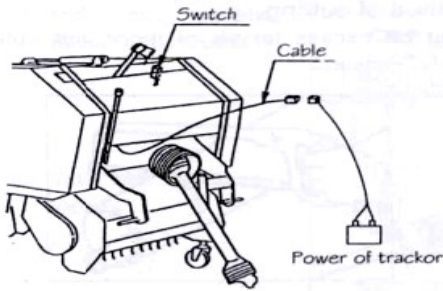

5. Method of twine threading

Warning

- Stop the tractor engine when twine is treaded.

Caution in operation

- Use only original twine.
TG0800 (Jute 8500 feet)
TP0800 (Polypropylene 1100 feet)

- (1) Contain two twine spools in the twine casing.
- (2) Connect the end of rope G.Knot be made as small as possible.

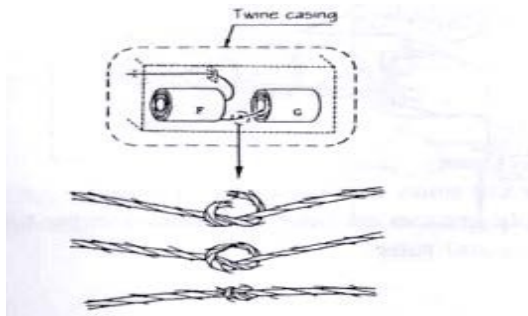

- (3) Turn twine pulley to the direction of arrow until binding arm move from outside to inside and then stop turning at horizontal distance 150mm between tip of binding arm and pivot.

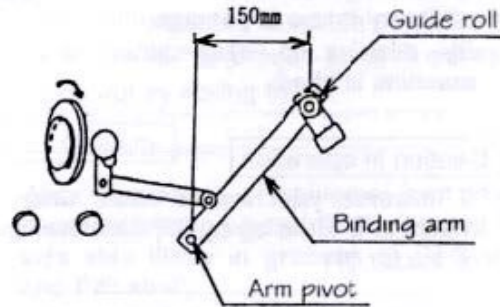

- (4) Thread twine tip order from 1 to 9.

Use attached twine threader places where it is difficult thread twine.

Cut the end of twine by the length from 350mm to 380mm and hang it from binding arm tip.

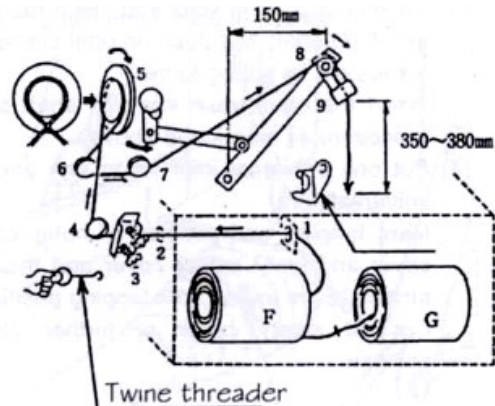

5 Attachment of Universal joint

Danger

- Never use universal joint with damaged safety cover or without safety cover.
- Inspect it if damage is found out on universal joint.
- Stop the tractor engine and disengage PTO clutch when universal joint is attached.
- Fix chains of safety cover to the tractor and stationery part of the machine not to rotate safety cover.

• Caution

- If overlap length between inner and outer tube of universal joint is less than 100mm in extended position, it will be a cause of universal joint breakage.

If the space between inner and outer tube is less than 25mm in retracted position, it will be a cause of damage.

By pushing to each other when the machine is lifted.

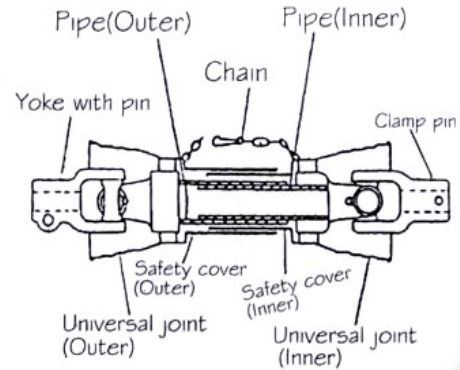

Caution in operation

- If universal joint makes noise when the machine is lifted up by 3P, limit the height of tractor 3P.

1. Universal joint length check

(1) Pull out other tube of universal joint from inner tube of universal joint.

(2) Lift up the machine and stop the lifting at the closet distance PTO shaft and PIC shaft.

(3) Push cramp pin of yoke and insert the yoke into PTO shaft and push on until cramp pin comes out by spring force.

Insert the other yoke into PIC shaft same procedure as mentioned above.

(4) Put one universal joint on to one another universal joint.

Mark lapping end position of outer safety cover and inner safety cover and mark at further 25mm inside from lapping position.

Cut off safety cover at further 25mm position.

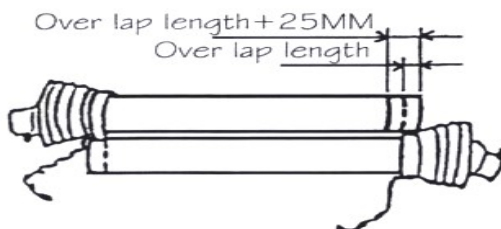

(5) Lift the machine and stop lifting at the most separated position between PTO shaft and PIC shaft.

(6) Put one safety cover on to one another cover.

If lapping length is less than 100mm, replace it to longer universal joint.

2. Method of cutting

(1) Cut off excess length of inner and outer safety cover.

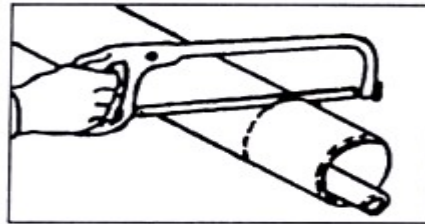

(2) Mark on inner and outer pipe the same length of cut off safety cover from the end of inner and outer tube.

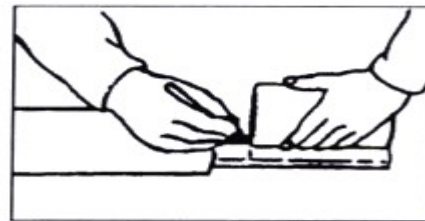

(3) Before cutting off, put rag into between safety cover and pipe not to come into sawdust.

Cut off excess length of tube by metal saw.

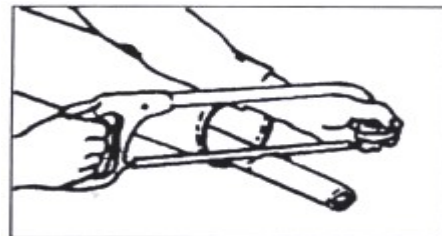

(4) File cut ends and clean the surface.

Apply grease on tube and insert inner tube into outer tube.

3 Method of outer safety cover removal

(1) Disassemble procedure of cover

- ① Take out fix screw



- ② Revolve the cover to the position of release.

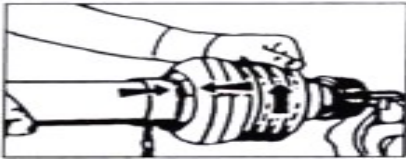

- ③ Pull out safety cover from tube.

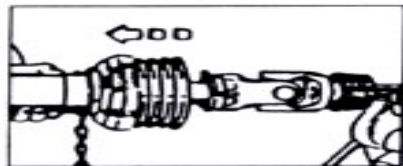

- ④ Take out the slide loop.

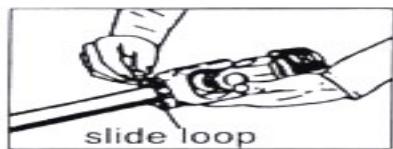

(2) Assemble procedure of cover

- ① Apply oil to slide loop channel and tube inside.



- ② Open the cut mouth of slide loop and limbed it to the channel of tube.



- ③ Fit the safety cover.

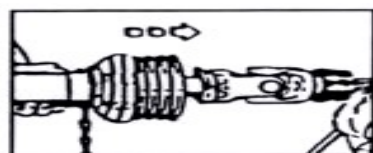

- ④ Screw the cover tightly

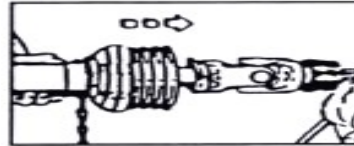

- ⑤ Fix the position with fix screw



4 . Connection of universal joint

(1) Connection to the machine

Push cramp pin of yoke and insert yoke into PIC shaft and push on until cramp pin comes out by spring force.

(2) Connection to the tractor

Push cramp pin of yoke and insert the yoke into PTO shaft and push on until cramp pin comes out by spring force.

Caution:

After connection of universal joint, make sure that cramp pins of PTO side and PIC side stay firmly in grooves of PTO shaft and PIC shaft. If the pins do not stay in grooves firmly, it will be a cause of serious accident.

(3) Fix of safety cover chain

Fix safety cover chain on stationary part of tractor to prevent from rotation of safety cover.

Slacken off chain not to stretch it in the up and down movement of tractor 3P.

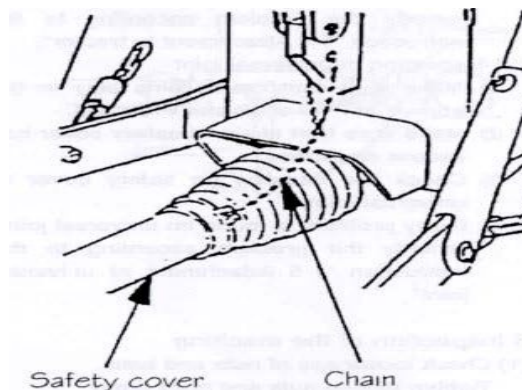

2 Inspection before operation

Following should be done before operation to stand long life the machine

1 Inspection before operation

1. Inspection of the tractor parts

Inspect the tractor parts in accordance with operation manual of the tractor.

2. Inspection of connecting parts

(1) Inspection of 3P connecting parts

1) Make sure that locking pin is inserted into the hole of low link pin.

2) Make sure that locking pin is inserted into a hole of top link pin.

3) Make sure that check chains of the tractor are stretched firmly.

4) If any problem is found in connection, remedy the problem according to the instruction "1-4 Attachment to tractor".

(2) Inspection of universal joint

1) Make sure that cramp pins stay in the groove of PTO shaft and PIC shaft.

2) Make sure that chain of safety cover has excess slackness.

3) Check the damage on safety cover of universal joint.

4) If any problem is found on universal joint, remedy the problem according to the instruction "1-5 Attachment of universal joint".

3 Inspection of the machine

(1) Check looseness of nuts and bolts.

Tighten loosen nuts and bolts firmly.

(2) Check if the shear bolt is sheared or not.

If it is sheared replace to new one referring sufficient. To the parts list.

Beforehand, prepare for replacement shear bolts.

(3) Check if roller chain is properly stretched. Adjust it in accordance with the instruction "5-2-1 Adjustment of roller chain stretch".

(4) Check the length of pick up tension if the length is improper, adjust the length in accordance with the instruction of "5-2-2 Pick-up V-belt

(5) Check the length of twine tensioner.

If the length is improper, adjust it in accordance with the instruction "5-2-3 Adjustment of twine tensioner".

(6) Check the sharpness of binding knife to cut twine.

If it has a problem, solve the it in accordance with the instruction "5-2-5 Adjustment of binding knife".

(7) Check if twine is enough, twine is threaded properly and binding arm is in proper position.

If any problem is found, solve it in accordance with the instruction "1-4-4 Method of twine treading".

(8) Check damage of tine and rotor flush.

If it is damaged, replace it to new one by referring to parts list.

(9) Check stuck hey or straw in the machine. Remove stuck crop from the machine.

(10) Check application of oil and grease. If it is not applied properly lubricate in accordance with the instruction "2-3 Lubrication spots table".

(11) Check if tier air pressure is sufficient. If it is insufficient, apply air until the pressure becomes 195kPa(2.0Kg/m²)

2 Inspection in tractor engine running

1. Inspection of the tractor hydraulic

Lift up the machine by controlling lever of lift up and down for hydraulic control..

If the machine will not come down in lifting up position, hydraulic system has no trouble. If hydraulic system has any trouble, contact with tractor dealer for solving problem.

2. Inspection of machine hydraulic system

(1) Inspection of machine hydraulic system for gate opening and closing

Warning

Bystanders must be away from the machine when gate is opened.

Warning

Bystanders must be away from the machine when gate is opened.

Lock gate by the stop valve when the machine is checked in the gate opening situation.

caution

If the hydraulic hose is damaged or hydraulic fitting is loosen,it will be cause of injuring by leaking high pressured hydraulic oil or suddenly dropping of the machine.

Replace damaged hydraulic hose or fittings and tighten loosen fittings.

- 1) Turn lever of stop valve for gate opening and closing to "Opening"position.

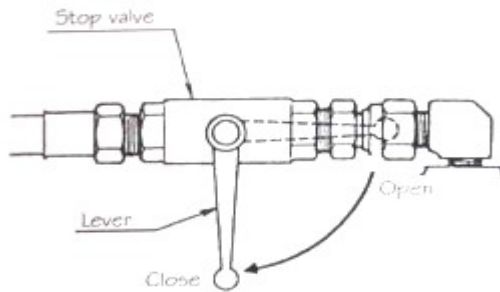

- 2) Start the tractor engine and engage PTO to rotate PTO shaft and then open gate by operating lever of power package.

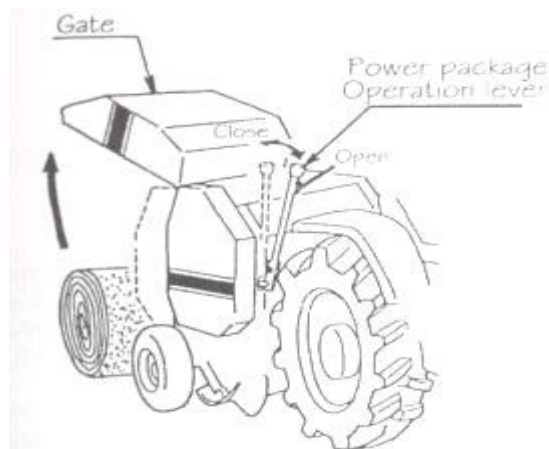

- 3) Turn lever of stop valve to "close"while pulling the lever of the power package at full opened gate position.

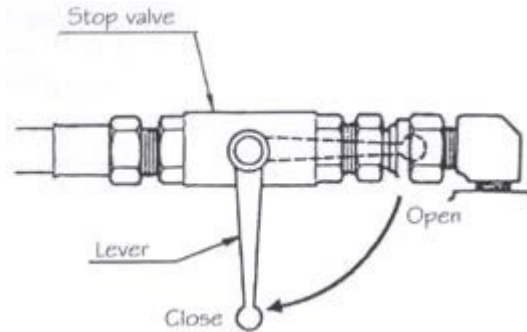

- 4) If the gate does not come down, it has no trouble. If gate comes down, check oil leakage and repair or replace damaged part.

- 5) Close the gate by turning slowly lever of the stop valve to "Open" direction. If the air remains in the hose or cylinder, loosen male adapter and let the air out it.Tighten swivel adaptor after releasing air.

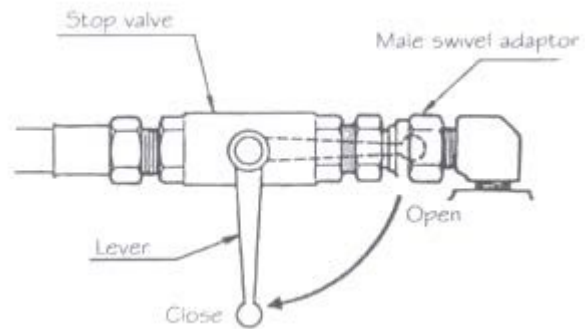

3 Lubrication spots table

- Apply fresh and clean oil and grease the machine.

- Apply grease to a grease nipple until old grease come out.

1) Gear box

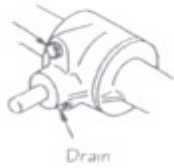

2) Worm gearbox

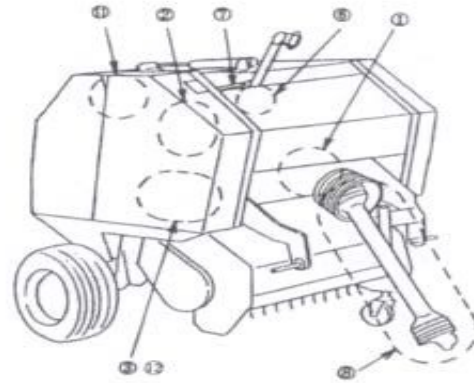
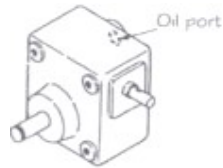

3) Power package

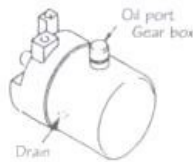

4) Housing

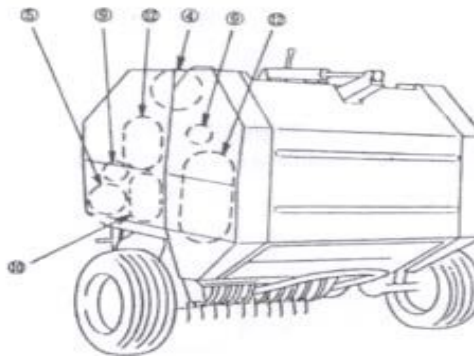

5) Sprocket



6) Arm support



9) Tension arm pivot



10) Link pivot



7) Crank bar



8) Universal joint

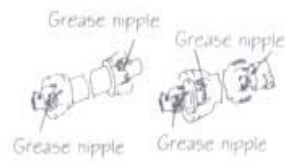

11) Gate pivot



12) Roller chain



No.	Lubrication points	Point	Kind of lubrication	Changing time	Q'ty	Remarks
1	Gearbox	1	Gear oil ; SAE 90 API GL-5	After 100 hr or one season	500g	Discharge gearbox, cleanin g before oiling
2	Worm gearbox		Gear oil ; SAE 90 API GL-5;			
3	Power package	1	Gear oil ; SAE 90 API GL-5;	Every 100 hr	1.7L	Gearbox tank
4	Housing	2	Grease ; Number3	After operation	Proper Q'ty	Grease nipple
5	Sprocket	1	Grease ; Number3	After operation	Proper Q'ty	Grease nipple
6	Arm support	1	Grease ; Number3	After operation	Proper Q'ty	Grease nipple
7	Crank bar	2	Grease ; Number3	After operation	Proper Q'ty	Grease nipple
8	Universal joint	-	Grease ; Number3	After operation	Proper Q'ty	Grease nipple
9	Tension arm pivot	2	Oiling	After operation	Proper Q'ty	Grease nipple
10	Link pivot	4	Oiling	After operation	Proper Q'ty	
11	Gate pivot	2	Oiling	After operation	Proper Q'ty	
12	Roller chain	4	Grease application	After operation	Proper Q'ty	

3 Operation method

1 Purpose of this machine

1. This machine is produced for baling grass, rice straw and straw. Never use except this purpose.
 - (1) Bale for the hay which is less than 20% of moisture content.
 - (2) Bale the grass for making wrapping silage which is between 50% and 60% of moisture content.
2. Do not operate the machine after stopping rain of in muddy field. Operate the machine in well dried field.

2 Adjustment for operation

1. Adjustment of pick-up tine the height from the ground
 - (1) Adjust pick-up tine height from the ground by limit chain and lower bolt.

Fine adjustment is done by top link pin of a tractor.

Baling material	H
Cut straw	0 mm
Long straw or hay	20mm

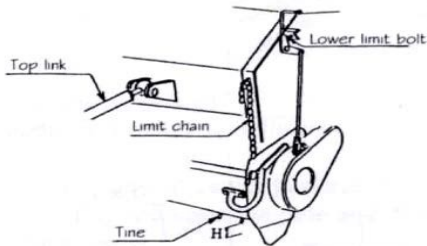

- (2) Select operation position and transport Position by moving the lever and lock plate.

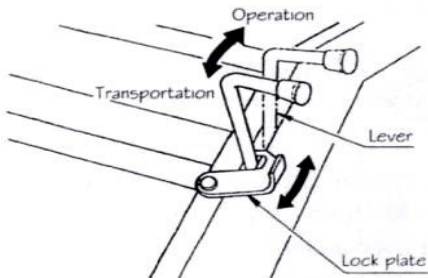

2 Adjustment of twine winding number

Adjust the twine winding number according to baling condition and handling condition of bale.

Winding number	Crop	Handling	Twine pulley
10	Cut straw Dried straw ↓	Many ↓ ↑	Big dia. Pulley
8	↑ Hay Long straw	Few	Small dia. pulley

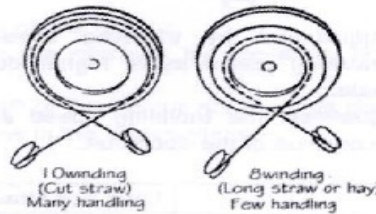

The winding number should be changed according to thickness of twine.

If the twine is thicker, the winding number must be more. Above table is the standard.

3. Adjustment of Cover shield and Side cover

Crop	Cover shield/ side cover
Cut straw	Attachment
Hay, Long straw	Removal

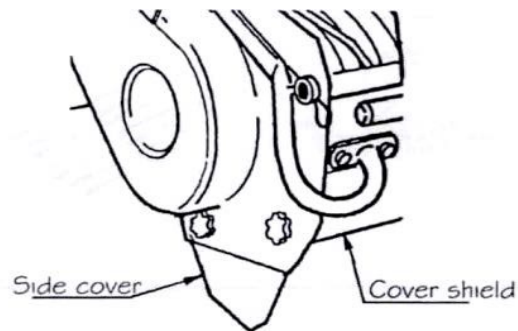

4. Adjustment of the bale density

- Caution**

 - High density of bale requires high tractor PTO horse power. Adjust bale density according to the tractor size, the field condition and the baling material.

(1) Adjustment of the rod

When the rod is inserted into higher position of bracket hole, lower density of bales are made.

When the rod is inserted into lower position of bracket hole, higher density of bales are made.

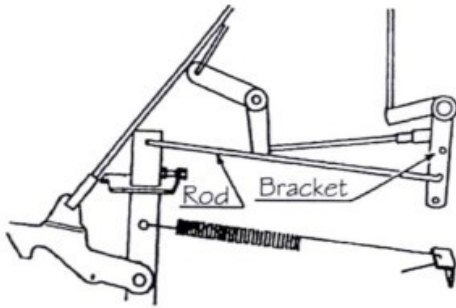

(2) Adjustment by traveling speed lower

traveling speed make higher density of bale.

Adjustment the traveling speed according to condition of the operation.

3 Operation method in field

1. Method of windrow making

Make windrow of the width from 70 cm to 80cm and the height from 30cm to 40 cm as

Uniformly as possible.

The windrows which are made for efficiency and smooth operation are recommended.

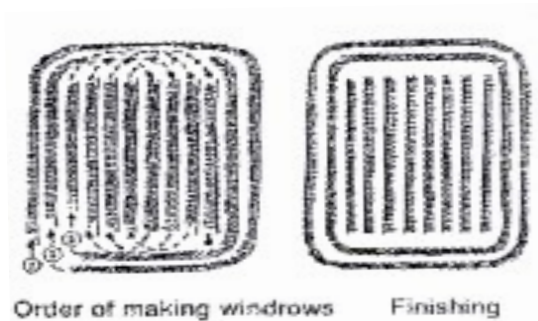

Hay Make windrows as Below	Long rice straw (straw) Straw chop off operation By 3/4 rows rice combine harvester	Operation by dropper of 2 rows rice combine harvester 2 rows direct drop	Cut straw Direct straw pick up is Possible
		Operation by dropper	Operation after making is better than above.

1. Field operation

- Warning
- Bystanders must be away from the machine when pick-up is running. Stop the tractor engine when taking away Stuck baling material from the pick-up.
- Never touch rotating rollers.

Stop the engine of the tractor when taking away stuck grass between rollers.

(1) Put on the switch of the buzzer and rotate PTO and then travel the machine by striding over a windrow.

Adjust PTO speed depending on baling material condition and the moisture content of it.

Baling material condition *	PTO speed
Moisture content	
Standard	540 rpm
Dried* short	350-450 rpm
Moist* stuck pick-up	540-600 rpm

Normal operation speed is 3-5 km/hr.

Adjust the operation speed depending round on the field condition.

Caution in operation

- Do not stop PTO while twine is binding round on a bale

(2) Quantity of the baling material inside of the chamber can know from the indicator.

The indicator rod rise up when a bale coming to complete.

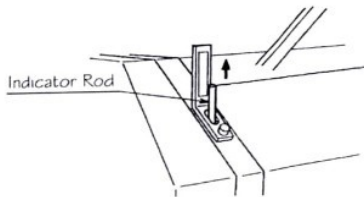

(3) When a bale reaches to complete, buzzer sounds and twine binds on a bale automatically.

Caution in operation

- If the twine binding will not start, forward about 1m.

(4) When twine binding is finished, twine is cut and binding stops.

Pull the rope of power package while PTO is running and open the gate and then eject a bale.

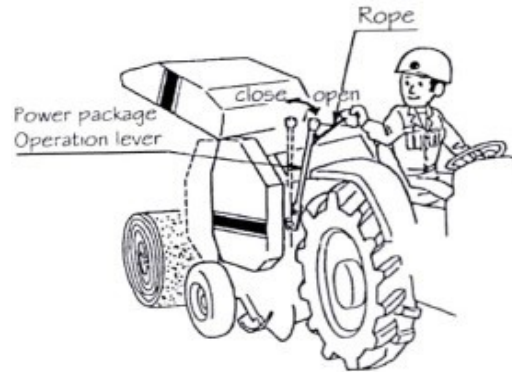

• warning

- Bystanders must be away from the machine when the gate is opened.
- Do not eject a bale at inclined field. Eject a bale always level field.

(5) Return lever of power package after bale ejection to close gate and then start the operation.

4 transportation

1. Stop PTO of the tractor
2. Pull down the lever and lock it by lock plate.
3. Switch off the buzzer.
4. Lift up the machine by operating 3P lifting lever.
5. Lock 3P of the tractor not to come down the machine in the transportation.

4 Out of season for storage

Maintain the machine for keeping long life.

Caution

- Never try to remove blocked material when the machine is running. Disengage clutch of PTO drive, stop tractor engine and make sure all moveable parts stop.

1 Maintenance after operation

field.

1. Remove piled dust from the binding unit.
2. Remove baling material stuck material on the rolls.
3. Remove dust from driving device in the side of the machine.
4. Replace damaged or worn parts to new ones.
5. Inspect driving and connection parts in accordance with inspection spots table.
6. Lubricate in accordance with lubrication spots table.
7. Apply grease on PTO shaft, PIC shaft, power joint and other parts which are not painted to prevent from the rust.
8. When machine and tractor separate, column should be set down.
9. After machine and tractor separate, universal joint should be detached.

2 Detaching from tractor

1. Slid down stand and insert pin into the highest position of a hole.
2. Lower hydraulic control lever of a tractor until tires of the machine contact with the ground.
3. Stop the tractor engine and apply parking brake.
4. Detach power joint from the tractor PTO shaft.
5. Detach right side of lower link, left side of lower link and top link.

3 Storage in out of season

1. Clean every parts of the machine.
2. Inspect moving parts and connecting parts in accordance with inspection and maintenance points table.

If any damaged or worn parts are found, they must be replaced with new ones.

3. Apply grease or oil in accordance with lubrication points table.

Apply oil to rotating, pivoting parts and sliding parts such as clump pin of power joint.

Apply grease on PTO shaft, PIC shaft and spine holes of power joint yoke.

4. Paint or apply oil on damaged surface of parts to prevent from the rust.
5. Store the machine in well ventilating indoor.
6. If there is no choice but to keep the machine in out door, cove the machine with a plastic sheet.

5 Inspection and maintenance

Inspection and maintenance should be done regularly to obtain good condition.

Inspect and maintain each pads In accordance with inspection and maintenance table to

Prevent from accident by poor maintenance.

Since tines, shear bolts, knives and twine are consuming pads, replace worn parts with new ones or replenish with new ones.

• Warning

- Stop the tractor engine and disengage PTO when adjustment of twine binding device is done.
- Lock stop valve for fixing gate when inspection or adjustment is done at opening gate.

Caution

- Lock the hydraulic circuit of tractor when the machine is lifted up for maintenance or for inspection prevent from machine' S failing down.
- Inspection or maintenance should be done On solid g round or concrete. Never inspect or maintain on slant. uneven, or soft ground.
- Stop the tractor engine and make sure all machine parts stop when inspection or adjustment is done.

Hours	Items for checking	Remedy
After initial 1 hour operation	Looseness of all nuts and bolts Slackness of roller chains	Tightening Adjustment in accordance with "5-2-1 Tension adjustment of roller chain"
Before operation After operation (or before operation)	Cleaning up Wear of pick up tines Wear of binding knife Shear of shear bolt Twine consumption Running out of battery cell for buzzer Tires air pressure Looseness and loss of nuts, bolts and pins Abnormal noise or vibration in driving Breakage of power safety cover of roller chain cover Lubrication to rotating and moving parts Adjustment of each parts	Replacement Replacement Replacement / Replenishment Replenishment Replacement (Layer • built cell battery 9V; 6F22) 1 95kPa(2. 0kg / cm2) Tightening and replenishment Remedy in accordance with trouble shooting table 6-1 Replacement Lubrication in accordance 2—3 Lubrication points table Adjustment in accordance 5-2 adjustment of each pads
Out of season	Broken parts Worn parts Cleaning up each parts Damage of painting Worn pivoting pads or pins	Repair Replacement with new one Painting or applying oil Replacement to new ones

transmitting the power smoothly.
 Since the roller chain is especially elongated by initial usage, adjust tension after initial usage.

(1) Adjustment of tension spring

Adjust tension of roller chain on frame on the frame and on gate by adjusting the length of the tension springs.

The length of spring is mentioned below.

The length of the spring is printed in the which is stuck on the machine.

H1=36mm

H2=38mm

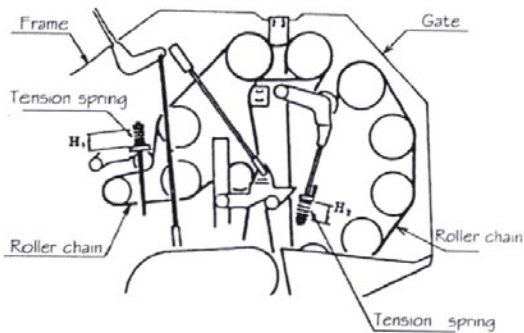

(2) Adjustment of tension plate

Adjust tension of roller chain between frame and gate by tension plate.

Proper roller chain tension gives 3mm deflection when roller chain is pushed by a finger.

Proper roller chain tension gives 3mm deflection when roller chain is pushed by a finger.

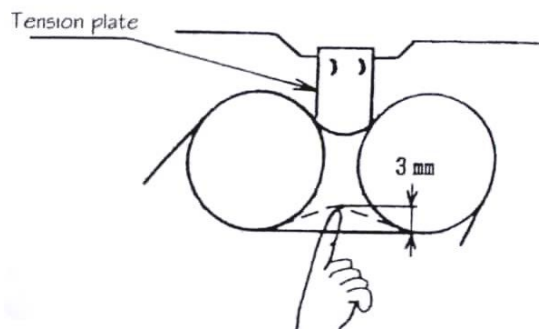

(3) Adjustment of power package

Tension for roller chain to drive the power package is adjusted by moving position of the power package.

Push middle part of chain between both

sprockets by finger.

Correct tension is approx. 5mm of deflection when the chain is pushed.

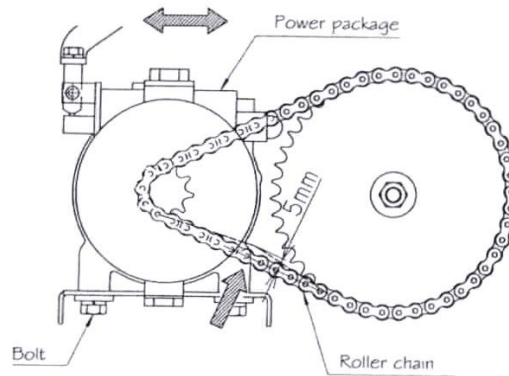

2. Adjustment of drive part for pick. up

(1) Loose bolt, revolve tension r0 1 to adjust chain, after adjustment, fasten the bolt. The most suitable tension is 3mm pressed down at the center of the chain.

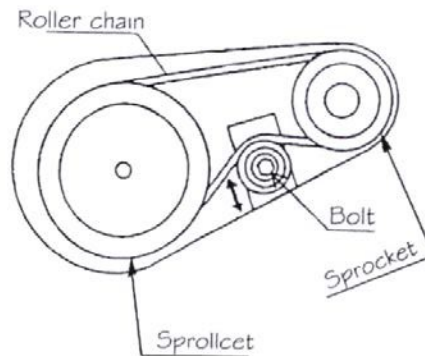

(2) Adjustment of sliding clutch

Springs(4) are adjusted to 27mm

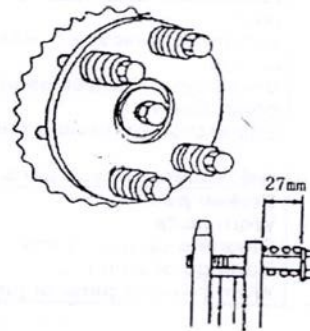

3. Adjustment of twine tension

Adjust spring length to 35mm

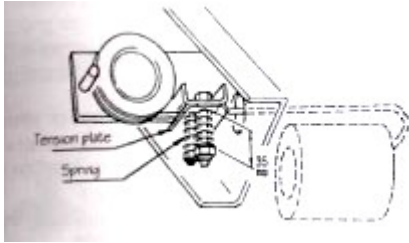

4. Adjustment of arm tension spring

Adjust length of the spring at 8mm

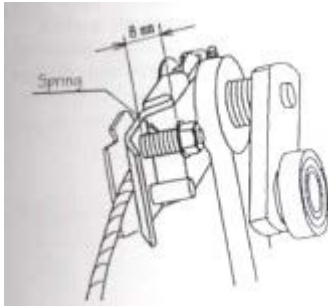

5. Adjustment of binding knife

Remove the knife and attach it after reversing if the knife is dull.

Replace the knife to new one if reversed knife is dull.

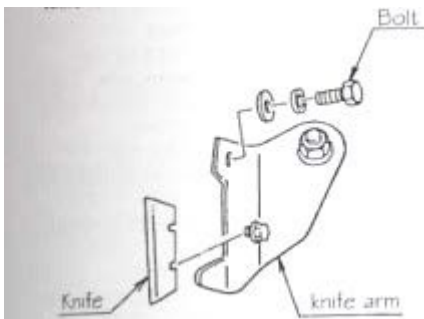

Caution

Apply original replacement knife of the machine

6. Adjustment of the bale density detection link

(1) Adjust the clearance between stopper and collar on gate by bolt.

$L_1=1-2\text{mm}$ is proper.

(2) Remove the fork end on from lower end of release rod and then pull the release rod to lower

Adjust the dimension between lower side of fork end slot and the hole of stopper as mentioned below in above situation.

$L_2=2\text{mm}$ is proper.

(3) Adjust the dimension between latch and cutout of control bar as below.

$L_3=8\text{mm}$ is proper.

Adjust this dimension to $L_3=6\text{mm}$.

If bale weight is too heavy (More than 25kg) because of too much moisture content.

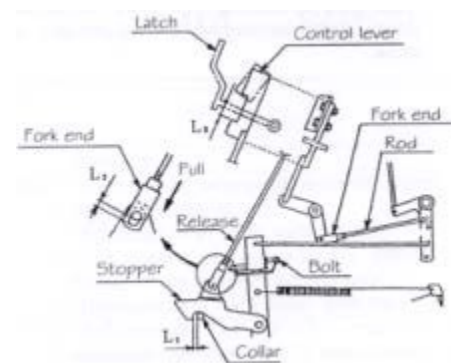

7. Adjustment of Pick-up suspension

Proper suspension springs length on both sides of pick-up is $L=48\text{mm}$.

Adjust spring length according to field condition if the pick-up does not follow well the field unevenness.

Both springs length should be the same after the adjustment.

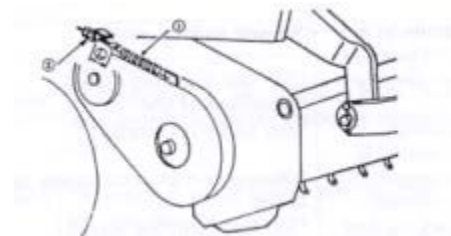

8. Adjustment for closing speed of gate

Closing speed can be adjusted by turning of knob on the slow return valve.

Speed is decreased by turning it to right or is increased by turning it to left.

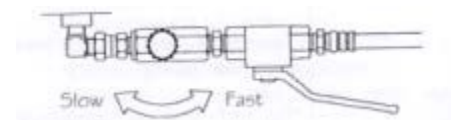

6 trouble shooting

Adjust the machine in accordance with trouble shooting table if it does not work well.

warning

- * stop the tractor engine and disengage PTO when adjustment is done.
- * lock gate by closing stop valve not to fall down when inspection or adjustment is done

1 trouble shooting table

* Pick up

Caution

- * lock the hydraulic circuit of tractor when the machine is lifted up for maintenance or inspection to prevent from machine's falling down
- * Inspection or maintenance should be done on solid ground or concrete.
Never inspect or maintain on slant, uneven, or soft ground.
- * Stop the tractor engine, disengage PTO and make sure all moving parts stop when inspection or adjustment is done.
Ask to the dealer by informing followings if the cause of trouble and trouble shooting is not clear.

Fault	Possible cause	Remedy
* Abnormal noise is made	<ul style="list-style-type: none"> * Breakage of tine * Breakage of rotor flush * Winding of hay or twine * Breakage of cam roller bearing * Insufficient V belt tension 	<ul style="list-style-type: none"> * Tine replacement * Rotor flush replacement * Remove of winding material * Replacement of cam roller bearing * Adjustment in accordance with 5-2-2
* Material is not picked up cleanly	<ul style="list-style-type: none"> * Wrong pick-up setting * Too fast traveling speed * Breakage of tine 	<ul style="list-style-type: none"> * Adjustment in accordance with 3-2-1 * Reduction of traveling speed * Making windrow in accordance with 3-3-2 * Shortening top link for obtaining forward declined machine position
* Baling material is clogged between pick-up and chamber.	<ul style="list-style-type: none"> * Too fast PTO rotation * Obstruction by side cover and cover shield * Too fast traveling speed * Too wide and too high windrow * Too much declined pick-up 	<ul style="list-style-type: none"> * Adjustment in accordance with 5-2-2 * Replacement of broken V belt with new one * Adjustment in accordance with 3-2-1 * Making windrow in accordance with 3-2-2 * Adjustment of cutting height for a mower * Taking out side cover and shield cover
* Pick-up does not rotate	<ul style="list-style-type: none"> * Wrong V belt tension adjustment * Breakage of V belt * Too much clearance between pick-up tines and ground * Too wide and too high windrow * Too much mowing height from ground * Obstruction by side cover and shield cover 	<ul style="list-style-type: none"> * Adjustment in accordance with 5-2-2 * Replacement of broken V belt with new one * Adjustment in accordance with 3-2-1 * Making windrow in accordance with 3-2-2 * Adjustment of cutting height for a mower * Taking out side cover and shield cover

Pick-up

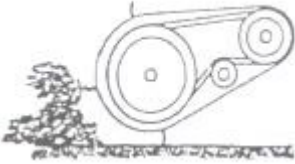
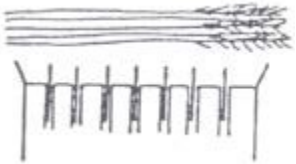
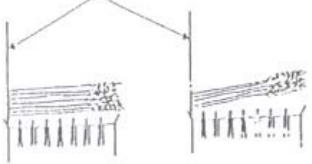
Fault	Possible cause	Remedy
<p>* pick-up pushes long stem rice straw to forward</p> 	<p>*Matching of pick-up center and rice straw center in the pick-up operation.</p> 	<p>* Picking-up by right side or pick-up.</p> <p>(Turn up root of straw)</p> 

* Roller

Fault	Possible cause	Remedy
<p>* Roller makes abnormal noise</p>	<p>* Wrapping material or mud on roller or clogging material</p> <p>* Insufficient lubrication</p> <p>* Insufficient roller chain tension</p> <p>* Dent in roller</p>	<p>* Remove of wrapping material. mud or clogged material</p> <p>* Application Of oil to roller chain</p> <p>* Adjustment in accordance with 5-2-1</p> <p>* Replacement dent roller with new one</p>
<p>* Material is winding On roller</p>	<p>* Too fast PTO rotation</p> <p>* Material clogging in pick up</p> <p>* Dent in roller</p>	<p>* Adjustment of PTO rotation in accordance with 3-3-2</p> <p>* Remedy in accordance with "pick-up" trouble shooting</p> <p>* Replacement dent roller with new one</p>
<p>*Heat generate in Roller chain</p>	<p>*Too high bale density</p> <p>*Insufficient lubrication to roller chain</p> <p>*Insufficient roller</p>	<p>*Adjustment; n accordance with 3-2-4 and 5-2-6</p> <p>*Application grease to roller chain</p> <p>5-2-1</p>

* Buzzer

Fault	Possible cause	Remedy
<p>* Buzzer does not sound</p>	<p>* Switch off</p> <p>* Running out of battery cell</p> <p>* Wrong cable connection</p> <p>* Too much distance between switch lever and binding arm</p>	<p>* switch on</p> <p>* Replacement of battery cell</p> <p>* Correction of cable connection</p> <p>* Replacing broken cable with new one</p> <p>* Adjustment of switch location</p>

*** Binding**

Fault	Possible cause	Remedy
*Binding does not work when bale is finished	<ul style="list-style-type: none"> * Binding is not set in correct initial position * Insufficient lubrication * Wrong adjustment of tensioner * Twine is coming off from twine pulley * Twine is tangled or caught * Lower density in bale left side * Binding arm does not rise up after coming off latch. * Twine tip does not come in chamber 	<ul style="list-style-type: none"> * Adjustment in according with 1-4-5. * Lubrication * Adjustment in accordance with 5-2-3. * Adjustment in accordance with 1-4-4. * remove tangle and catch of twine * Supply of larger quantity of material to left side of the machine * Lubrication and adjustment of falling speed by double nuts. * Adjust falling down speed of twine arm not to be ahead of twine falling * Remove obstruction and let twine tip into chamber.
* Binding device work before reaching to setting density	<ul style="list-style-type: none"> * Binding is not set in correct initial position * Longer leading twine length because of dull knife 	<ul style="list-style-type: none"> * Adjustment in accordance with 1-2-4. * Replacement of knife and adjustment of leading twine length in accordance with 1-4-4.
<ul style="list-style-type: none"> * Twine comes off from bale * Twine is not cut smoothly 	<ul style="list-style-type: none"> * Fewer twine binding number * Twine tension is too loose 	<ul style="list-style-type: none"> * Adjustment in accordance with 3-2-2 * Tighten nylon nuts of twine tension plate one or two turns

*** Gate**

Fault	Possible cause	Remedy
* Bale does not come out	<ul style="list-style-type: none"> * Density too high density * Too wide windrow * Declined field 	<ul style="list-style-type: none"> * Adjustment in accordance with 3-2-4 * Making windrow in accordance with 3-3-1 * Ejection of a bale in flat place
* Gate does not open	<ul style="list-style-type: none"> * Closing of stop valve * Leakage or breakage of hydraulic circuit * Wrong adjustment of locking hook * Disengagement of PTO * Insufficient of power package oil 	<ul style="list-style-type: none"> * Opening of stop valve * Remedy in accordance with 2-2-2-1 * Adjustment in accordance with 5-2-6 * Engage PTO and eject bale while PTO is running. * Application of Oil in accordance with 2-3.

*** Shear bolt**

Fault	Possible cause	Remedy
* Shear bolt is cut	<ul style="list-style-type: none"> * Too high PTO speed * Clogging material in Pick-up * Winding material on pick-up * Looseness of shear bolt 	<ul style="list-style-type: none"> * Operation in normal PTO speed * Remedy in accordance with " pick-up" clause of trouble shooting * Remedy in accordance with clause 3-3-1

*** Universal Joint**

Fault	Possible cause	Remedy
* Abnormal noise is made	<ul style="list-style-type: none"> * Insufficient Lubrication * Too much sharp angle of universal joint 	<ul style="list-style-type: none"> * Application grease to sliding pipes, spiders and mounting part of safety cover * Adjustment of tractor top link length, lower link stabilizer and lower link upper limit.

*** Bale density detection link**

Fault	Possible cause	Remedy
* Gate opens because of stopper's corning off from gate	* Stretching of power package operation rope	<ul style="list-style-type: none"> * Adjustment in accordance with 1-4-3 * Attachment of power package operation rope
* Bale density is loose	<ul style="list-style-type: none"> * Exceeding bale density operation because of not sounding buzzer * Wrong dimension adjustment of bale density detection link 	<ul style="list-style-type: none"> * Remedy in accordance with "Buzzer" in trouble shooting * Adjustment in accordance with 5-2-6 * Application of bale density detection link

If you do not see the cause of a trouble or how to repair it, notify the following items to the supplier of the machine.

1. The name of machine
2. Model
3. Serial number
4. Details of trouble(explain fully)